



OFFICIAL WEBSITE

PRODUCT SELECTION

INDUSTRIAL GAS DETECTION

V21.01.02

Nanjing AIYI Technologies Co., Ltd.

Address: Building 13, No. 1318 Qingshuiting East Road, Jiangning District,
Nanjing 210000, China

Tel: +86 25 87756351

Fax: +86 25 87787362

Website: www.aiyitec.com www.autequ.com

E-mail: sales@autequ.com

Disclaimer: All images in this album, configuration, technical parameters for the selection of reference,
the specific configuration and parameters are subject to the factory technical documents.

Nanjing AIYI Technologies Co., Ltd.



INTRODUCTION

Nanjing AIYI Technologies Co., Ltd. is a Natural high-tech company that combines the R&D, production and sales of optic-mechanical-electric products. We are dedicated to providing complete gas & dust safety solutions to clients.

AIYI Technologies is located in Nanjing, a technologically advanced city. And we have been adhering to the motto of “*Innovative and Dedicated*” with our special focus in safety solutions. AIYI Technologies insists independent R&D and production, Our featured products are portable and fixed gas detector, online gas analyzer, dust monitor.

With advanced production equipment and strong technical force, AIYI Technologies has accumulated more than 40 intellectual property rights. The product quality and professional service of AIYI Technologies have been highly regarded among worldwide clients, and we have already been the leading in China safety industry.

Our Vision: Focusing on serving customers and achieving strivers.

Our Mission: Make the environment more eco-friendly and safer.



HONOR & QUALIFICATION

As an ISO certified manufacturer, AIYI Technology is a strict follower of all relevant international standards for the high quality and reliable products. It has successively obtained the ISO:9001-2015 certificate, ATEX & SIL2 Certificate which issued in Italy, the certificate of China Compulsion Certification (CCC Certification), and the national permit for producing measurement instruments(CMC, CPA), conformity certificate of explosion-proof by supervision & test center of Ex-products of China petroleum & chemical industry.



RESEARCH & DEVELOPMENT



AIYI Technologies insists independent R&D and production, keeps introducing advanced domestic and foreign technologies and improving the core competitiveness of the company. AIYI Technology is in possession of more than 40 patents of various kinds.

At present, the R&D center has more than 40% of the master's degree. And the company has many laboratories such as chemistry, electronics, and the environment. We will continue to Explore and make the greatest contribution to the development of the automation field.



PRODUCTION EQUIPMENT

As a modern manufacturer of safety instruments, AIYI Technologies is equipped with various production and processing devices for assembly, testing, aging, inspection, and packaging.

AIYI Technologies has built up a complete quality control system and it strictly follows the requirements of ISO:9001-2015. The company is equipped with temperature & humidity chamber, gas compounding & concentration chamber, electronic thermometer, grounding resistor sensor, sound meter etc., making sure that every single product meets the demand of customers.

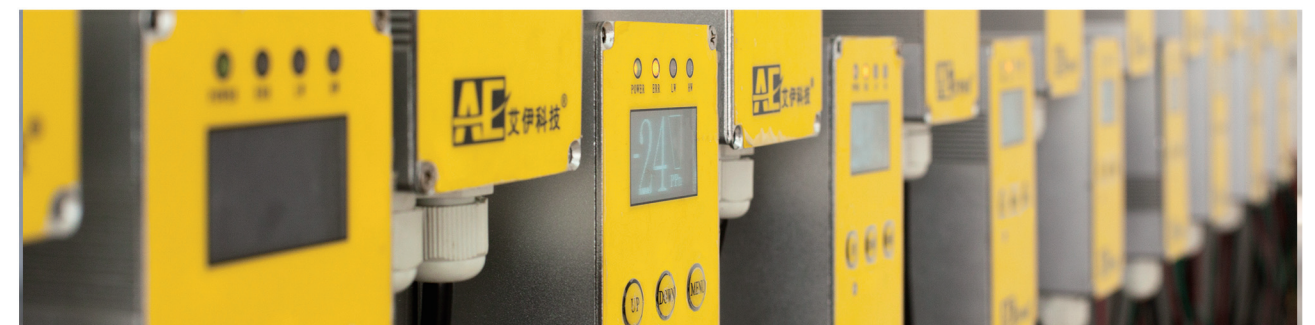

OUR CLIENTS

With our expertise in safety and excellent public praise, standardized quality management system and professional service system throughout the years, AIYI Technologies has already become a leading brand in the gas & dust safety industry in China. AIYI Technologies has been providing products and services for worldwide well-known enterprises and has extended its businesses in pharmaceuticals, agrochemicals, environmental protection, automobile, fodder, and food. The product quality and professional service of AIYI Technologies have been highly regarded and widely acclaimed among worldwide clients.

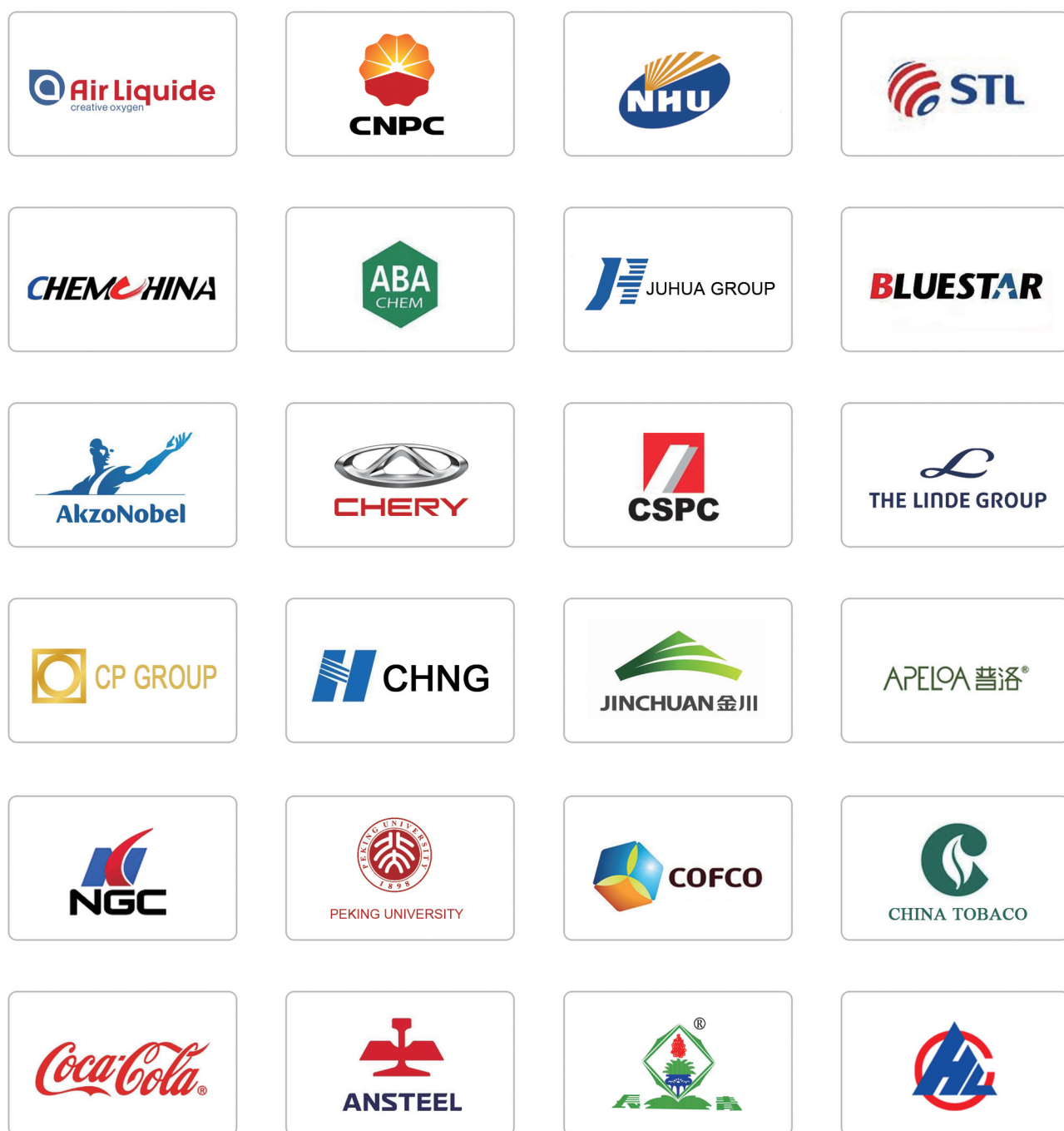

CATALOG

GAS DETECTION SYSTEM 07

- AG310 SERIES GAS DETECTOR 11
- AG210 SERIES GAS DETECTOR 14
- AG200 SERIES GAS DETECTOR 17
- EX-PROOF SOUND LIGHT ALARM 20
- AGS1600F CONTROL PANEL 22
- AGS1000 CONTROL PANEL 25
- JUDD CONTROL PANEL 27
- IPC CPNTROL SYSTEM 30

PORTABLE GAS DETECTOR 31

- PORTABLE SINGLE GAS DETECTOR 34
- PORTABLE MULTI GAS DETECTOR 36
- PORTABLE 4 GAS DETECTOR 38
- PORTABLE METHANE GAS DETECTOR 40
- PORTABLE SAMPLING PUMP 42

DUST MONITORING SYSTEM 44

- DUST MONITOR 46



GAS DETECTION SYSTEM

Gas detection system can be widely applied in places such as petrochemical engineering, chemical engineering, steel, metallurgy, pharmaceuticals, electricity, food, and logistics where the monitoring of flammable and toxic gas is needed.

The system is made of gas detector, controller and sound-light alarm, and the gas concentration data will be uploaded to the control panel. The controller collectively displays the gas concentration data of different monitoring points, and the sound-light alarm will be set off in case that any concentration exceeds over the default value. Linkage feature can be realized and the data can be also uploaded to host systems such as DCS/IPC.

FUNCTION

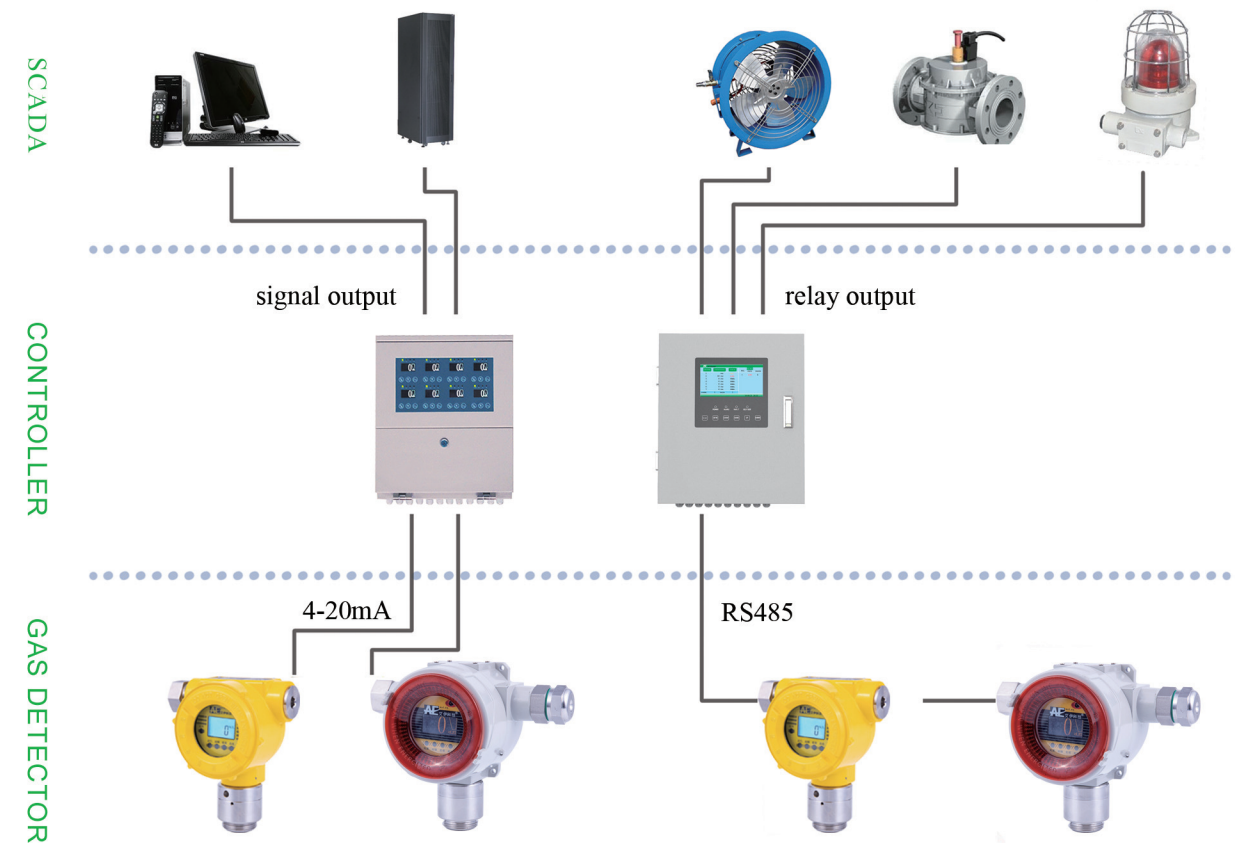

DIAGRAM of GAS DETECTION SYSTEM

1. gas detector

The gas detector is fixed in areas such as the workshop, warehouse, and storage tank for real-time monitoring of the concentration of flammable and toxic gases.

2. zone control

The controller collectively displays the gas concentration, and the sound-light alarm will be set off in case that any concentration exceeds over the default value.

3. The interlock control

It comes with relay output and fault output for the performing of automatic fan, spray, valve, and alarm.

4. The host computer

Standard 4-20mA and RS485 signal output, compatible with host computers such as DCS/PLC/IPC.

SELECTION GUIDE

QUICK SELECTION TABLE 1 -- FIXED GAS DETECTOR

Description	AG310 series					AG210 series				AG200 series		
	GTQ-AF110	GTQ-AF111	AF110-R	AG310	AG311	AG210	AG211	GTQ-Anr-A	GTQ-Anr-D	AG200	Anr-N	Anr-S
Gas detected												
combustible gas-catalytic	●	●	-	-	-	-	-	●	●	-	●	●
combustible gas-infrared	-	-	●	-	-	-	-	-	-	-	-	-
toxic gas-electrochemical	-	-	-	●	●	●	●	-	-	●	-	-
toxic gas-PID	-	-	-	●	●	●	●	-	-	●	-	-
toxic gas-infrared	-	-	-	●	●	●	●	-	-	●	-	-
toxic gas-semiconductor	-	-	-	●	●	-	-	-	-	-	-	-
Display												
OLED	●	●	●	●	●	-	-	-	-	-	-	-
LCD	-	-	-	-	-	●	●	●	●	-	-	-
Signal output												
4-20mA	●	-	●	●	-	●	-	●	-	●	●	-
RS485	-	●	-	-	●	-	●	-	●	●	-	●
Wiring												
three-wire	●	-	●	●	-	●	-	●	-	●	●	-
four-wire	-	●	-	-	●	-	●	-	●	●	-	●

Note:

- means available, - means unavailable;
- both oxygen and toxic gas are detected in electrochemical principle, so the toxic gas includes oxygen in the above table.

QUICK SELECTION TABLE 2 -- CONTROL PANEL

Description	AGS1600F	AGS1000	AGS1000B	AGS1000D	JUDD	JUDD-S
Gas detected						
combustible gas	●	●	●	●	●	●
toxic gas	-	●	●	●	●	●
Display						
LCD	●	●	●	●	-	-
OLED	-	-	-	-	●	●
Signal input						
4-20mA	●	●	●	●	●	●
RS485	-	●	●	●	-	-
Wiring						
three-wire	●	●	●	●	●	●
four-wire	-	●	●	●	-	-
Channels	4	1-64	1-64	1-64	1-8	32-128
Installation						
wall-mounted type	●	●	●	●	●	-
cabinet type	-	-	-	-	-	●
UPS	-	-	●	-	-	-
Explosion-proof	-	-	-	●	-	-

Note: The channels of AGS1000, AGS1000B, AGS1000D, JUDD, JUDD-S can be customized.

QUICK SELECTION TABLE 3 -- GAS DETECTED

Gas	Measure Range	Principle	Resolution	GTQ-AF110	GTQ-AF111	GTQ-AF110-R	GTQ-Anr-D	GTQ-Anr-N	GTQ-Anr-S	AG200	AG211	AG210	AG310	AG311	AG200
Combustible gas	0-100%LEL	Catalytic	1%LEL	●	-	-	●	-	-	-	-	-	-	-	-
Oxygen	0-100%LEL	Infrared	1%LEL	-	-	●	-	-	-	-	-	-	-	-	-
Carbon monoxide	0-30%VOL	Electrochemical	0.1%VOL	-	-	-	-	-	-	-	-	-	-	-	-
Hydrogen sulphide	0-1000µmol/mol	Electrochemical	1µmol/mol	-	-	-	-	-	-	-	-	-	-	-	-
Chlorine	0-100µmol/mol	Electrochemical	1µmol/mol	-	-	-	-	-	-	-	-	-	-	-	-
Sulphur dioxide	0-20µmol/mol	Electrochemical	0.1µmol/mol	-	-	-	-	-	-	-	-	-	-	-	-
Ammonia	0-100µmol/mol	Electrochemical	1µmol/mol	-	-	-	-	-	-	-	-	-	-	-	-
Nitric oxide	0-250µmol/mol	Electrochemical	1µmol/mol	-	-	-	-	-	-	-	-	-	-	-	-
Nitrogen dioxide	0-20µmol/mol	Electrochemical	0.1µmol/mol	-	-	-	-	-	-	-	-	-	-	-	-
Hydrogen chloride	0-30µmol/mol	Electrochemical	0.1µmol/mol	-	-	-	-	-	-	-	-	-	-	-	-
Ozone	0-1µmol/mol	Electrochemical	0.01µmol/mol	-	-	-	-	-	-	-	-	-	-	-	-
Ethylene oxide	0-20µmol/mol	Electrochemical	0.1µmol/mol	-	-	-	-	-	-	-	-	-	-	-	-
Formaldehyde	0-20µmol/mol	Electrochemical	0.1µmol/mol	-	-	-	-	-	-	-	-	-	-	-	-
Methanol	0-20µmol/mol	Electrochemical	0.1µmol/mol	-	-	-	-	-	-	-	-	-	-	-	-
Phosphine	0-5µmol/mol	Electrochemical	0.1µmol/mol	-	-	-	-	-	-	-	-	-	-	-	-
Hydrogen	0-1000µmol/mol	Electrochemical	1µmol/mol	-	-	-	-	-	-	-	-	-	-	-	-
Fluorine	0-1µmol/mol	Electrochemical	0.01µmol/mol	-	-	-	-	-	-	-	-	-	-	-	-
Hydrogen fluoride	0-10µmol/mol	Electrochemical	0.1µmol/mol	-	-	-	-	-	-	-	-	-	-	-	-
Hydrogen cyanide	0-50µmol/mol	Electrochemical	0.1µmol/mol	-	-	-	-	-	-	-	-	-	-	-	-
Phosgene	0-1µmol/mol	Electrochemical	0.01µmol/mol	-	-	-	-	-	-	-	-	-	-	-	-
Arsenic hydride	0-1/20µmol/mol	Electrochemical	0.01µmol/mol	-	-	-	-	-	-	-	-	-	-	-	-
Silane	0-50µmol/mol	Electrochemical	0.1µmol/mol	-	-	-	-	-	-	-	-	-	-	-	-
Acrylonitrile	0-20µmol/mol	Electrochemical	0.1µmol/mol	-	-	-	-	-	-	-	-	-	-	-	-
Carbon disulfide	0-20µmol/mol	Electrochemical	0.1µmol/mol	-	-	-	-	-	-	-	-	-	-	-	-
Ethanol	0-20µmol/mol	Electrochemical	0.1µmol/mol	-	-	-	-	-	-	-	-	-	-	-	-
Sulfur hexafluoride	0-1000µmol/mol	Infrared	1µmol/mol	-	-	-	-	-	-	-	-	-	-	-	-
Methane	0-5%/100%VOL	Infrared	0.1%VOL	-	-	-	-	-	-	-	-	-	-	-	-
Carbon dioxide	0-5%/100%VOL	Infrared	0.1%VOL	-	-	-	-	-	-	-	-	-	-	-	-
Toluene	0-20µmol/mol	PID	0.1µmol/mol	-	-	-	-	-	-	-	-	-	-	-	-
Xylene	0-20µmol/mol	PID	0.1µmol/mol	-	-	-	-	-	-	-	-	-	-	-	-
Benzene	0-20µmol/mol	PID	0.1µmol/mol	-	-	-	-	-	-	-	-	-	-	-	-
Acetic acid	0-1000µmol/mol	PID	1µmol/mol	-	-	-	-	-	-	-	-	-	-	-	-
Volatile organic compounds	0-20µmol/mol 0-1000µmol/mol	PID	0.1µmol/mol 1µmol/mol	-	-	-	-	-	-	-	-	-	-	-	-

Note: 1. Any gas that not mentioned above, just contact AIYI Technologies for further information; 2. 1µmol/mol=1ppm



AG310 SERIES GAS DETECTOR

AG310 series including model GTQ-AF110, GTQ-AF111, AF110-R, AG310, AG311. These gas detectors are suitable for detecting the combustible and toxic gases in hazardous areas. The product adopts the integrated design of sound and light alarm, which can effectively warn all kinds of gas leakage hazards; the smart sensor modular design supports hot plugging and easy maintenance; the product is equipped with an infrared remote control, which can realize completely no cover operation. IP66 protection can be applied to all kinds of bad occasions.

Features

- integrated design with sound and light alarm.
- The patented sensor module integrates the sensor and calibration information into a replaceable module. Suitable to replace the sensor module without calibration and ready-to-use when connect new sensor module even it's a different gas sensor, much convenient.
- IP66 design with body material in stainless steel and aluminum alloy, suitable for harsh environments.
- High-brightness OLED display, capable to see readings in any angle.
- Built-in three relays(alarm-1, alarm-2, fault), multi-functional control is possible.
- Full English menu, remote control operation.
- Complete product certification (ATEX, SIL, CNEX, CCCF, etc.)

Specification

Description	Specifications	GTQ-AF110	GTQ-AF111	AF110-R	AG310	AG311
Gas Detected						
Ex	catalytic combustion	●	●	-	-	-
	infrared	-	-	●	-	-
toxic	ECD,IR,PID,semiconductor	-	-	-	●	●
Function						
measure range	see QUICK-SELECTION-TABLE	●	●	●	●	●
response time*	T90≤30S	●	●	●	-	-
	T90≤60/180S	-	-	-	●	●
accuracy*	≤±5%F.S	●	●	●	●	●
repeatability*	≤2%F.S	●	●	●	●	●
Electric						
power supply	18-28VDC(standard 24VDC)	●	●	●	●	●
power consumption	≤3.5W	●	●	●	-	-
	≤2W	-	-	-	●	●
signal output	4-20mA	●	-	●	●	-
	RS485	-	●	-	-	●
wiring	three-wire	●	-	●	●	-
	four-wire	-	●	-	-	●
suitable cable	RVVP3*1.5mm ²	●	-	●	●	-
	RVVP4*1.0mm ²	-	●	-	-	●
relay output	3 passive relays (250VAC/5A 30VDC/5A)	●	●	●	●	●
Display & Operation						
display	OLED display	●	●	●	●	●
indicator light	power,fault,alarm-1,alarm-2	●	●	●	●	●
operation method	remote control	●	●	●	●	●
Environment						
ingress protection	IP66	●	●	●	●	●
operating temp.	-40℃~70℃	●	●	●	-	-
	-20℃~60℃	-	-	-	●	●
operating humidity	10~95%RH non-condensing	●	●	●	●	●
operating pressure	80-120kPa	●	●	●	●	●
Structure						
body material	ADC12 aluminum +316L S/S	●	●	●	●	●
close nipple	NPT1/2	●	●	●	●	●
weight	about 2kg	●	●	●	●	●
dimensions	145*202*100mm(H*W*D)	●	●	●	●	●
Certificates						
CPA	2015C563-32	●	●	●	●	●
EX	Exdib II CT6 Gb	●	●	●	●	●
CCCF	073184850122ROM	●	-	-	-	-
	073184850123ROM	-	●	●	-	-
SIL	SIL2	●	●	●	●	●
ATEX	Ex dbib II CT6 Gb	-	-	-	●	●

Note:* refers to there's some difference vary from different gas, please contact the manufacturer for details.

Dimensions

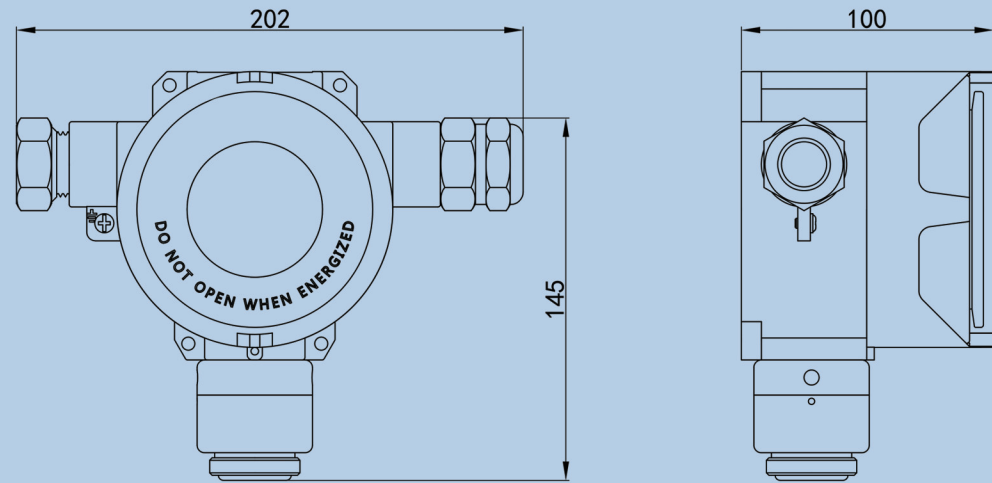

Wiring

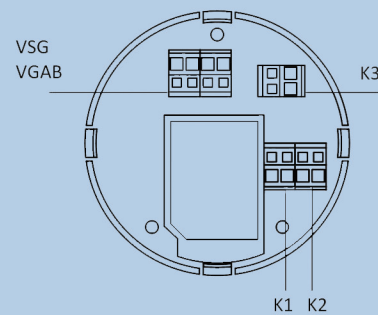

Terminals	Description
V	24V +
S	4-20mA signal output
G	24V -
A B	RS485 signal output
K1	relay output for alarm-1
K2	relay output for alarm-2
K3	relay output for fault



AG210 SERIES GAS DETECTOR

AG210 series including model AG210, AG211, GTQ-Anr-A, GTQ-Anr-D. These gas detectors are a classic product of AIYI Technologies, which is suitable for most areas where it is necessary to detect flammable gas, oxygen, and toxic gas. The product responds quickly with an advanced gas sensor; ingress protection to IP66.

Features

- Advanced gas sensors, fast response with a long lifespan, safer and more reliable.
- IP66 design with body material in stainless steel and aluminum alloy, suitable for harsh environments.
- LCD display, with LED indicators.
- Built-in 3 relay output and compatible with optional sound-light alarm
- Full English menu, remote control operation.
- Complete product certification (ATEX, SIL2, CNEX, CCCF, etc.)

Specifications

Description	Specifications	GTQ-Anr-A	GTQ-Anr-D	AG210	AG211
Gas Detected					
Ex	catalytic combustion	●	●	-	-
toxic gas	electrochemical	-	-	●	●
	infrared	-	-	●	●
	PID	-	-	●	●
Function					
measure range	see QUICK-SELECTION-TABLE	●	●	●	●
response time*	T90≤30S	●	●	-	-
	T90≤60/180S	-	-	●	●
accuracy*	≤±5%F.S	●	●	●	●
repeatability*	≤2%F.S	●	●	●	●
Electric					
power supply	18-28VDC (standard 24VDC)	●	●	●	●
power consumption	≤3.5W	●	●	-	-
	≤2W	-	-	●	●
signal output	4-20mA	●	-	●	-
	RS485	-	●	-	●
wiring	three-wire	●	-	●	-
	four-wire	-	●	-	●
suitable cable	RVVP3*1.5mm ²	●	-	●	-
	RVVP4*1.0mm ²	-	●	-	●
relay output	3 passive relays	●	●	●	●
Display&operation					
display	LCD display	●	●	●	●
indicator light	power,fault,alarm-1,alarm-2	●	●	●	●
operation method	remote control	●	●	●	●
Environment					
ingress protection	IP66	●	●	●	●
operating temperature	-40℃~70℃	●	●	-	-
	-20℃~60℃	-	-	●	●
operating humidity	10~95%RH non-condensing	●	●	●	●
operating pressure	80-120kPa	●	●	●	●
Structure					
body material	ADC12 aluminum +316L S/S	●	●	●	●
close nipple	NPT1/2	●	●	●	●
weight	about 1.45kg	●	●	●	●
dimensions	157*133*79mm(H*W*D)	●	●	●	●
Certificates					
CPA	2013C293-32	●	●	●	●
EX	Exd II CT6 Gb	●	●	●	●
	Ex tD A21 IP66 T80℃	●	●	●	●
CCCF	073184850124ROM	●	●	-	-
SIL	SIL2	●	●	●	●
ATEX	Ex db II CT6 Gb	-	-	●	-

Note: * refers to there's some difference vary from different gas, please contact the manufacturer for details.

Dimensions

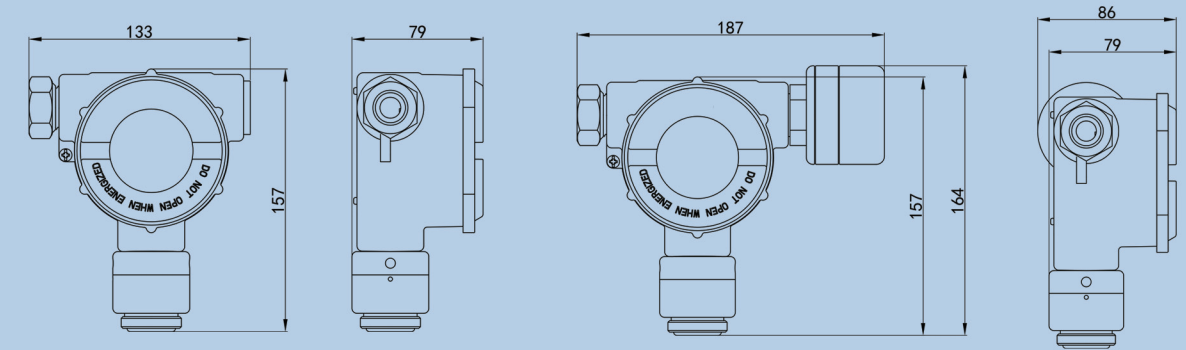

Wiring

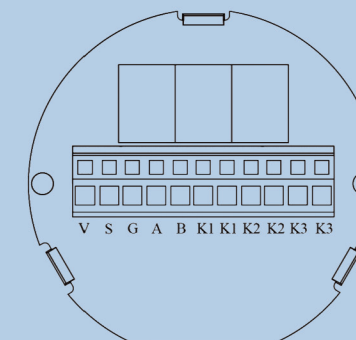

Terminals	Description
V	24V +
S	4-20mA signal output
G	24V -
A B	RS485 signal output
K1	relay output for alarm-1
K2	relay output for alarm-2
K3	relay output for fault



AG200 SERIES GAS DETECTOR

Anr-N, Anr-S, AG200 gas detector is a classic product of AIYI Technologies, which is suitable for most areas where it is necessary to detect flammable gas, oxygen, and toxic gas. The product responds quickly with an advanced gas sensor; ingress protection to IP65.

Features

- Advanced gas sensors, fast response with a long lifespan, safer and more reliable.
- IP65 design with body material in stainless steel and aluminum alloy, suitable for harsh environments.
- 4-20mA/RS485 signal output that can upload the signal to the control panel.
- Built-in relay and compatible with sound light alarm
- Complete product certification (ATEX, SIL, CCCF, etc.)

Specification

Description	Specifications	Anr-N	Anr-S	AG200
Gas Detected				
Ex	catalytic combustion	●	●	-
toxic	electrochemical	-	-	●
Function				
measure range	see QUICK-SELECTION-TABLE	●	●	●
response time*	T90≤30S	●	●	-
	T90≤60/180S	-	-	●
accuracy*	≤±5%F.S	●	●	●
repeatability*	≤2%F.S	●	●	●
Electric				
power supply	18-28VDC(standard 24VDC)	●	●	●
power consumption	≤2.5W	●	●	-
	≤1.5W	-	-	●
signal output	4-20mA	●	-	●
	RS485	-	●	●
wiring	three-wire	●	-	●
	four-wire	-	●	●
suitable cable	RVVP3*1.5mm ²	●	-	●
	RVVP4*1.0mm ²	-	●	●
relay output	1 passive relay (250VAC/5A 30VDC/5A)	●	●	●
Display				
OLED screen	N/A	●	●	●
Environment				
ingress protection	IP65	●	●	●
operating temperature	-40℃~70℃	●	●	-
	-20℃~60℃	-	-	●
operating humidity	10~95%RH non-condensing	●	●	●
operating pressure	80-120kPa	●	●	●
Structure				
body material	ADC12 aluminum alloy +316L stainless steel	●	●	●
close nipple	NPT1/2	●	●	●
weight	about 1.3kg	●	●	●
dimensions	165*140*78mm(H*W*D)	●	●	●
Certificates				
CPA	2009C170-32	●	●	●
EX	Exd II CT6 Gb	●	●	●
CCCF	073184850117ROM	●	-	-
	073184850119ROM	-	●	-
SIL	SIL2	●	●	●
ATEX	Exdb II CT6 Gb	●	●	●

Note: * refers to there's some difference vary from different gas, please contact the manufacturer for details.

Dimensions

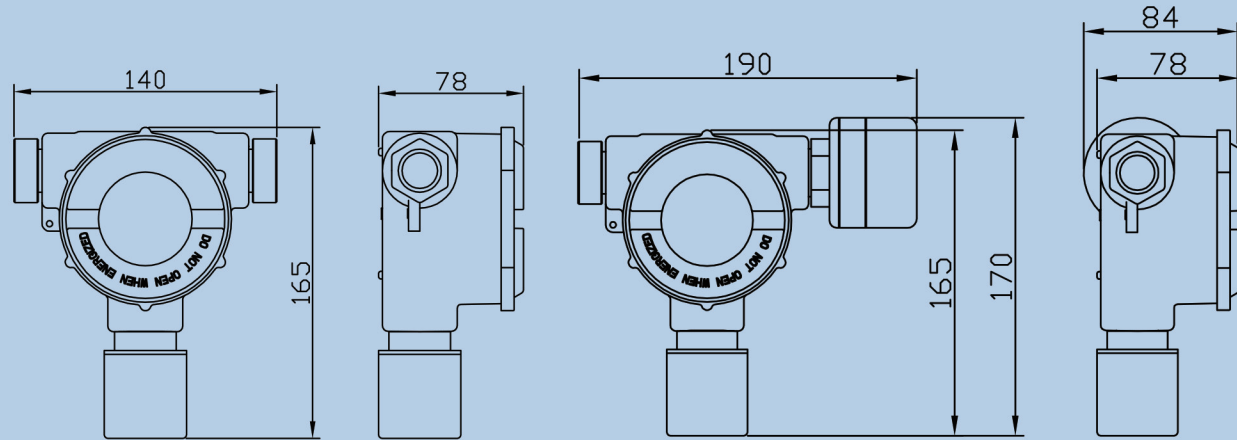

Wiring

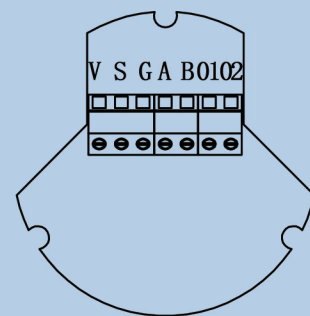

Terminals	Description
V	24V +
S	4-20mA signal output
G	24V -
A B	RS485 signal input
01 02	Relay output

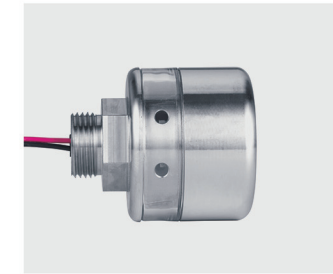

EX-PROOF SOUND LIGHT ALARM

The Gary sound-light alarms is optional device for the gas detector. It'll automatically alert with sound and light when the detected gas exceeds the standard. The product is a durable design with stainless steel, and standard threaded interface makes it compatible with other electrical equipment also.

Features

- Compact size, standard threaded interface for easy installation.
- IP66 design with all 316L stainless steel body, suitable for harsh environments.
- 360° light alarm, high loudness buzzer, effective reminder.
- Compatible with gas detectors of AIYI Technologies or separately.
- 12-28VDC wide range of power supply with anti-reverse wiring function.

Specifications

Function	
alarm method	sound and light
light color	red
light intensity	>900mcd
sound intensity	>100dB
Environment	
ingress protection	IP66
operating temperature	-40°C ~ 70°C
operating humidity	10~95%RH non-condensing
operating pressure	80-120kPa
Electric	
power supply	12-28VDC(standard 24VDC)
power consumption	≤3W
Structure	
body material	304 stainless steel+nylon
close nipple	M26*2
weight	about 0.6kg
dimensions	φ60*70mm
Certificate	
EX	Exd II CT6 Gb

Dimensions

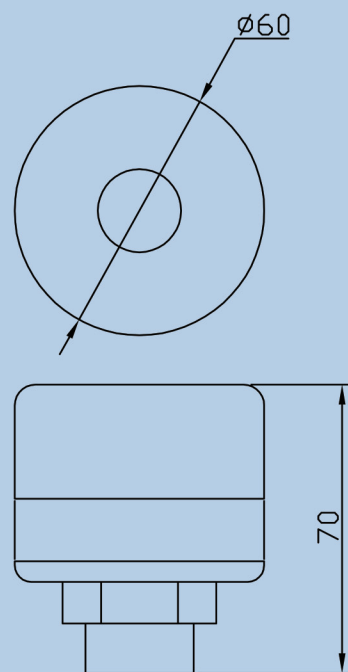

AGS1600F CONTROL PANEL

The AGS1600F control panel is designed with 1 to 4 channels, which can monitor the alarm in real time, and built-in relay output to realize the function of controlling the interlocking equipment. According to different needs, the product can be widely used in petroleum, chemical, energy, steel, metallurgy, gas, and other industries.

Features

- Products passed the national CCCF certification.
- Large-screen LCD graphics display with rich content.
- Built-in 3 relays for multi-functional control.
- Built-in UPS power supply to prevent potential hazards caused by accidental power failure.
- Wall-mounted carbon steel casing, more durable.
- compatible with fixed gas detectors.

Wiring

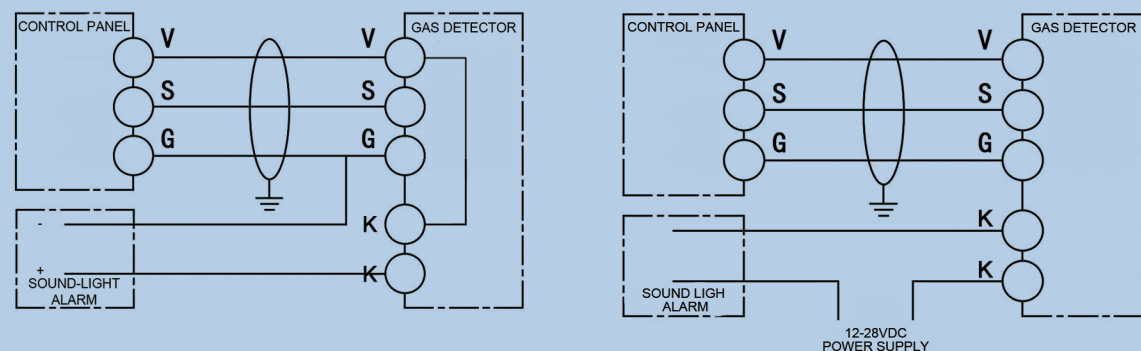

Specifications

Description	Specifications	AGS1600F
Function		
channels	4	●
suitable detector	combustible gas detector in 4-20mA only	●
Electric		
power supply	220VAC	●
power consumption	≤6W	●
signal input	4-20mA	●
signal output	RS485	●
wiring	three-wire	●
suitable cable	RVVP3*1.5mm ²	●
relay output	3 passive relay (250VAC/5A;30VDC/5A)	●
Display & Operation		
display	color LCD screen, resolution 480*272	●
indicator light	alarm,fault,power,power fault,backup power fault	●
operation method	button	●
Environment		
operating temp.	0℃~40℃	●
operating humidity	10~95%RH non-condensing	●
operating pressure	80-120kPa	●
Structure		
body material	carbon steel with electrostatic spraying	●
weight	about 6kg	●
dimensions	345*230*105mm(H*W*D)	●
Certificates		
CCCF	073194850084R0M	●
SIL	SIL2	●

Dimensions

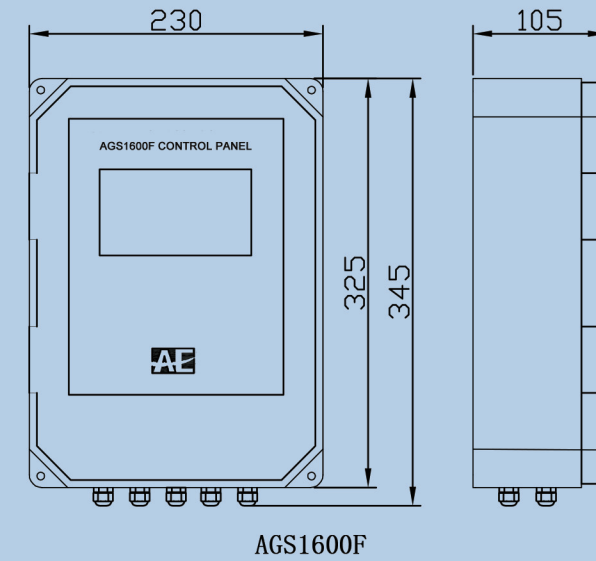

Wiring

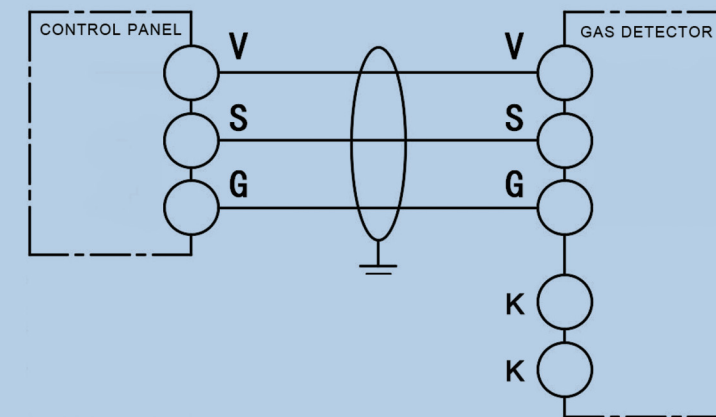



AGS1000 SERIES CONTROL PANEL

The AGS1000 series control panel is used to connect gas detectors of AIYI Technologies. Each channel configuration is customizable with reliable performance. Among them, AGS1000B is equipped with UPS uninterruptible power supply, and AGS1000D is an explosion-proof type, which can meet the different needs of different places. They are widely used in petroleum, chemical, energy, steel, metallurgy, gas, and other industries.

Features

- 4-20mA, RS485 signal input is optional.
- Up to 64 channels (RS485), up to 32 channels (4-20mA),
- Large color LCD display with rich information and sound alarm.
- Real-time status indication with light for power, alarm, fault and self-test.
- Multi functions with channel block, alarm set, and fault alarm. Support to check alarm records and fault records.
- AGS1000B has a built-in UPS, which can still work normally after the main power is cut off.
- Built-in 3 relays (alarm-1, alarm-2 and fault)
- Wall-mounted carbon steel housing, much durable.

Specifications

Description	Specifications	AGS1000	AGS1000B	AGS1000D
Function				
channels	4-20mA: 8/16/24/32 is optional RS485: up to 64 channels	●	●	●
suitable detector	detectors with 4-20mA or AE-RS485	●	●	●
Electric				
power supply	220VAC	●	●	●
power consumption	≤8W	●	●	●
signal input	RS485/4-20mA	●	●	●
signal output	RS485	●	●	●
wiring	4-20mA: three-wire RS485: four-wire	●	●	●
suitable cable	RVVP3*1.5/4*1.0mm2	●	●	●
relay output	3 passive relay (250VAC/5A 30VDC/5A)	●	●	●
Display & Operation				
display	LCD	●	●	●
indicator light	alarm, fault, power, self-test power,backup power,alarm,fault,block	●	-	●
operation method	button	●	●	●
Environment				
operating temp.	0℃~40℃	●	●	●
operating humidity	10~95%RH non-condensing	●	●	●
operating pressure	80-120kPa	●	●	●
Structure				
body material	carbon steel withelectrostatic spraying	●	●	●
weight	about 7.5kg	●	-	-
	about 16.5kg	-	●	-
	about 50kg	-	-	●
Dimensions	500*360*100mm(H*W*D)	●	-	-
	590*400*155mm(H*W*D)	-	●	-
	700*620*244mm (H*W*D)	-	-	●
Certificate				
SIL	SIL2	●	-	-
EX	Exd II BT6	-	-	●



JUDD CONTROL PANEL

The JUDD and JUDD-S control panel is a standard modular design. Each module has an independent display function. It can be divided into wall-mounted or cabinet-type according to the channels. The control panel has built-in relay output, which is compatible with 4-20mA signal gas detectors, suitable for petroleum, chemical, energy, steel, metallurgy, gas, and other industries.

Features

- Modular design, more flexible solution.
- The OLED graphic display is clearly visible under strong light.
- Built-in relays are capable of interlock control.
- Aluminum alloy/carbon steel, much durable.
- Supports connect with 4-20mA gas detectors.

Specifications

Description	Specifications	JUDD	JUDD-S
Function			
channels	1~8	●	-
	>16	-	●
suitable detector	detector with 4-20mA only	●	●
Electric			
power supply	220VAC	●	●
power consumption	each channel ≤1W	●	●
signal input	4-20mA	●	●
signal output	4-20mA	●	●
wiring	three-wire	●	●
suitable cable	RVVP3*1.5mm ²	●	●
relay output	2 passive relay (250VAC/5A 30VDC/5A)	●	●
Display & Operation			
display	OLED screen, resolution in 128*64	●	●
indicator light	power, fault, alarm-1, alarm-2	●	●
operation method	button	●	●
Environment			
operating temperature	0℃~40℃	●	●
operating humidity	10~95%RH non-condensing	●	●
operating pressure	80-120kPa	●	●
Structure			
body material	aluminum alloy(for single channel) carbon steel with electrostatic spraying (for multi channels)	●	-
weight	about 0.24kg for single channel	●	●
dimensions	145*65*43mm(H*W*D) single channel 467*359*99mm(H*W*D) multi channels 2100*800*600mm(H*W*D) JUDD-S	●	-
Certificate			
SIL	SIL2	●	-

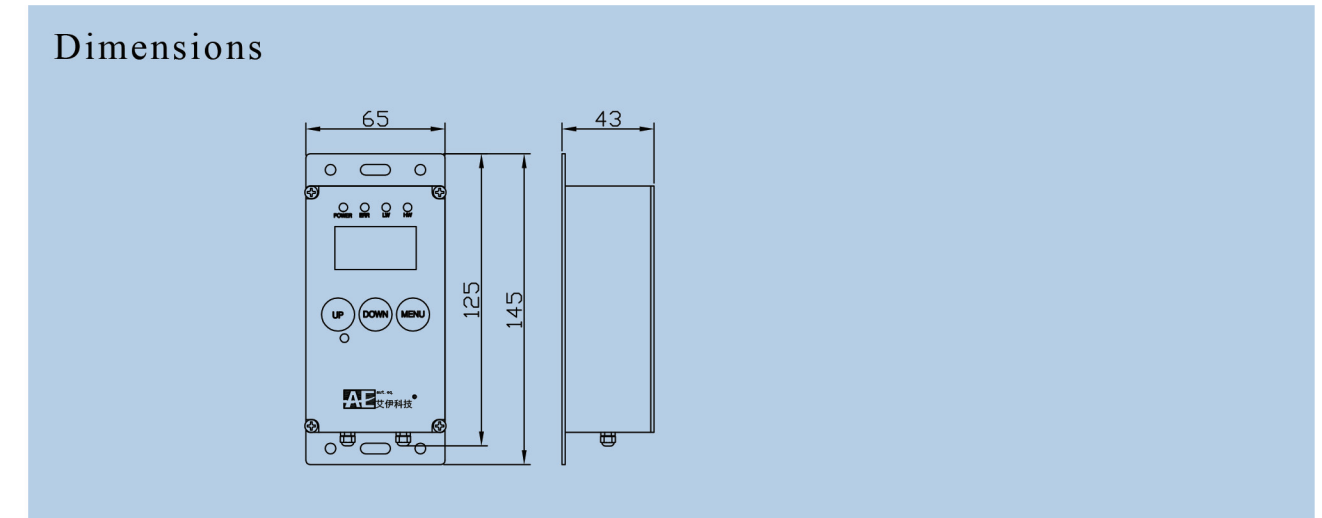

Dimensions

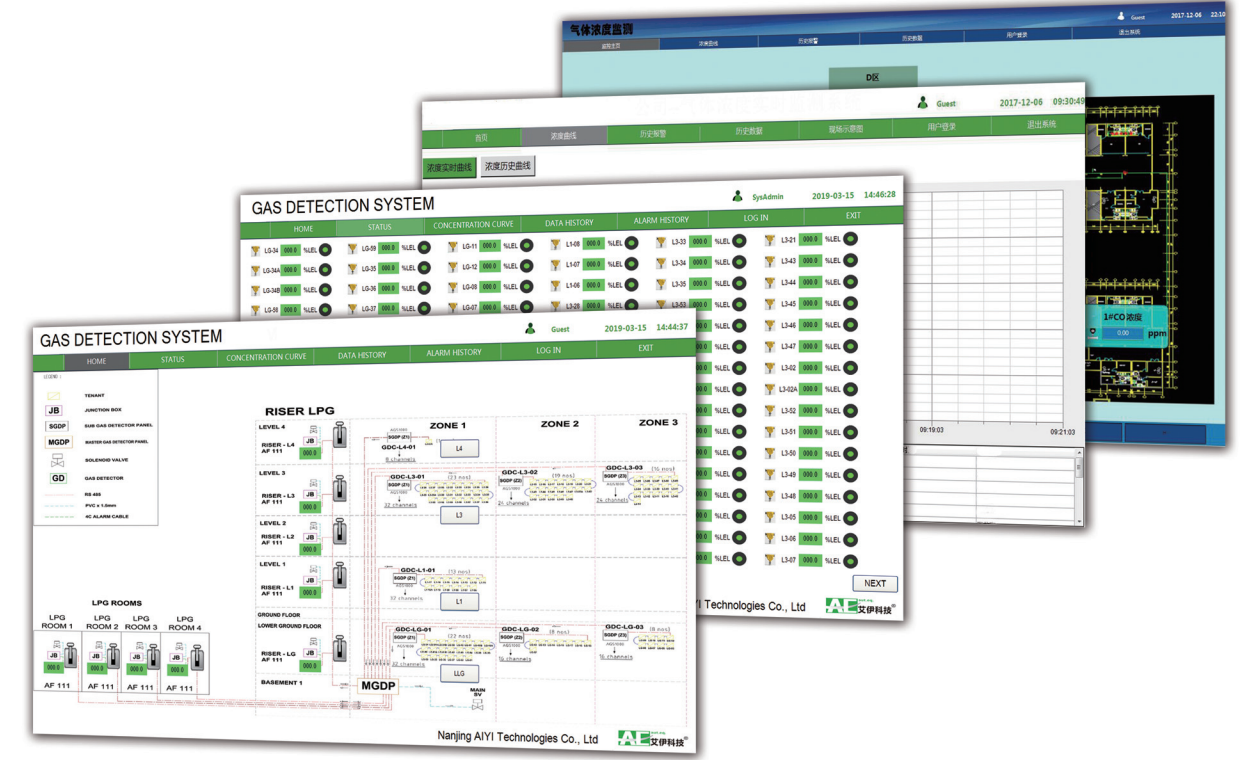
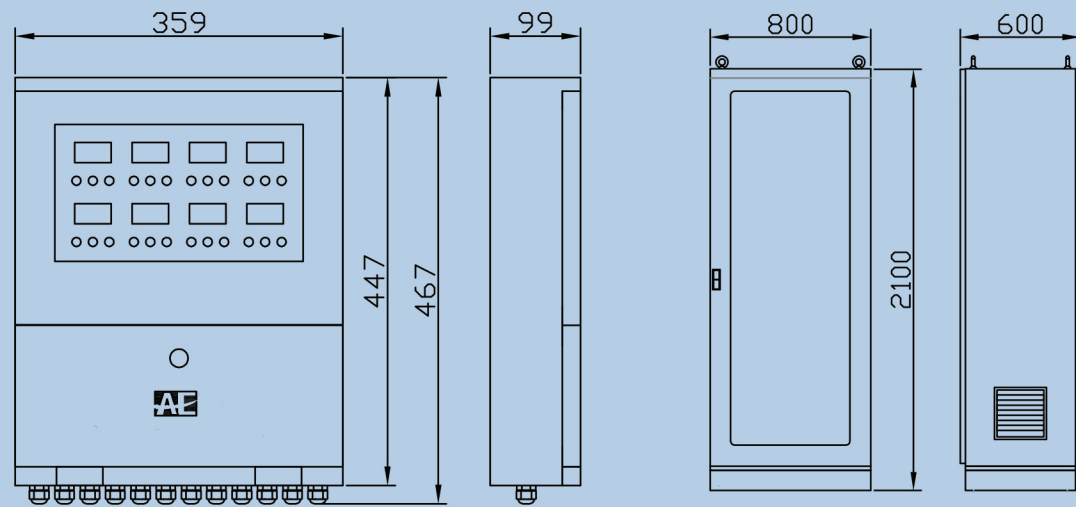

IPC CONTROL SYSTEM

Wiring

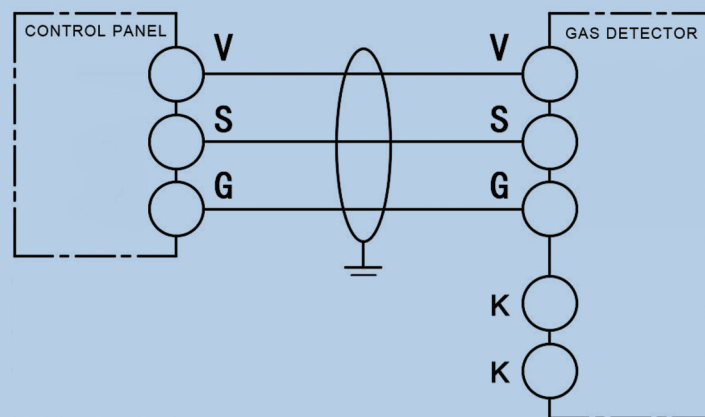

Industrial personal computer (IPC) control system can realize the function of real-time readings display, history record, concentration curve, remote control (via PLC) and other functions.

The IPC system is a customized solution, which can support up to 500 detection data, and customized functions according to different requirement. The system is mainly composed of industrial computer and monitoring software.

Functions

- Historical and real-time concentration curve query.
- Displays the concentration information in map, much visual.
- Red, yellow, green three-color light alarm for each detection point.
- Alarm record query, including historical alarm record, alarm time, recovery time.
- Various information such as date, time, bit number, description, unit, alarm value, alarm type etc.
- Customized user interfaces and functions based on different requirement.



SELECTION GUIDE

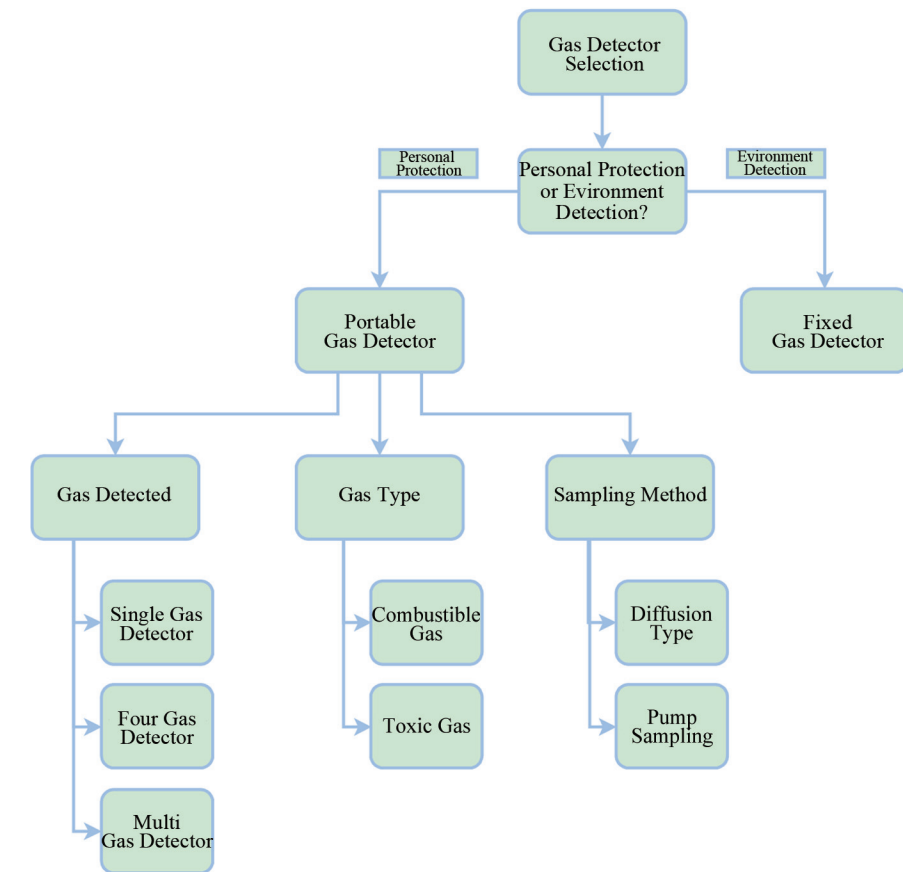

PORTABLE GAS DETECTOR

In the daily production of petrochemical engineering, steel, and chemical engineering industries, workers often encounter with flammable and toxic gases of various sorts, and accidents are easy to take place without proper safety protection. As a kind of personal safety protection instrument, portable gas detector plays an important role in industrial production safety.

The portable gas detector is small in size and easy to carry. It can be used for workshop routing inspection for side leakage, as well as in confined spaces such as flame operation inspection.



diffusion type gas detector



build-in pump gas detector



external pump gas detector

QUICK SELECTION TABLE 4 -- PORTABLE GAS DETECTOR

Description	AGH5100	AGH5100M	AGH6100	AGH6100F	AGH6200	AGH6200F	AGH8100	AGH8200
The number of sensors								
1	●	●	-	●	-	●	●	●
4 in 1	-	-	-	-	●	-	-	-
1~4, optional	-	-	●	-	-	-	-	-
Gas detected								
combustible gas-catalytic	-	-	●	●	●	●	-	-
combustible gas-semiconductor	-	-	-	-	-	-	●	●
toxic gas-electrochemical	●	●	●	-	●	-	-	-
toxic gas-PID	-	-	●	-	-	-	-	-
toxic gas-infrared	-	-	●	-	-	-	-	-
Sampling method								
diffusion	●	●	●	●	●	●	-	●
built-in pump	-	-	-	-	-	-	●	-
Certificates								
CPA	●	●	●	●	●	●	●	-
EX	●	●	●	●	●	●	●	●
ATEX	-	-	●	●	-	-	-	-
CCCF	-	-	-	-	-	●	-	-

QUICK SELECTION TABLE 5 -- GAS DETECTED

Gas	Measure Range	Principle	Resolution	AGH5100	AGH5100M	AGH6100	AGH6100F	AGH6200	AGH6200F	AGH8100	AGH8200
Combustible gas	0-100%LEL	catalytic	1%LEL	-	-	●	●	●	●	-	-
Methane	0-1000μmol/mol	Semiconductor	1μmol/mol	-	-	●	●	●	●	●	●
Oxygen	0-30%VOL 0-25%VOL	Electrochemical	0.1%VOL	●	●	●	-	●	-	-	-
Carbon monoxide	0-1000μmol/mol	Electrochemical	1μmol/mol	●	●	●	-	●	-	-	-
Hydrogen sulphide	0-100μmol/mol	Electrochemical	1μmol/mol	●	●	●	-	●	-	-	-
Chlorine	0-10μmol/mol	Electrochemical	0.1μmol/mol	●	-	●	-	-	-	-	-
Sulphur dioxide	0-20μmol/mol	Electrochemical	0.1μmol/mol	●	●	●	-	-	-	-	-
Ammonia	0-100μmol/mol	Electrochemical	1μmol/mol	●	●	●	-	-	-	-	-
Nitric oxide	0-250μmol/mol	Electrochemical	1μmol/mol	●	●	●	-	-	-	-	-
Nitrogen dioxide	0-20μmol/mol	Electrochemical	0.1μmol/mol	●	●	●	-	-	-	-	-
Hydrogen chloride	0-30μmol/mol	Electrochemical	0.1μmol/mol	●	●	●	-	-	-	-	-
Ozone	0-1μmol/mol	Electrochemical	0.01μmol/mol	●	●	●	-	-	-	-	-
Ethylene oxide	0-20μmol/mol	Electrochemical	0.1μmol/mol	●	●	●	-	-	-	-	-
Formaldehyde	0-20μmol/mol	Electrochemical	0.1μmol/mol	●	●	●	-	-	-	-	-
Methanol	0-20μmol/mol	Electrochemical	0.1μmol/mol	●	●	●	-	-	-	-	-
Phosphine	0-5μmol/mol	Electrochemical	0.1μmol/mol	●	●	●	-	-	-	-	-
Hydrogen	0-1000μmol/mol	Electrochemical	1μmol/mol	●	●	●	-	-	-	-	-
Fluorine	0-1μmol/mol	Electrochemical	0.01μmol/mol	●	●	●	-	-	-	-	-
Hydrogen fluoride	0-10μmol/mol	Electrochemical	0.1μmol/mol	●	●	●	-	-	-	-	-
Hydrogen cyanide	0-50μmol/mol	Electrochemical	0.1μmol/mol	●	●	●	-	-	-	-	-
Phosgene	0-1μmol/mol	Electrochemical	0.01μmol/mol	●	●	●	-	-	-	-	-
Arsenic hydride	0-1/20μmol/mol	Electrochemical	0.01μmol/mol	●	●	●	-	-	-	-	-
Silane	0-50μmol/mol	Electrochemical	0.1μmol/mol	●	●	●	-	-	-	-	-
Acrylonitrile	0-20μmol/mol	Electrochemical	0.1μmol/mol	●	●	●	-	-	-	-	-
Carbon disulfide	0-20μmol/mol	Electrochemical	0.1μmol/mol	●	●	●	-	-	-	-	-
Ethanol	0-20μmol/mol	Electrochemical	0.1μmol/mol	●	●	●	-	-	-	-	-
Methane	0-5%/100%VOL	Infrared	0.1%VOL	-	-	●	-	-	-	-	-
Carbon dioxide	0-5%/100%VOL	Infrared	0.1%VOL	-	-	●	-	-	-	-	-
Toluene	0-20μmol/mol	PID	0.1μmol/mol	-	-	●	-	-	-	-	-
Xylene	0-20μmol/mol	PID	0.1μmol/mol	-	-	●	-	-	-	-	-
Benzene	0-20μmol/mol	PID	0.1μmol/mol	-	-	●	-	-	-	-	-
Acetic acid	0-1000μmol/mol	PID	1μmol/mol	-	-	●	-	-	-	-	-
Volatile organic compounds	0-20μmol/mol 0-1000μmol/mol	PID	0.1μmol/mol 1μmol/mol	-	-	●	-	-	-	-	-

Note: 1, Any gas that not mentioned above, just contact AIYI Technologies for further information; 2, 1μmol/mol=1ppm



PORTABLE SINGLE GAS DETECTOR

The AGH5100 & AGH5100M portable gas detector can detect toxic gases in the ambient environment. The product is fully gripped, compact, and a built-in advanced electrochemical sensor for a fast response. The double-layered body design suitable for harsh environments and single-button operation greatly reduces the possibility of misoperation.

Features

- Compact and light, it is easy to wear in a helmet, belt, etc.
- PC+TPU double-layer body, wear-resistant and drop-resistant, suitable for harsh conditions.
- Specially designed PCB board, effective against electromagnetic interference, stable work.
- High-brightness LCD display, sound, light, vibration alarm method.
- Built-in high-performance lithium-ion battery for over 20 days of operation.
- One-button design, easy to use, reducing the possibility of misoperation.
- Compatible with a external sampling pump for confined space usage.

Specifications

Description	Specifications	AGH5100	AGH5100M
Function			
gas detected	toxic gas, O ₂ O ₂ /CO/H ₂ S/SO ₂	● -	- ●
measure range	see QUICK-SELECTION-TABLE	●	●
response time*	T90≤30/60/180S	●	●
accuracy*	≤±5%FS	●	●
repeatability*	≤2%FS	●	●
sampling method	diffusion	●	●
Electric			
battery	rechargeable Li-battery 3.7V 1500mAh CR2 Li-battery 3V 1400mAh	● -	- ●
continuous operation	over 20 days in room temp.	●	-
	2 year	-	●
Alarm			
alarm method	Sound,LED light,vibration	●	●
sound intensity	>90dB	●	●
Display and Operation			
display	segment code LCD screen	●	●
Environment			
ingress protection	IP67	●	●
operating temp.	-20℃~60℃	●	●
operating humidity	10~95%RH non-condensing	●	●
operating pressure	80-120kPa	●	●
Structure			
body material	PC+TPU	●	●
weight	About 139g	●	●
dimensions	98*67.5*50mm(H*W*D)	●	●
Certificates			
EX	Exib II CT4 Gb Exia II CT4 Ga	● -	- ●

Note:* refers to there's some difference vary from different gas, please contact the manufacturer for details.



PORTABLE MULTI GAS DETECTOR

The AGH6100 gas detector can detect a variety of gases. The product supports up to 4 gases for simultaneous detection. The gas sensor can be flexibly selected according to the site requirements. The product has an intrinsically safe design with IP66 protection and suitable for harsh environments. The large LCD screen displays various information such as gas concentration and alarm history. The product supports USB data upload, which can easily export alarm record information.

Features

- Many gases are detectable with flexible selection, up to 4 gases in one detector.
- Support alarm record USB upload, no need any software.
- Sound, light, vibration alarm method, effective warning.
- High-brightness display with gravity sensing for easy viewing at all angles.
- The TPU+PC housing, more wear-resistant.
- Specially designed PCB board, effective against electromagnetic interference, stable work.
- Ingressive protection in IP66 rating, dustproof and waterproof.
- Compatible with a sampling pump for confined space usage.

Dimensions

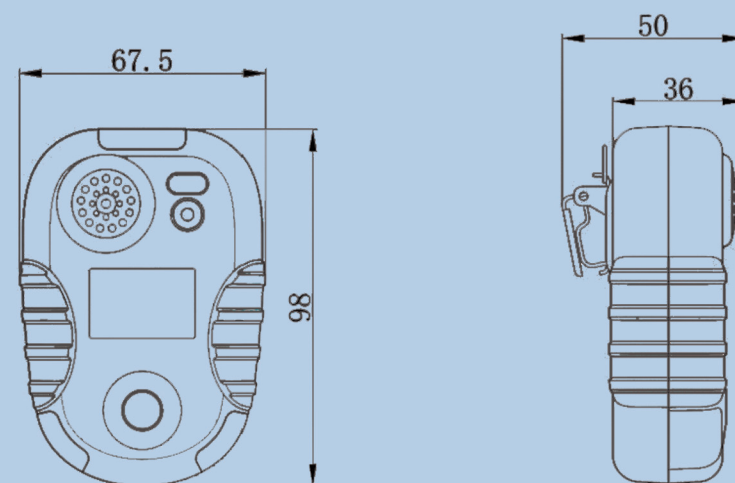

Specifications

Description	Specifications	AGH6100	AGH6100F
Function			
gas detected	combustible gas	●	●
	O ₂ , toxic gas	●	-
measure range	see QUICK-SELECTION-TABLE	●	●
response time*	T ₉₀ ≤ 30/60/180S	●	●
accuracy*	≤ ±5%F.S	●	●
repeatability*	≤ 2%F.S	●	●
sampling method	diffusion	●	●
Electric			
battery	rechargeable Li-battery 2200mAh	●	●
continuous operation	at least 18 hours after a typical 4 hours full charge	●	●
Alarm			
alarm method	sound, LED light, vibration	●	●
sound intensity	> 90dB	●	●
Display and Operation			
display	LCD	●	●
button	3 (UP, OK, DOWN)	●	●
Environment			
ingress protection	IP66	●	●
operating temperature*	-20°C ~ 60°C	●	●
operating humidity	10~95%RH non-condensing	●	●
operating pressure	80-120kPa	●	●
Structure			
body material	antistatic PC+TPU	●	●
weight	about 0.35kg	●	●
dimensions	156*74*54mm(H*W*D)	●	●
Certificates			
CPA	2016C106-32	●	●
EX	Exib II CT4 Gb	●	-
	Exdib II CT4 Gb	●	●

Note:* refers to there's some difference vary from different gas, please contact the manufacturer for details.



PORTABLE 4 GAS DETECTOR

The AGH6200 detector is a standard four-in-one gas detection alarm. The product can simultaneously detect the concentration of Ex, O₂, H₂S, CO. Automatic sound, light and vibration alarms.

The AGH6200F is a special designed flammable gas detector with CCCF certification, and can cope with the harsh environment of -40 °C to 70 °C.

Features

- Standard four gas with Ex, O₂, H₂S, CO is suitable for most gas detection applications.
- CCCF certification, suitable to -40°C ~ 70°C (AGH6200F only).
- Sound, light, vibration alarm method, effective warning.
- The TPU+PC housing, more wear-resistant.
- Ingressive protection in IP66 rating, dustproof and waterproof.
- Compatible with a sampling pump for confined space usage.

Dimensions

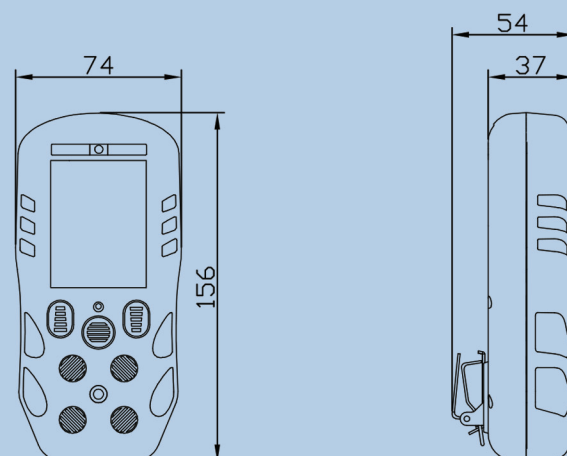

Specifications

Description	Specifications	AGH6200	AGH6200F
Function			
gas detected	Ex	●	●
	O2, CO, H2S	●	-
measure range	see QUICK-SELECTION-TABLE	●	●
response time*	T90≤60S	●	●
accuracy*	≤±5%F.S	●	●
repeatability*	≤2%F.S	●	●
sampling method	diffusion	●	●
Electric			
battery	rechargeable Li-battery 2200mAh	●	●
continuous operation	at least 18 hours after a typical 4 hours full charge	●	●
Alarm			
alarm method	sound,LED light,vibration	●	●
sound intensity	>90dB	●	●
Display and Operation			
display	LCD	●	●
button	2 (POWER, MENU)	●	●
Environment			
ingress protection	IP66	●	●
operating temperature*	-20℃~60℃	●	-
	-40℃~70℃	-	●
operating humidity	10~95%RH non-condensing	●	●
operating pressure	80-120kPa	●	●
Structure			
body material	antistatic PC+TPU	●	●
weight	about 0.28kg	●	●
dimensions	132*63*48mm(H*W*D)	●	●
Certificates			
CPA	2018CA0047-32	●	-
	2018CA0046-32	-	●
EX	Exdib II CT4 Gb	●	●
CCCF	073194850102ROM	-	●

Note:* refers to there's some difference vary from different gas, please contact the manufacturer for details.

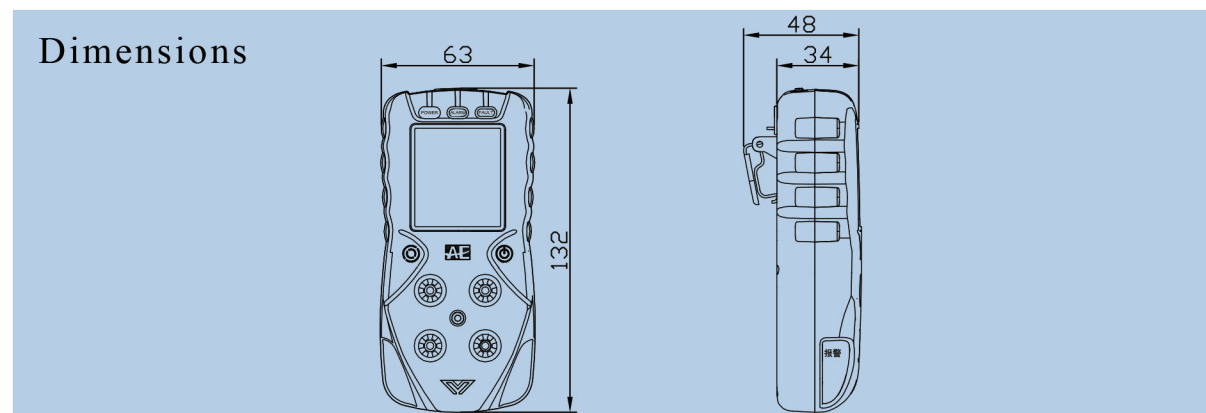

PORTABLE GAS LEAK DETECTOR

The AGH8100 & AGH8200 gas detector is designed to detect combustibe gas leakage. The product sensor is optimized for methane and LPG gas detection compared to conventional combustibe gas detectors, It can display μmol/mol (ppm) and is sensitive to small leakage in the environment. The product is IP66 rated, sturdy and durable.

The AGH8100 has a built-in sampling pump and quick response. AGH8200 is diffusion type

Features

- Special design for methane & LPG ppm level gas leak detection, and short warm-up time.
- The μmol/mol (ppm) level shows a sensitive reflection of traces of methane.
- Built-in pump makes the AGH8100 more sensitive and rapid, easy to use.
- Sound, light, vibration alarm method, effective warning.
- The TPU+PC housing, more wear-resistant.
- Ingressive protection in IP66 rating, dustproof and waterproof.

Specifications

Description	Specifications	AGH8100	AGH8200
Function			
gas detected	CH ₄ , LPG or other combustible gas	●	●
measure range	0-10000μmol/mol	●	●
response time	<5s	●	●
accuracy	≤±5%FS	●	●
detection principle	semiconductor	●	●
sampling method	built-in pump diffusion	● -	- ●
Electric			
battery	rechargeable Li-battery 2200mAh	●	●
continuous operation	over 8 hours	●	●
Alarm			
alarm method	sound, LED light, vibration	●	●
sound intensity	>90dB	●	●
Display and Operation			
display	OLED	●	●
button	3 (LEFT, OK, RIGHT)	●	●
Environment			
ingress protection	IP66	●	●
operating temp.*	-10°C ~ 55°C -40°C ~ 60°C	● -	- ●
operating humidity	≤93%RH 10%-95%RH non-condensing	● -	- ●
operating pressure	80-120kPa	●	●
Structure			
body material	PC+TPU	●	●
weight	about 0.34kg about 0.3kg	● -	- ●
dimensions	500*67*42mm(H*W*D) include probe	●	●
Certificates			
EX	Exdib II CT4 Gb	●	●

Dimensions

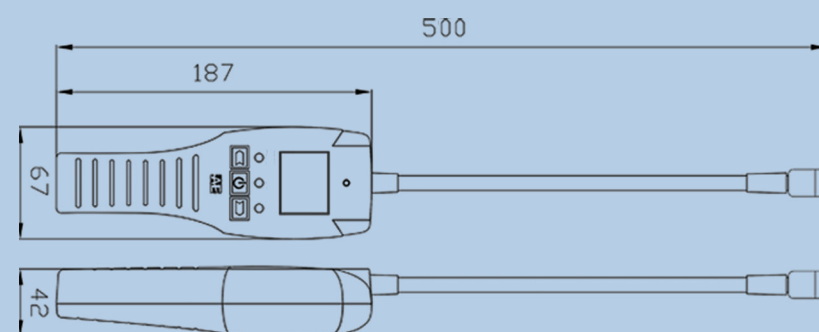

PORTABLE SAMPLING PUMP

The AGH1000B sampling pump is a hand-held gas sampling pump that is mainly used to assist the gas collection of portable gas detectors. With the intrinsically safe design, it can be used in explosive hazardous areas; large-capacity battery makes it a long operation time.

Features

- Compatible with the gas detector for confined space usage.
- A replaceable filter design that blocks dust, water to protect the gas detector.
- Blocking alarm function, effectively reminding the sampling blockage.
- Quick-plug connection design for a quick connection with the detector.
- Long stainless steel sampling probes are suitable for a variety of confined spaces.
- Intrinsically safe design for hazardous areas.

Specifications

Function	
sampling flow	500ml/min
indicator light	status, charge
Environment	
ingress protection	IP55
operating temperature	-10°C ~ 55°C
operating humidity	10~95%RH non-condensing
operating pressure	80-120kPa
Electrical	
battery	rechargeable lithium battery, 3.7V, 2200mAh
working time	≥12h
Structure	
body material	ABS
sampling pipe	stainless steel
weight	about 0.24kg
dimensions	410*35*38mm(H*W*D)
Certificate	
EX	Exib II CT4 Gb

Dimensions

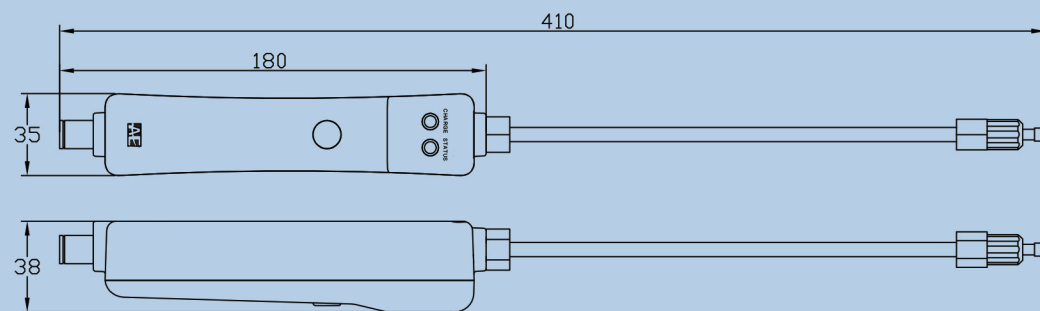

DUST MONITORING SYSTEM

Explosive dust will explode with an extremely strong destructive power when it encounters fire. Besides, dust particles have attracted much attention as a major indicator of environmental pollution.

The online dust monitoring system produced by AIYI Technologies can provide solutions for the above. The dust monitoring in pipelines and dust removal equipment to meet emission requirements. Besides, the system can also be used for the monitoring of explosive dust in workshops and warehouses. When the dust concentration in the environment exceeds the standard, the system will automatically alarm and exhaust.

The dust monitor adopts the laser backscattering principle to measure the dust concentration with high accuracy. And it is not affected by factors such as temperature and humidity. It is suitable for the harsh environment of wind, rain, high and low temperature for a long time.

■ DUST MONITORING IN PIPE/FLUE

Two main solutions: dust monitoring in pipe/flue, dust removal efficiency monitoring of dust removal equipment. The system is installed in the pipe/flue by the laser dust monitor through the flange, and it comes with 4-20mA/RS485 standard signal output, which can upload the real-time data to the terminal like DCS, PLC, IPC, etc.

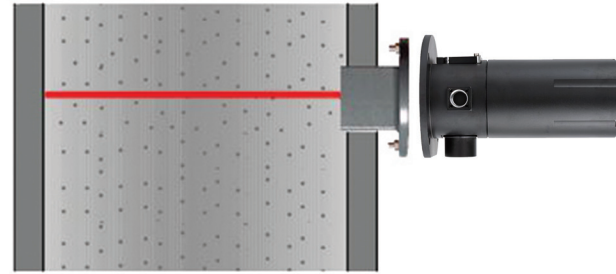

■ EXPLOSIVE DUST MONITORING

The explosive dust monitoring system can be used in the sites where there is an explosive hazard, to detect aluminum powder, zinc powder, various plastic powders, intermediates of organic synthetic drugs, wheat flour, sugar, wood chips, milk powder, tea powder, tobacco powder, plant fiber dust, etc.

According to the actual requirements, the dust monitor can be installed in the environment of the feeding process, conveyor belt, hoist, and other representative process points. When the dust exceeds the preset alarm value, the system will automatically perform various functions such as sound and light alarm, fan control etc.

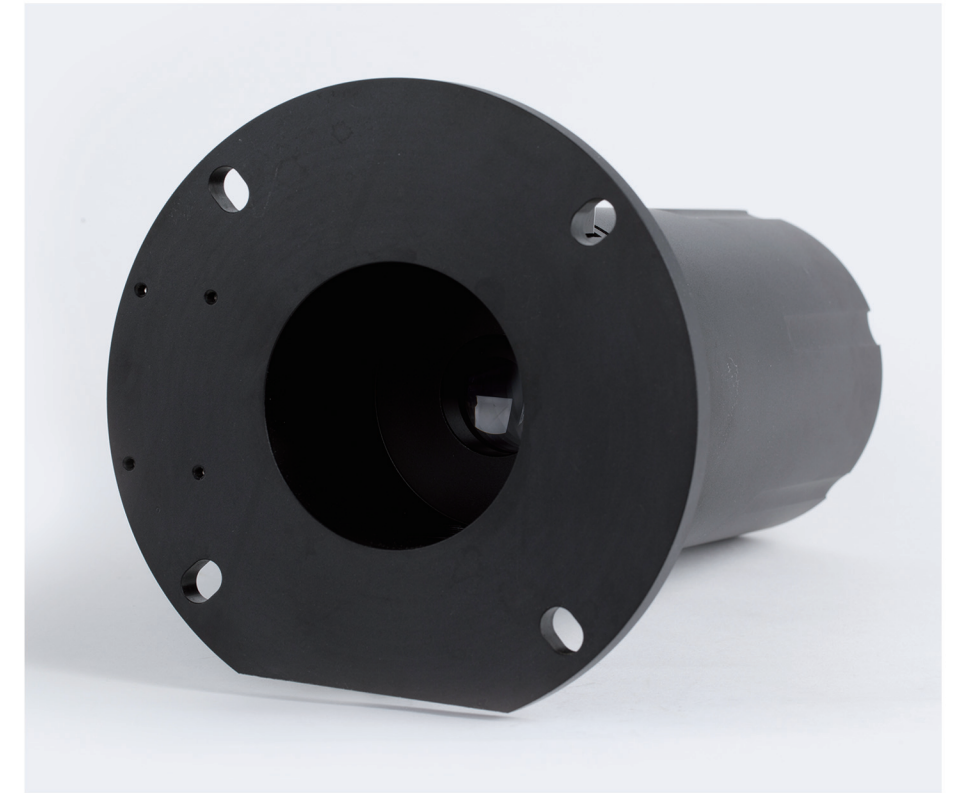
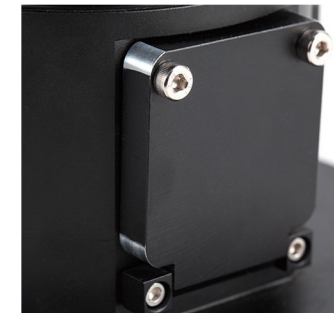
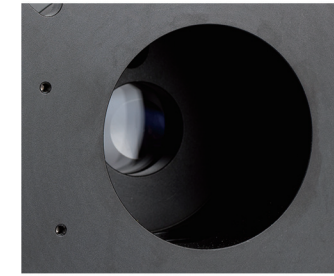
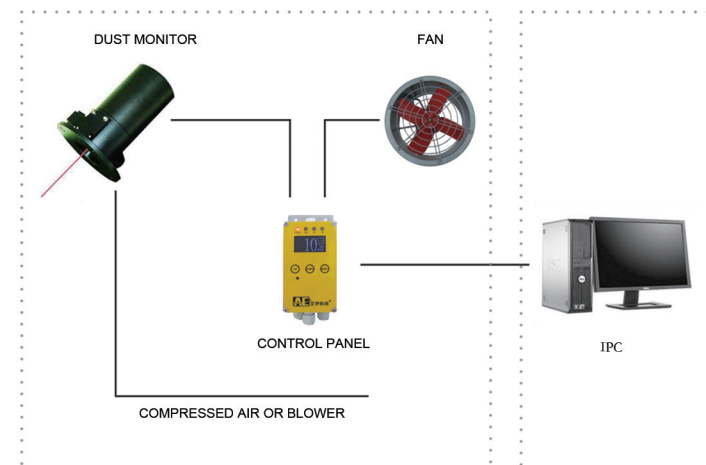

DUST MONITOR

The AGA series of online laser dust monitor adopts the principle of laser backscattering. The dust monitor irradiates the dust particles through the high-stability laser, and the irradiated particles reflect the laser signal. Based on the reflected signal intensity changes in proportion to the dust concentration, the reflected signal will be sensed by the embedded high-sensitivity laser receiver. In final, the dust concentration can be obtained by our micro-computer technology.

Features

- Laser backscattering and large dynamic adaptive phase-locking amplification technology make a real-time monitoring and a large measurement range.
- With the double certification of gas explosion-proof and dust explosion-proof (AGA6050 only), suitable to hazardous areas.
- The standard output signal can upload the dust concentration to the PLC, DCS, IPC etc.
- Ingressive protection in IP66 rating, dustproof and waterproof.
- Online calibration, no need to disassemble, easy to maintain.
- Compatible with the control panel and IPC etc.

Specifications

Description	Specifications	AGA6050	AGA6000
Dust detected			
workshop dust	particle size $\geq 5\mu\text{m}$	●	●
pipeline dust	particle size $\geq 5\mu\text{m}$	●	●
Function			
detection principle	laser backscattering	●	●
wavelength	(650±20)nm successive wave power density $< 5\text{mW/m}^2$	●	●
measure range	0-100/500/1000/4000 mg/m^3	●	●
response time	$\leq 10\text{s}$	●	●
drift	$\leq 2\%\text{F.S}$	●	●
space range	0.7-5m (in environment)	●	●
	0.7-20m (in pipe)	●	●
Electric			
power supply	24VDC	●	●
power consumption	$\leq 2.5\text{W}$	●	●
signal output	4-20mA	●	●
	RS485	●	●
signal input	RPG-2200 safety barrier is required, 12V, 50mA	●	●
Environment			
ingress protection	IP65	●	●
operating temperature	-20°C ~ 50°C	●	●
operating humidity	10~95%RH non-condensing	●	●
operating pressure	80-120kPa	●	●
Structure			
body material	aluminum alloy	●	●
weight	about 2.8kg	●	●
dimensions	235*160*160mm(H*W*D)	●	●
Certificates			
EX	Exib II BT4 Gb	●	-
	ExibD21T130°C Gb	●	-
SIL	SIL2	●	●

Dimensions

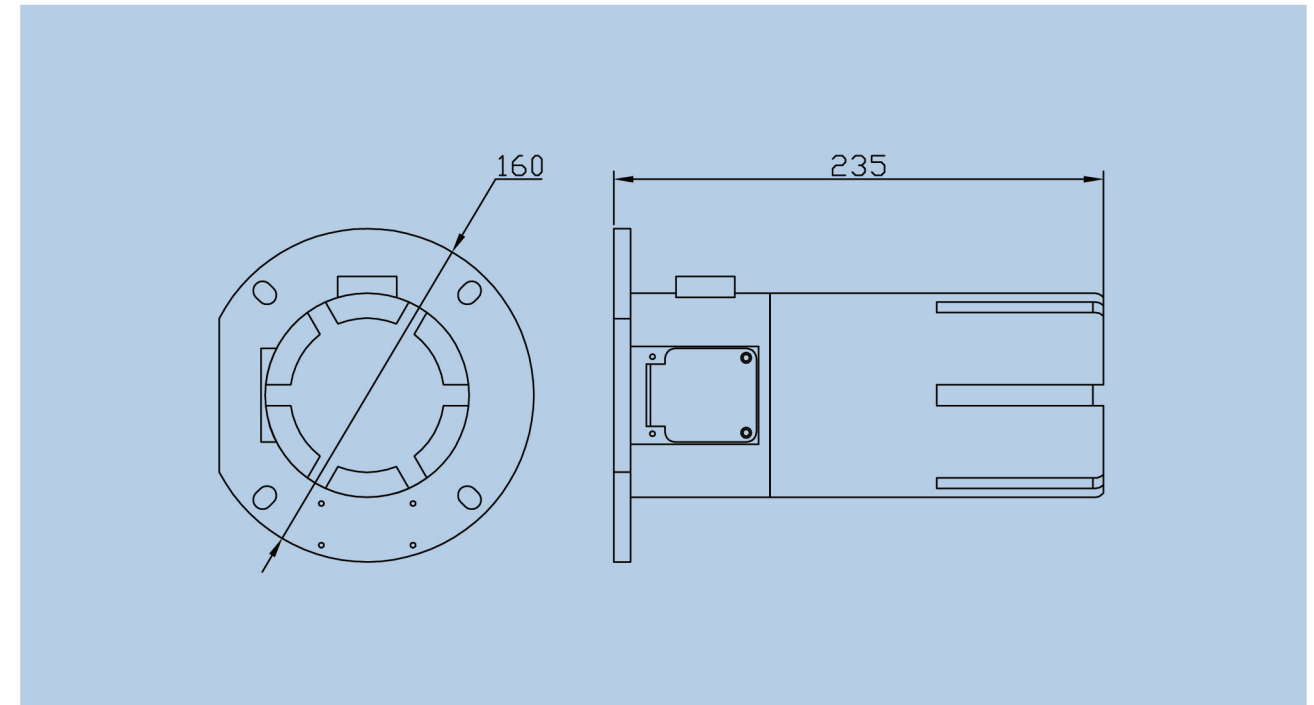

Wiring

