

Pyxis[®]

SP-200 OXIPOCKET™ Handheld User Manual



Water Professionals Deserve Better Tools.
www.pyxis-lab.com

SP-200 Handheld Colorimetric Analyzer User Manual

February 8, 2021
Rev. 1.02

Pyxis Lab, Inc.
1729 Majestic Dr. Suite 5
Lafayette, CO 80026 USA
www.pyxis-lab.com

Table of Contents

1	Introduction	3
1.1	Main Features	3
2	Specifications	3
3	Unpacking Instrument	3
3.1	Standard Accessories	4
3.2	Optional Accessories	4
4	Installation	5
4.1	Battery Installation	5
5	Instrument Overview	6
5.1	Control Keys	6
5.2	Main Module On/Off	6
6	Measurement	7
6.1	Colorimetric Methods	7
6.2	Select a Method	7
6.3	Single-Vial Measurement	8
7	Calibration	9
7.1	Set Method Parameters	9
7.2	Low Calibration	10
7.3	Slope Calibration	11
7.4	Restore Factory Default Values	12
8	Device Information and Diagnosis	13
8.1	Bluetooth Connection to Devices	13
8.2	Factory Reset	14
9	Use with uPyxis® Mobile App	15
9.1	Download uPyxis® Mobile App	15
9.2	Connecting to uPyxis® Mobile App	16
9.3	Setting Screen	17
9.4	System Screen	18
9.5	Datalog Screen	19
10	Use with uPyxis® Desktop App	19
10.1	Install uPyxis® Desktop App	19
10.2	Connecting to uPyxis® Desktop App	20
10.3	System Screen	21
10.4	Setting Screen	22
10.5	Datalog Screen	22

11 Device Maintenance and Precaution	23
11.1 Maintenance Best Practices and Quick Tips	23
11.2 Storage	23
12 Contact Us	23

Warranty Information

Confidentiality

The information contained in this manual may be confidential and proprietary and is the property of Pyxis Lab, Inc. Information disclosed herein shall not be used to manufacture, construct, or otherwise reproduce the goods described. Information disclosed herein shall not be disclosed to others or made public in any manner without the express written consent of Pyxis Lab, Inc.

Standard Limited Warranty

Pyxis Lab warrants its products for defects in materials and workmanship. Pyxis Lab will, at its option, repair or replace instrument components that prove to be defective with new or remanufactured components (i.e., equivalent to new). The warranty set forth is exclusive and no other warranty, whether written or oral, is expressed or implied.

Warranty Term

The Pyxis warranty term is thirteen (13) months ex-works. In no event shall the standard limited warranty coverage extend beyond thirteen (13) months from original shipment date.

Warranty Service

Damaged or dysfunctional instruments may be returned to Pyxis for repair or replacement. In some instances, replacement instruments may be available for short duration loan or lease.

Pyxis warrants that any labor services provided shall conform to the reasonable standards of technical competency and performance effective at the time of delivery. All service interventions are to be reviewed and authorized as correct and complete at the completion of the service by a customer representative, or designate. Pyxis warrants these services for 30 days after the authorization and will correct any qualifying deficiency in labor provided that the labor service deficiency is exactly related to the originating event. No other remedy, other than the provision of labor services, may be applicable.

Repair components (parts and materials), but not consumables, provided during a repair, or purchased individually, are warranted for 90 days ex-works for materials and workmanship. In no event will the incorporation of a warranted repair component into an instrument extend the whole instrument's warranty beyond its original term.

Warranty Shipping

A Repair Authorization (RA) Number must be obtained from Pyxis Technical Support before any product can be returned to the factory. Pyxis will pay freight charges to ship replacement or repaired products to the customer. The customer shall pay freight charges for returning products to Pyxis. Any product returned to the factory without an RA number will be returned to the customer. To receive an RMA you can generate a request on our website at <https://pyxis-lab.com/request-tech-support/>.

Pyxis Technical Support

Contact Pyxis Technical Support at +1 (866) 203-8397, service@pyxis-lab.com, or by filling out a request for support at <https://pyxis-lab.com/request-tech-support/>.

1 Introduction

The Pyxis SP-200 Handheld Colorimetric Analyzer is a single- and multi-parameter colorimetric testing platform. With the use of auxiliary colorimetric reagent kits, the SP-200 can quickly test a variety of water quality parameters on the spot with high sensitivity.

1.1 Main Features

The SP-200 includes the following features:

- Innovative technology platform with colorimetric measurement of 6 LED wavelengths
- Use of matching reagent kits and prefabricated reagent tubes
- Long standby mainframe 10,000+ measurements
- Can store up to 8 GB of test data (including test time)
- Create user-defined standard curves, view historical data, or analyze data via the **uPyxis®** App.

2 Specifications

Table 1. SP-200 Specifications

Item	Specification*
Part Number (P/N)	50802
Absorbance Linearity Range	0–2.0 Abs
Absorbance Reproducibility	±0.005 Abs (0–1.0 Abs)
Colorimeter Wavelength	365/420/470/525/568/624 nm
Wavelength Accuracy	±1 nm
Temperature Range	40–106 °F (4–41 °C)
Humidity	85% at 106 °F (41 °C)
Data Storage	30,000 group data storage, Bluetooth transmission
Display	320x240 TFT-LCD, visible under direct sunlight
Power Supply	4 AA alkaline batteries
Typical Battery Life	10,000 readings
Cuvette	24mm diameter cuvette
Dimension (L × W × H)	6.69 × 3.15 × 1.77 inch (170 × 80 × 45 mm)
Weight [†]	0.88 lbs (400 g)
Enclosure Rating	IP67
Regulation	CE/RoHS

* With Pyxis's continuous improvement policy, these specifications are subject to change without notice.

[†] Batteries excluded

3 Unpacking Instrument

Remove the instrument and accessories from the shipping container and inspect each item for any damage that may have occurred during shipment. Verify that all items listed on the packing slip are included. If any items are missing or damaged, please contact Pyxis Customer Service at service@pyxislab.com.

3.1 Standard Accessories

- Quick-Start Guide
- Four (4) AA alkaline batteries
- Two (2) 10 mL Sample Vials, 24 mm diameter P/N: MA-24
- Bluetooth/USB Adapter for Desktop P/N: MA-NEB
- User Manual available online at <https://pyxis-lab.com/support/>

3.2 Optional Accessories

The following optional accessories can be ordered from Pyxis Customer Service (order@pyxis-lab.com) or Pyxis E-Store at <https://pyxis-lab.com/shop/>.

Table 2. Optional Accessories

Accessory Name	Part Number (P/N)
Pyxis Carrying Case for Handheld Devices	50725
10 mL Sample Vial	MA-24
25 mL Sample Vial	MA-25

4 Installation

4.1 Battery Installation

The SP-200 is powered by four alkaline batteries. Typical battery life lasts for 10,000 measurements or 10 months. When the battery capacity is critically low, the SP-200 will display a "LOW BATTERY" warning for 5 seconds and then automatically turn off.

NOTE Do not use rechargeable nickel cadmium (NiCad) or lithium batteries.

Replace the batteries to resume operation of the SP-200 after the battery warning. The SP-200 will automatically turn on in the measurement mode after new batteries are installation.

The SP-200 battery compartment, shown in Figure ??, is on the back side of the instrument. Batteries are held in place by a cover secured with two Phillips-head screws.

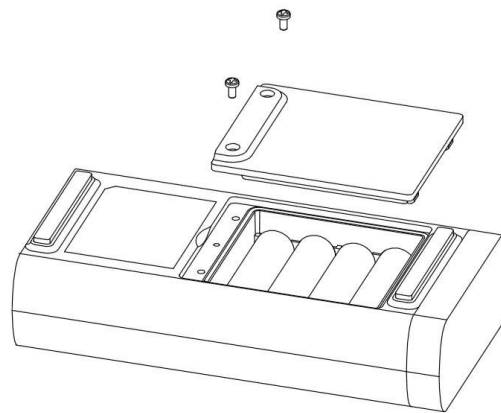

Figure 1. The SP-200 battery compartment

Install batteries using the following steps:

1. Remove the battery compartment cover by loosening the two screws.
2. Remove old batteries and dispose of them properly.
3. Following the positive and negative terminal signs in the compartment bottom, snap four new AA alkaline batteries firmly into the battery holder.
4. Replace the battery compartment cover and ensure that the sealing O-ring is lying flat on the battery holder.
5. Fasten the two screws.

NOTE Failure to properly seat the O-ring may result in water damage to the SP-200.

5 Instrument Overview

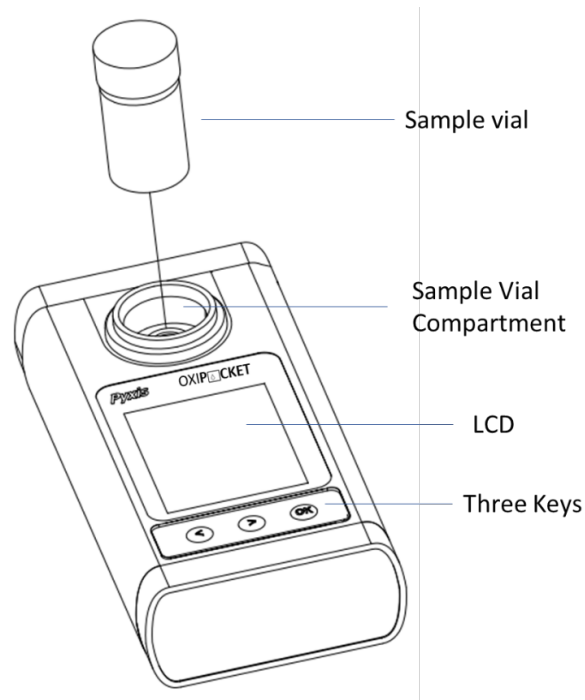







Figure 2.

5.1 Control Keys

The SP-200 has three control keys, as shown in Figure 2. The left (), right (), and ok () keys are used to launch actions indicated on the LCD display directly above the keys. The labels above the keys indicate the function associated with each key and functions can be changed in different operation modes.

5.2 Main Module On/Off

To turn on the SP-200: Press  momentarily and release.

To turn off the SP-200: Press and hold  for about three seconds. Release  when the LCD display turns off. The SP-200 turns itself off after 60 seconds without user interaction detected. This is done to conserve battery life.

NOTE This auto-time off setting may be customized by the user as desired through the *uPyxis® Mobile or Desktop App*.

6 Measurement

6.1 Colorimetric Methods

A wide range of colorimetric methods is supported by the SP-200 analyzer and the number of them keeps increasing with continuous development of Pyxis. The following table is list of Supported Colorimetric Methods:

Table 3. Supported Colorimetric Methods

Abbreviation	Chemical Measured	Method Type	Range
CL-F	Free Chlorine	DPD	2.2 ppm
CL-T	Total Chlorine	DPD	2.2 ppm
Br-T	Total Bromine	DPD	4.5 ppm
CLO2	Chlorine Dioxide	DPD	5.0 ppm
PAA	Peroxyacetic	Iodometry	500 ppm
H2O2	Hydrogen Peroxide	Iodometry	500 ppm
Bleach-L	Bleach — Low Range	Direct Read	1.0%
Bleach-H	Bleach — High Range	Direct Read	16.0%
O3	Ozone	DPD	1.0 ppm
NH2C	Chloramine, Mono — Low Range	Indophenol	3.0 ppm
CLO2D	Chlorine Dioxide — Mid Range	Direct Read	50 ppm
CLO2H	Chlorine Dioxide — High Range	Direct Read	1500 ppm
CL2H	Free/Total Chlorine — High Range	DPD	10 ppm
CL2UH	Free/Total Chlorine — Ultra High Range	Iodometry	400 ppm

6.2 Select a Method

When powered on, the SP-200 is in the screen of the last selected measurement method, as shown in the Figure 3. Use the following steps to select a different method:

1. Press **Color** () to launch the **Method** screen (Figure 4).

**NOTE* The top line of the page shows the most frequently selected method, marked by the ☆.*

2. Press **Up** () and **Down** () to navigate to the desired method.

**NOTE* Long press  to exit without changing the method.*

3. Press  to select and start the highlighted method.

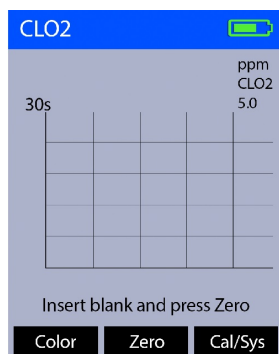

Figure 3.

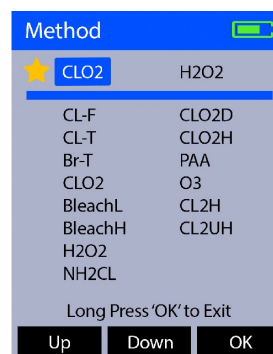





Figure 4.

6.3 Single-Vial Measurement

1. Make the Blank sample by filling a sample vial with the water sample and place it in the sample vial compartment of the SP-200.
2. Press **Zero** (). **Zero** will then appear on the top-left corner of the display (Figure 5).
3. Add the appropriate reagent to the Blank sample.
4. Make the Developed sample by capping the sample vial and inverting several times to fully mix the reagent and sample.
5. Place the Developed sample in the sample vial compartment SP-200.
6. Press **TMR1** () to start the method timer (Figure 6).
7. The SP-200 will continuously display the concentration as the timer counts down. Record the final value after timer stops (Figure 7).

NOTE The rate of the reaction is often faster than the standard preset time. If the concentration remains stable on the concentration-time plot, press **Stop** () to terminate the timing step early. The last concentration measurement will be displayed.

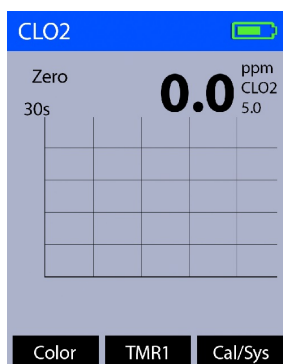

Figure 5.

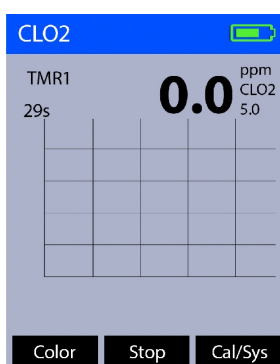

Figure 6.

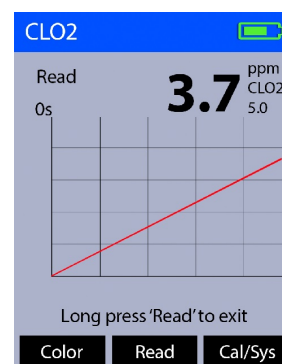

Figure 7.

7 Calibration

7.1 Set Method Parameters

Each method has two parameters that can be changed by the user; the units and the chemical formula form. To change these parameters for a given method, use the following steps:

1. Complete a measurement with the desired method.
2. Press **Cal/Sys** (OK) as needed to highlight either **Unit** or **Form**.
3. Press **OK** (>) to launch the **Choose Unit** screen (Figure 8) or the **Choose Form** screen (Figure 9).
4. Press » (OK) to navigate to the desired parameter option.
5. Press **OK** (>) to select the desired parameter option.

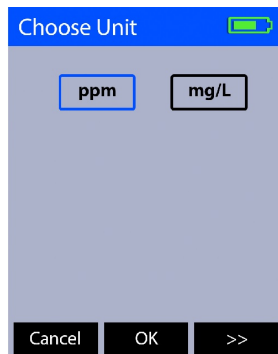

Figure 8.

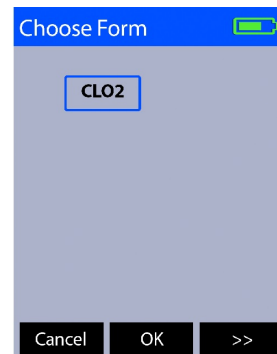









Figure 9.

7.2 Low Calibration

Some methods have a non-zero intercept value in the calibration equation. For these methods, the appropriate non-zero intercept value is shipped pre-loaded in the SP-200. The following steps are used to carry out a low calibration which changes this non-zero intercept value:

1. Complete a measurement with the desired method.
2. Press **Cal/Sys** () as needed to highlight **Low-C**.
3. Press **OK** () to launch the calibration screen (Figure 10).
4. Fill a sample vial with deionized (DI) water or with solution with a known concentration and place it in the sample vial compartment of the SP-200.
NOTE* For best results, the know concentration should be less than half of the maximum concentration of the method. See the **Supported Colorimetric Methods table for concentration ranges for each method.*
5. Use « () and ≈ () to adjust the concentration value to match the known concentration of the solution or to zero if using deionized (DI) water.
6. Press **Calib** () to continue with the entered concentration value. The display updates as shown in Figure 11.
7. Press **OK** () to start the low calibration.
8. The message “Low point calibration succeeded” will appear on the display (Figure 12).
9. Press  to exit.

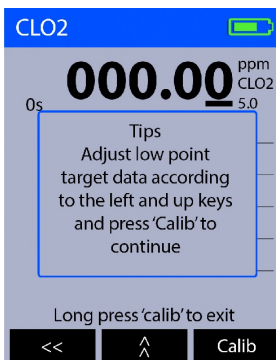

Figure 10.

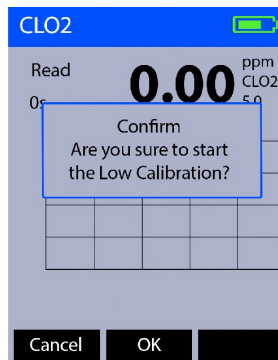

Figure 11.

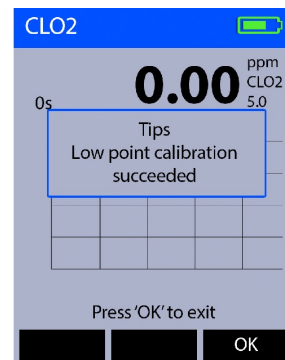









Figure 12.

7.3 Slope Calibration

Each method has been calibrated prior to shipping, there is no need to calibrate unless a calibration check indicates that the method needs a calibration. The following steps are used to carry out a slope calibration:

1. Complete a measurement with the desired method.
2. Press **Cal/Sys** () as needed to highlight **Slope-C**.
3. Press **OK** () to launch the calibration screen (Figure 13).
4. Fill a sample vial with a solution with known concentration and place it in the sample vial compartment of the SP-200.
NOTE* For best results, the know concentration should be less maximum concentration of the method. See the **Supported Colorimetric Methods table for concentration ranges for each method.*
5. Use « () and ≈ () to adjust the concentration value to match the known concentration of the solution.
6. Press **Calib** () to continue with the entered concentration value. The display updates as shown in Figure 14.
7. Press **OK** () to start the slope calibration.
8. The message “High point calibration succeeded” will appear on the display (Figure 15).
9. Press  to exit.

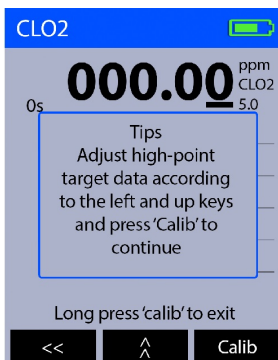

Figure 13.

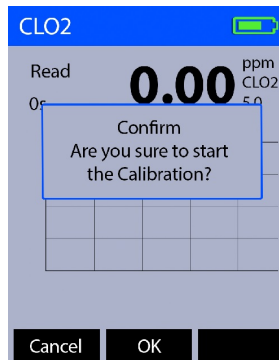

Figure 14.

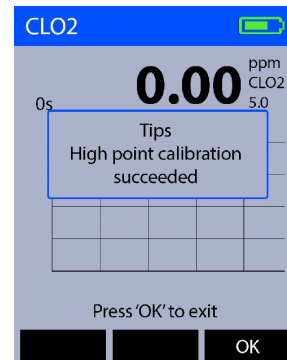





Figure 15.

7.4 Restore Factory Default Values

Each method can be restored to the factory default intercept and slope values, individually. The following steps are used to carry out a factory default of the desired method's intercept and slope values:

1. Complete a measurement with the desired method.
2. Press **Cal/Sys** () as needed to highlight **Default**.
3. Press **OK** (). The display updates as shown in Figure 16.
4. Press **OK** () to start the factory default of the desired method.
5. The message "**Restore data succeeded**" will appear on the display (Figure 17).

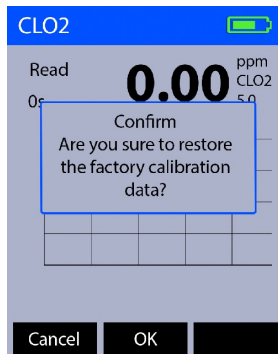

Figure 16.

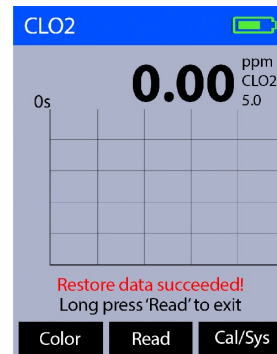



Figure 17.

8 Device Information and Diagnosis

The **Information** screen is launched when **Cal/Sys** () is pressed while not in an ongoing measurement procedure. This screen contains the device serial number, software version, and hardware version (Figure 18). The battery life as a percentage and the MAC addresses for main module also shown.

Press **Diag** () to launch the **Diagnosis** screen where raw measurement data are displayed (Figure 19). The information has no use for normal operation, but instead is used for device troubleshooting. Provide an image of both the **Information** screen and the **Diagnosis** screen when you contact Pyxis (service@pyxis-lab.com) for troubleshooting your device or call +1 (866) 203-8397.

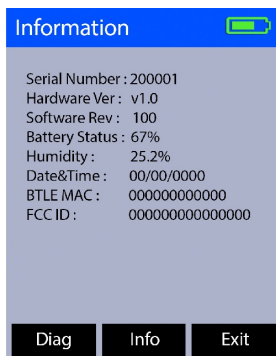

Figure 18.

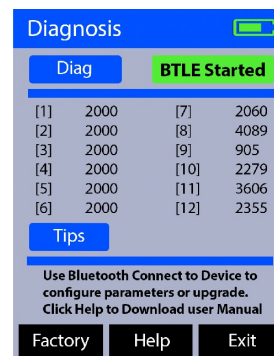





Figure 19.

8.1 Bluetooth Connection to Devices

The SP-200 uses a built-in Bluetooth Low Energy Connection (BTLE) to connect wirelessly to a smart phone via the **uPyxis**® Mobile App or to a computer via the included Bluetooth Adapter (P/N: MA-NEB) and the **uPyxis**® Desktop App. To allow the SP-200 to connect via Bluetooth with other devices follow the steps below:

1. Power on the SP-200 by pressing .
2. Press **Cal/Sys** () to launch the **Information** screen.
3. Press **Diag** () to launch the **Diagnosis** screen.
4. Allow 5–10 seconds for the message in the top-right corner of the display change from **Starting BTLE...** to **BTLE Started** (Figure 19).
5. Choose to connect via one of two options:
 - (a) The **uPyxis**® Mobile App (see the **Use with uPyxis**® **Mobile App** section), or
 - (b) The **uPyxis**® Desktop App (see the **Use with uPyxis**® **Desktop App** section).

8.2 Factory Reset

Use the following steps to restore all device parameters to factory default:

1. Power on the SP-200 by pressing **OK**.
2. Press **Cal/Sys** (**OK**) to launch the **Information** screen.
3. Press **Diag** (**<**) to launch the **Diagnosis** screen.
4. Allow 5–10 seconds for the message in the top-right corner of the display change from **Starting BTLE...** to **BTLE Started**.
5. Press **Factory** (**<**). The display updates as shown in Figure 20.
6. Press **OK** (**>**) to start the factory reset.
7. The message “Data recovery is successful!” will appear on the display (Figure 21).

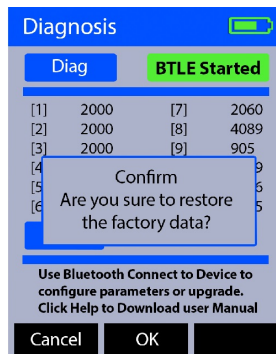

Figure 20.

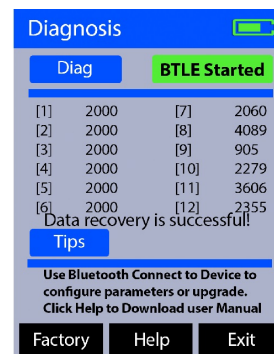

Figure 21.

9 Use with uPyxis® Mobile App

9.1 Download uPyxis® Mobile App

Download uPyxis® Mobile App from [Apple App Store](#) or [Google Play](#).



Figure 22. uPyxis® Mobile App installation

9.2 Connecting to uPyxis® Mobile App

Connect the SP-200 sensor to a mobile smart phone according to the following steps:

1. Follow the steps in the **Bluetooth Connection to Devices** section to make the SP-200 discoverable.
2. Open **uPyxis®** Mobile App.
3. On **uPyxis®** Mobile App, pull down to refresh the list of available Pyxis devices.
4. If the connection is successful, the SP-200 and its Serial Number (SN) will be displayed (Figure 26).
5. Press on the **SP-200 image**.



Figure 23.

9.3 Setting Screen

From the **Setting** screen, the user can set the **Power off time** and **Screen off time** in seconds.

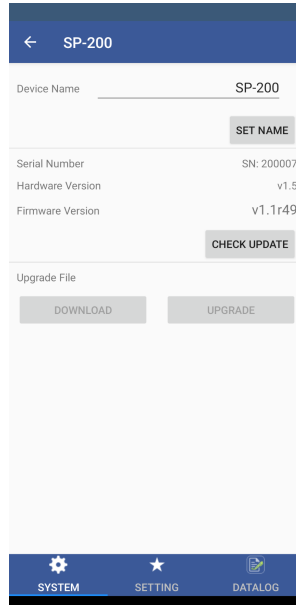

Figure 24.

9.4 System Screen

When connected, the uPyxis® Mobile App will default to the **System** screen. From the **System** screen, users can change the **Device Name**, find the **Serial Number**, **Hardware Version**, and **Firmware Version**, as well as update the firmware of the SP-200 by pressing **Check Update**. If a firmware update is available, press **Get Firmware**. Once the new firmware is downloaded, press **Upgrade Firmware**.

NOTE *The firmware update process takes some time and will require the SP-200 to stay within range (approximately 10 ft without obstructions) for the entire duration of the update.*

Once the update is complete, the SP-200 will reboot which will disconnect the SP-200 from the uPyxis® Mobile App.

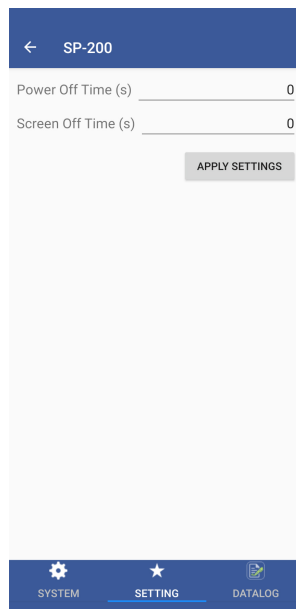

Figure 25.

9.5 Datalog Screen

From the **Datalog** screen, the user can view and export the internal log files of the SP-200 by pressing **Read Datalogs** and selecting the desired datalog (these are separated by month). The SP-200 will then populate any relevant log event from the selected datalog which can be viewed in more detail by pressing **Read Record** or exported as a CSV document by pressing **Export/Share**.

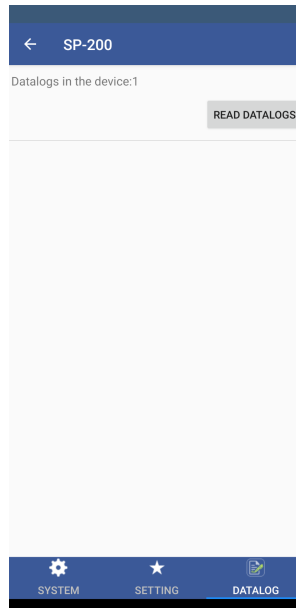

Figure 26.

10 Use with uPyxis® Desktop App

10.1 Install uPyxis® Desktop App

Download the latest version of **uPyxis®** Desktop software package from: <https://pyxis-lab.com/upyxis/> this setup package will download and install the Microsoft.Net Framework 4.5 (if not previously installed on the PC), the USB driver for the USB-Bluetooth adapter (MA-NEB), the USB-RS485 adapter (MA-485), and the main **uPyxis®** Desktop application. Double click the **uPyxis.Setup.exe** file to install.

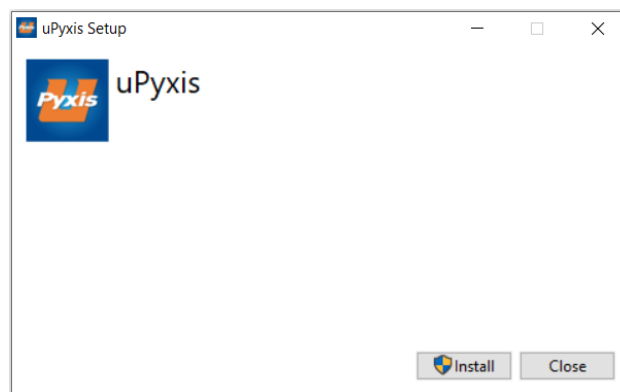

Figure 27. uPyxis® Desktop App installation

Click **Install** to start the installation process. Follow the screen instructions to complete the USB driver and uPyxis installation.

10.2 Connecting to uPyxis® Desktop App

Connect the SP-200 to a Windows computer using a Bluetooth/USB adapter (P/N: MA-NEB) according to the following steps:

1. Follow the steps in the **Bluetooth Connection to Devices** section to make the SP-200 discoverable.
2. Plug the Bluetooth/USB adapter into a USB port in the computer.
3. Launch **uPyxis®** Desktop App.
4. On **uPyxis®** Desktop App, click Device → **Connect via USB-Bluetooth** (Figure 30).
5. If the connection is successful, the SP-200 and its Serial Number (SN) will be displayed in the left pane of the **uPyxis®** window.

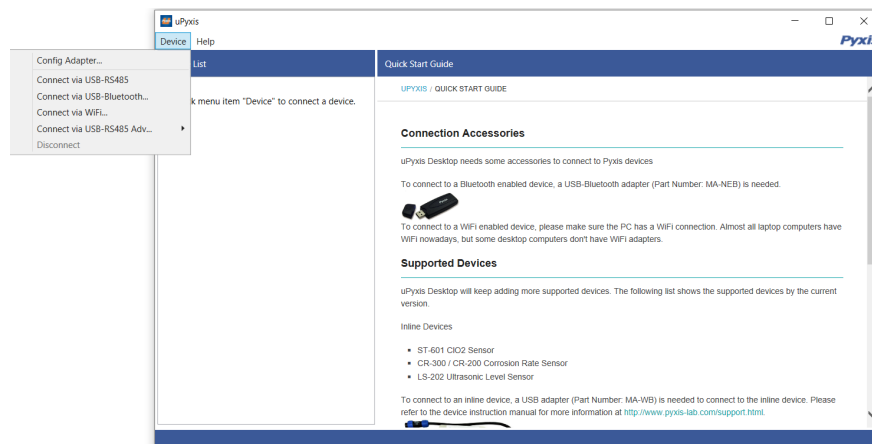

Figure 28.

10.3 System Screen

Once connected to the device, a picture of the device will appear on the top-left corner of the window and the **uPyxis**® Desktop App will default to the **System** screen. From the **System** screen, users can upgrade the firmware by selecting an appropriate firmware file (contact service@pyxis-lab.com for these firmware files) and clicking **Upgrade Firmware**.

NOTE *The firmware update process takes some time and will require the SP-200 to stay within range (approximately 10 ft without obstructions) for the entire duration of the update.*

Once the update is complete, the SP-200 will reboot which will disconnect the SP-200 from the **uPyxis**® Mobile App.

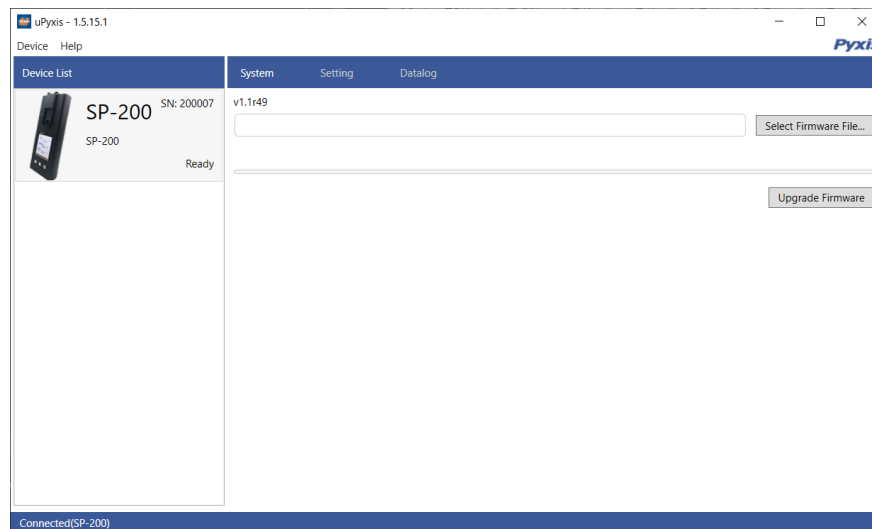

Figure 29.

10.4 Setting Screen

From the **Setting** screen, the user can set the **Power off time** and **Screen off time** in seconds.

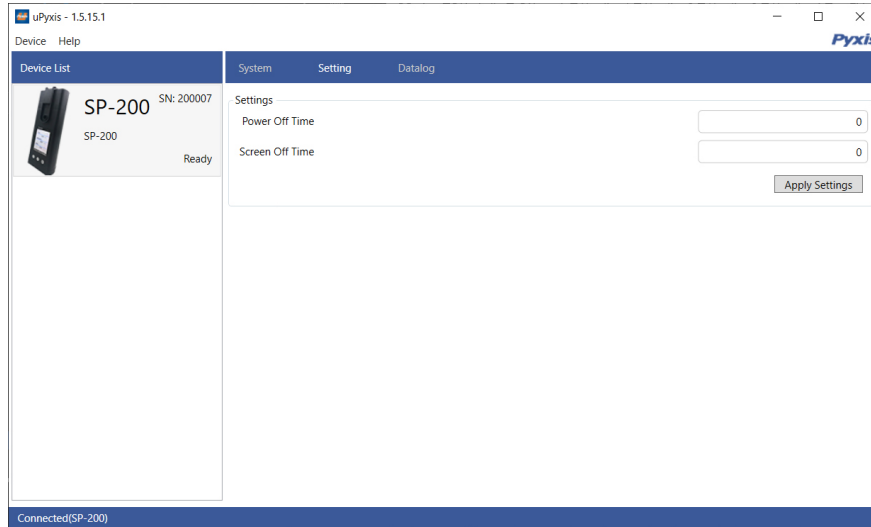

Figure 30.

10.5 Datalog Screen

From the **Datalog** screen, the user can view, delete, and export the internal log files of the SP-200 by clicking **Read Datalog List** and selecting the desired datalog (these are separated by month). The SP-200 will then populate any relevant log event from the selected datalog which can be viewed in more detail by clicking **Read Datalog**, deleted by clicking **Delete**, or exported by clicking **Export as .CSV File**.

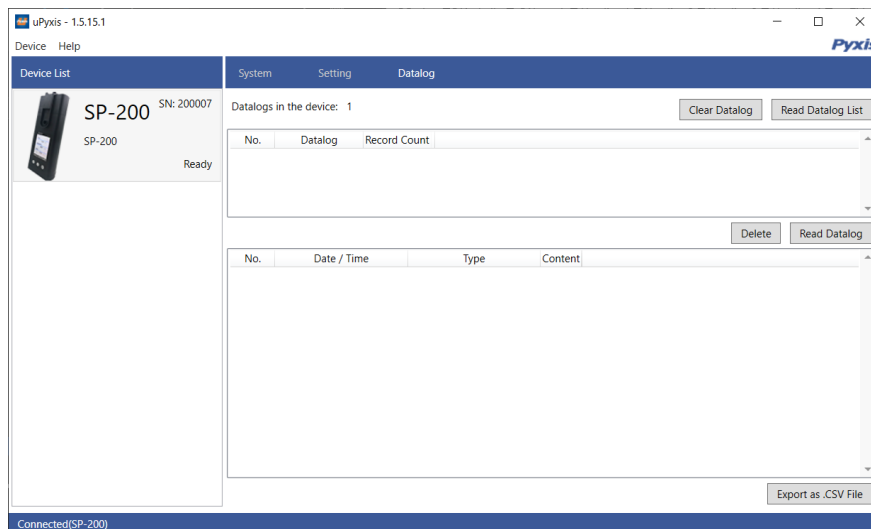

Figure 31.

11 Device Maintenance and Precaution

11.1 Maintenance Best Practices and Quick Tips

For greatly increased working life and ease of use of the SP-200 follow the list of maintenance best practices and quick tips below:

- Use a soft cloth or lint free paper tissue to clean the sample vial compartment periodically. Remove debris, scale, and deposit promptly.
- Although the SP-200 is protected from water damage, it is a good practice to avoid water entering the sample vial compartment. Deposits left behind when the water is evaporated could affect performance.
- During storage and transportation, do not leave a sample vial in the sample vial compartment.
- Replace batteries when the SP-200 displays a warning message indicating LOW BATTERY voltage. Remove batteries from the SP-200 battery compartment if the SP-200 is going to be placed in storage for a long period time.
- When the SP-200 is shipped, a desiccant pack is included in the desiccant compartment underneath the cover of the battery compartment. It is recommended that a new desiccant pack is replaced each time the batteries are replaced.

11.2 Storage

The SP-200 should be stored in the temperature range of 0–140 °F (-18–60 °C) and relative humidity less than 85% at 106 °F (41 °C). Do not leave the SP-200 in a parked vehicle as the temperature inside can reach above 150 °F in summer and -20 °F in winter. Remove batteries from the SP-200 battery compartment when in storage for a long period time. Do not leave a sample vial in the sample vial compartment.

12 Contact Us

Pyxis Lab, Inc

1729 Majestic Dr. Suite 5

Lafayette, CO 80026 USA

www.pyxis-lab.com

Phone: +1 (866) 203-8397

Email: service@pyxis-lab.com