

INSTRUCTION MANUAL

TECO INVERTER



TECO INVERTER S510 Series

S510 manual

Table of Contents

Chapter 0	Preface	0-1
	0.1 Preface.....	0-1
Chapter 1	Safety Precautions	1-1
	1.1 Before Power UP.....	1-1
	1.2 During Power UP.....	1-1
	1.3 Before Operation.....	1-2
	1.4 During Operation.....	1-2
	1.5 Inverter Disposal.....	1-2
	1.6 Guaranteed Liability Exemption.....	1-3
Chapter 2	Part Number Definition	2-1
	2.1 Model Part Number.....	2-1
	2.2 Standard Product Specification.....	2-2
Chapter 3	Environment & Installation	3-1
	3.1 Environment.....	3-1
	3.2 Installation.....	3-4
	3.2.1 Installation methods.....	3-4
	3.2.2 Installation space.....	3-7
	3.2.3 De-rating curve.....	3-8
	3.2.4 Capacitor reforming Guide after long storage.....	3-8
	3.3 Wiring guidelines.....	3-9
	3.3.1 Main Considerations.....	3-9
	3.3.2 Power cables.....	3-10
	3.3.3 Control cable selection and wiring.....	3-10
	3.3.4 Wiring and EMC guidelines.....	3-11
	3.3.5 Failure liability.....	3-12
	3.3.6 Considerations for peripheral equipment.....	3-13
	3.3.7 Ground connection.....	3-14
	3.4 Specifications.....	3-15
	3.4.1 Product Specifications.....	3-15
	3.4.2 General Specifications.....	3-16
	3.5 Standard wiring.....	3-18
	3.6 Terminal Description.....	3-19
	3.6.1 Description of main circuit terminals.....	3-19
	3.6.2 Description of control circuit terminals.....	3-20
	3.7 Outline Dimensions.....	3-21
	3.8 EMC filter Disconnection.....	3-23
	3.9 Keypad installation.....	3-24
Chapter 4	Software Index	4-1
	4.1 Keypad Description	4-1
	4.1.1 Operator Panel Functions.....	4-1

	4.1.2 Digital Display Description.....	4-2
	4.1.3 Digital Display Setup.....	4-4
	4.1.4 Example of Keypad Operation	4-6
	4.1.5 Operation Control.....	4-8
	4.2 Programmable Parameter Groups.....	4-9
	4.3 Parameter Function Description.....	4-28
Chapter 5	Troubleshooting and Maintenance.....	5-1
	5.1 Error Display and Corrective Action.....	5-1
	5.1.1 Manual Reset and Auto-Reset.....	5-1
	5.1.2 Keypad Operation Error Instruction.....	5-4
	5.1.3 Special conditions.....	5-5
	5.1.4 No Keypad Model Error Code Instruction.....	5-5
	5.2 General troubleshooting.....	5-6
	5.3 Troubleshooting of the inverter.....	5-7
	5.3.1 Quick troubleshooting of the inverter.....	5-7
	5.3.2 Troubleshooting for OC, OL error displays.....	5-9
	5.3.3 Troubleshooting for OV, LV error.....	5-10
	5.3.4 The Motor can not run.....	5-11
	5.3.5 Motor Overheating.....	5-12
	5.3.6 Motor runs unbalanced.....	5-13
	5.4 Routine and periodic inspection.....	5-14
	5.5 Maintenance.....	5-15
Chapter 6	Peripheral Components.....	6-1
	6.1 Reactor Specifications.....	6-1
	6.2 Electromagnetic Contactor & No fuse circuit breaker.....	6-1
	6.3 Fuse Specification.....	6-1
	6.4 Fuse Specification(UL Model Recommended).....	6-1
	6.5 Braking Resistor.....	6-2
	6.6 Copy Unit(JN5-CU).....	6-2
	6.7 Communication option.....	6-3
	6.8 RJ45 to USB connecting Cable (1.8m).....	6-3
Appendix 1	S510 Parameters Setting List.....	App1-1
Appendix 2	Instructions for UL.....	App2-1
Appendix 3	S510 Communication protocol.....	App3-1
Appendix 4	JN5-CM-USB instruction manual.....	App4-1
Appendix 5	S510 accessories	App5-1

Chapter 0 Preface

0.1 Preface

To extend the performance of the product and ensure personnel safety, please read this manual thoroughly before using the inverter. Should there be any problem in using the product that cannot be solved with the information provided in the manual, contact our technical or sales representative who will be willing to help you.

※Precautions

The inverter is an electrical product. For your safety, there are symbols such as “Danger”, “Caution” in this manual as a reminder to pay attention to safety instructions on handling, installing, operating, and checking the inverter. Be sure to follow the instructions for highest safety.



Danger

Indicates a potential hazard that could cause death or serious personal injury if misused.



Caution

Indicates that the inverter or the mechanical system might be damaged if misused.

⚠ Danger

- Risk of electric shock. The DC link capacitors remain charged for five minutes after power has been removed. It is not permissible to open the equipment until 5 minutes after the power has been removed.
- Do not make any connections when the inverter is powered on. Do not check parts and signals on circuit boards during the inverter operation.
- Do not disassemble the inverter or modify any internal wires, circuits, or parts.
- Ensure that the Inverter Ground terminal is connected correctly.

⚠ Caution

- Do not perform a voltage test on parts inside the inverter. High voltage can destroy the semiconductor components.
- Do not connect T1, T2, and T3 terminals of the inverter to any AC input power supply.
- CMOS ICs on the inverter’s main board are susceptible to static electricity. Do not touch the main circuit board.

Chapter 1 Safety Precautions

1.1 Before Power Up

Danger

- Make sure the main circuit connections are correct. Single phase L1(L),L3(N), and Three phase L1(L),L2,L3(N); 400V : L1,L2,L3 are power-input terminals and must not be mistaken for T1,T2 and T3. Otherwise, inverter damage can result.

Caution

- The line voltage applied must comply with the inverter's specified input voltage.(See the nameplate)
- To avoid the front cover from disengaging, or other damage do not carry the inverter by its covers. Support the drive by the heat sink when transporting. Improper handling can damage the inverter or injure personnel and should be avoided.
- To avoid the risk of fire, do not install the inverter on a flammable object. Install on nonflammable objects such as metal.
- If several inverters are placed in the same control panel, provide heat removal means to maintain the temperature below 50 degree C to avoid overheat or fire.
- When disconnecting the remote keypad, turn the power off first to avoid any damage to the keypad or the inverter.
- Installation limitation: -10~40°C

Warning

- This product is sold subject to EN 61800-3 and EN 61800-5-1.
In a domestic environment this product may cause radio interference in which case the user may be required to apply corrective measures.

Caution

- Work on the device/system by unqualified personnel or failure to comply with warnings can result in severe personal injury or serious damage to material. Only suitably qualified personnel trained in the setup, installation, commissioning and operation of the product should carry out work on the device/system.
- Only permanently-wired input power connections are allowed.

1.2 During Power Up

Danger

- When the momentary power loss is longer than 2 seconds, the inverter will not have sufficient stored power for its control circuit. Therefore, when the power is re-applied, the run operation of the inverter will be based on the setup of following parameters:

- Run parameters. 00-02 or 00-03.
- Direct run on power up. Parameter. 07-04 and the status of external run switch,

Note-: the start operation will be regardless of the settings for parameters 07-00/07-01/07-02.

Danger. Direct run on power up.

If direct run on power up is enabled and inverter is set to external run with the run FWD/REV switch closed then the inverter will restart.

Danger

Prior to use, ensure that all risks and safety implications are considered.

- When the momentary power loss ride through is selected and the power loss is short, the inverter will have sufficient stored power for its control circuits to function, therefore, when the

power is resumed the inverter will automatically restart depending on the setup of parameters 07-00 & 07-01.

1.3 Before Operation

Caution

- Make sure the model and inverter capacity are the same as that set in parameter 13-00.

Note: On power up the supply voltage set in parameter 01-01 will flash on display for 2 seconds.

1.4 During Operation

Danger

- Do not connect or disconnect the motor during operation. Otherwise, It may cause the inverter to trip or damage the unit.

Danger

- To avoid electric shock, do not take the front cover off while power is on.
- The motor will restart automatically after stop when auto-restart function is enabled. In this case, care must be taken while working around the drive and associated equipment .
- The operation of the stop switch is different than that of the emergency stop switch. The stop switch has to be activated to be effective. Emergency stop has to be de-activated to become effective.

Caution

- Do not touch heat radiating components such as heat sinks and brake resistors.
- The inverter can drive the motor from low speed to high speed. Verify the allowable speed ranges of the motor and the associated machinery.
- Note the settings related to the braking unit.
- Risk of electric shock. The DC link capacitors remain charged for five minutes after power has been removed. It is not permissible to open the equipment until 5 minutes after the power has been removed.

Caution

- The Inverter should be used in environments with temperature range from (14-104°F) or (-10 to 40°C) and relative humidity of 95%.

Danger

- Make sure that the power is switched off before disassembling or checking any components.

1.5 Inverter Disposal

Caution

Please dispose of this unit with care as an industrial waste and according to your required local regulations.

- The capacitors of inverter main circuit and printed circuit board are considered as hazardous waste and must not be burnt.
- The Plastic enclosure and parts of the inverter such as the cover board will release harmful gases if burnt.



Equipment containing electrical components may not be disposed of together with domestic waste. It must be separately collected with electrical and electronic waste according to local and currently valid legislation.

1.6 Guaranteed Liability Exemption

Loss of opportunity caused by the company's products, damage to customers of your company or your company, damage to non-company products, or compensation for other businesses, whether within the warranty period or not, is not covered by the company.

Chapter 2 Part Number Definition

2.1 Model Part Number

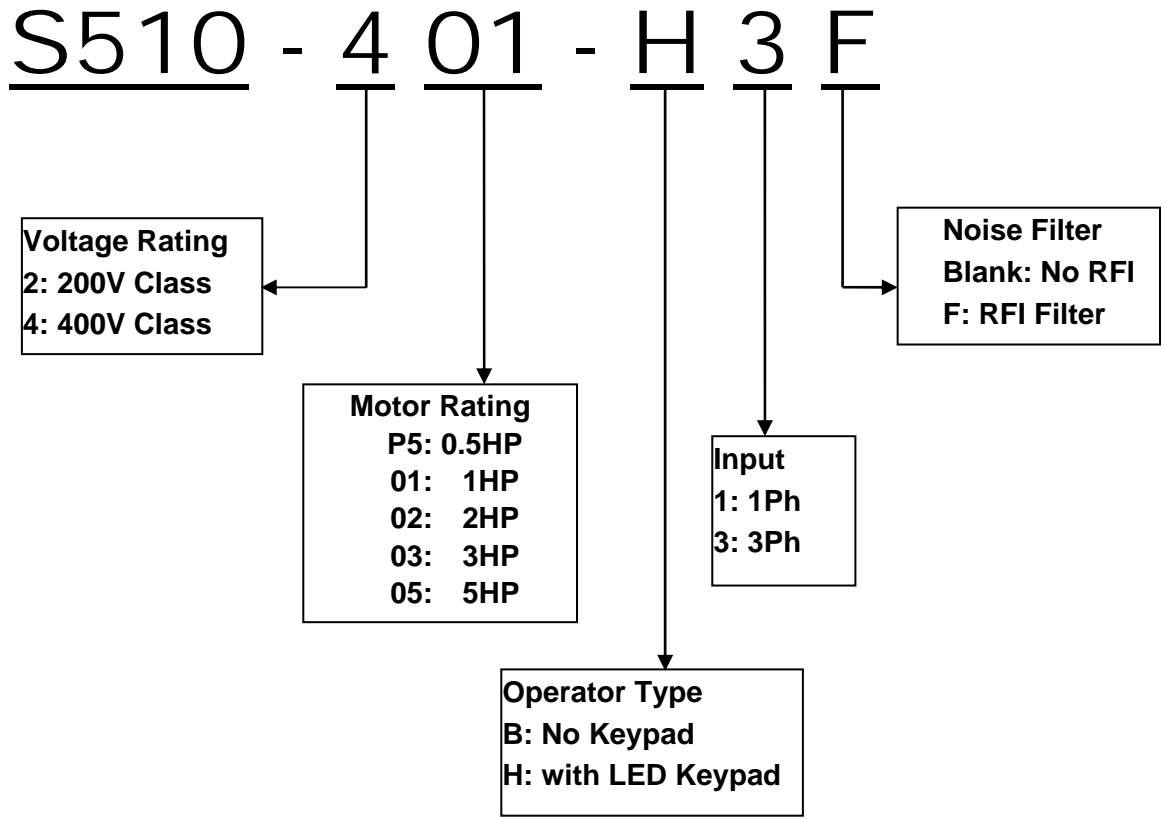

2.2 Standard Product Specification

Model	Supply Voltage (Vac)	HP	Rated Current (A)	Filter		Frame	Dimension(mm) (WxHxD)
				Built-in	None		
S510-2P5-H1F	1ph, 200~240V +10%/-15% 50/60Hz	0.5	2.6	☉		1	64x190x140
S510-201-H1F		1	4.3	☉		1	
S510-202-H1F		2	7.5	☉		2	64x230x155
S510-203-H1F		3	10.5	☉		2	
S510-401-H3	3ph, 380~480V +10%/-15% 50/60Hz	1	2.3		☉	1	64x190x140
S510-402-H3		2	3.8		☉	1	
S510-403-H3		3	5.2		☉	2	64x230x155
S510-405-H3		5	8.8		☉	2	
S510-401-H3F		1	2.3	☉		1	64x190x140
S510-402-H3F		2	3.8	☉		1	
S510-403-H3F		3	5.2	☉		2	64x230x155
S510-405-H3F		5	8.8	☉		2	

Short circuit capacity is below 5000A/240V or 5000A/480V, 200~240V models is 240V, 380~480V models is 480V.

Chapter 3 Environment & Installation

3.1 Environment

Installation environment has a direct effect on the correct operation and the life expectancy of the inverter, Install the inverter in an environment complying with the following conditions:

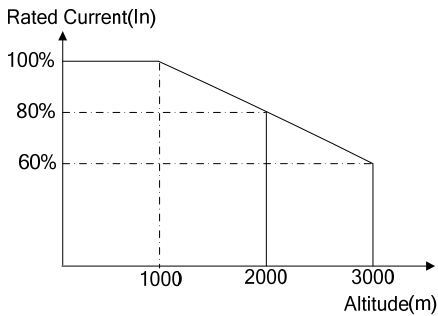
Protection											
Protection class	IP20 Open Type										
Suitable environment											
Operating temperature	-10~40°C If several inverters are installed in the same control panel, ensure adequate spacing and provide the necessary cooling and ventilation for successful operation.										
Storage temperature	-20~60°C										
Relative Humidity	95% RH below (without condensation)										
Altitude	<p>Altitude : Below 1000m (3281ft)</p> <p>It is required to reduce 2% of inverter rated current at each additional 100m. The maximum altitude is 3000m</p>  <table border="1"> <caption>Altitude vs Rated Current</caption> <thead> <tr> <th>Altitude (m)</th> <th>Rated Current (In)</th> </tr> </thead> <tbody> <tr> <td>0</td> <td>100%</td> </tr> <tr> <td>1000</td> <td>80%</td> </tr> <tr> <td>2000</td> <td>60%</td> </tr> <tr> <td>3000</td> <td>40%</td> </tr> </tbody> </table>	Altitude (m)	Rated Current (In)	0	100%	1000	80%	2000	60%	3000	40%
Altitude (m)	Rated Current (In)										
0	100%										
1000	80%										
2000	60%										
3000	40%										
Vibration	<p>Frequency: 10Hz - 150Hz - 10Hz</p> <p>Amplitude(0.3mm): 10Hz ≤ f ≤ 57Hz</p> <p>Acceleration(2G): 57Hz ≤ f ≤ 150Hz</p> <p>(According to IEC60068-2-6 standard)</p>										

Installation site

Install in an environment that will not have an adverse effect on the operation of the unit and ensure that there is no exposure to areas such as that listed below:-

- Direct sunlight, Rain or moisture
- Oil mist and salt
- Dust, lint fibres, small metal filings and corrosive liquid and gas
- Electromagnetic interference from sources such as welding equipment
- Radioactive and flammable materials
- Excessive vibration from machines such as stamping, punching machines
- Add vibration-proof pads if necessary

Product Overview

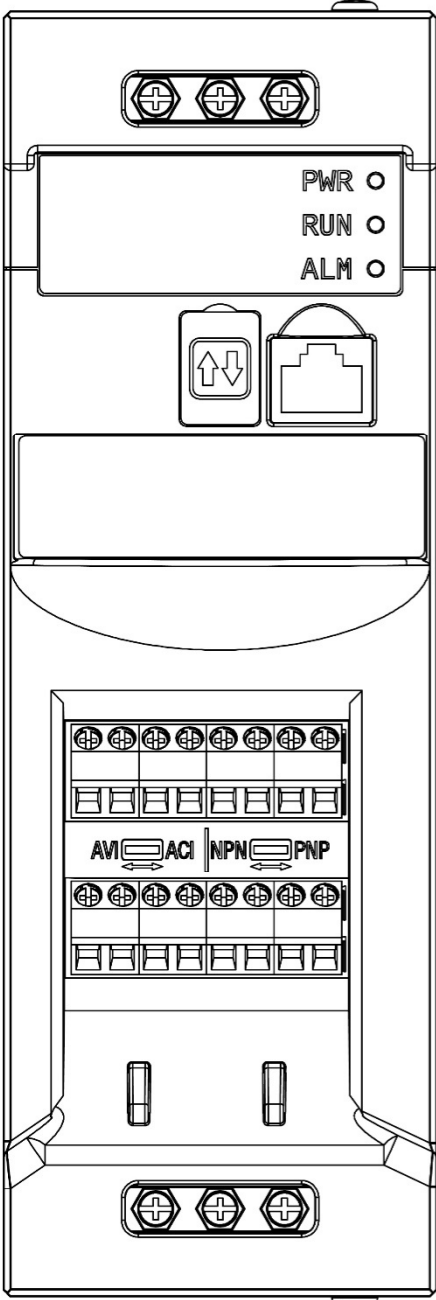

Frame 1

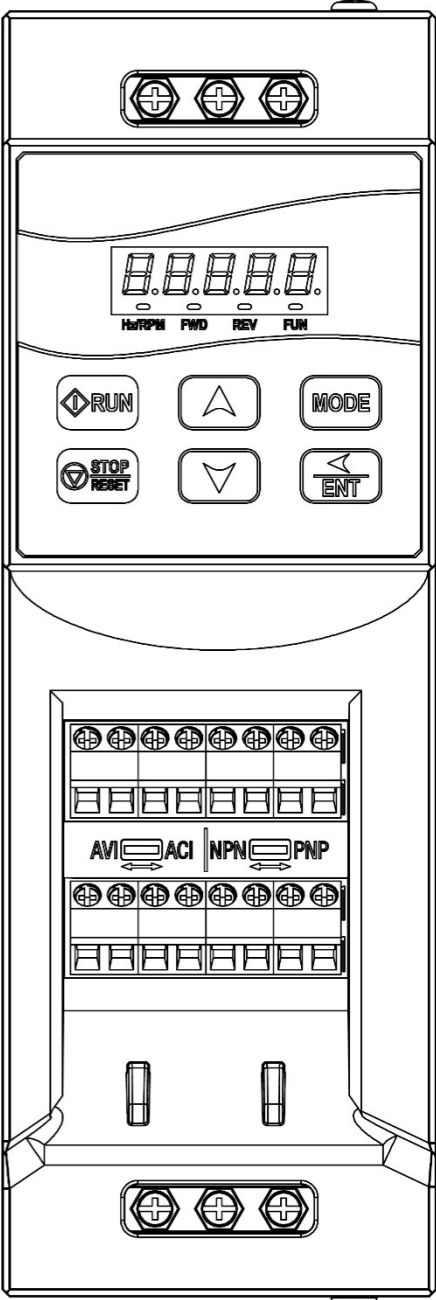

Frame 1 (with Keypad)

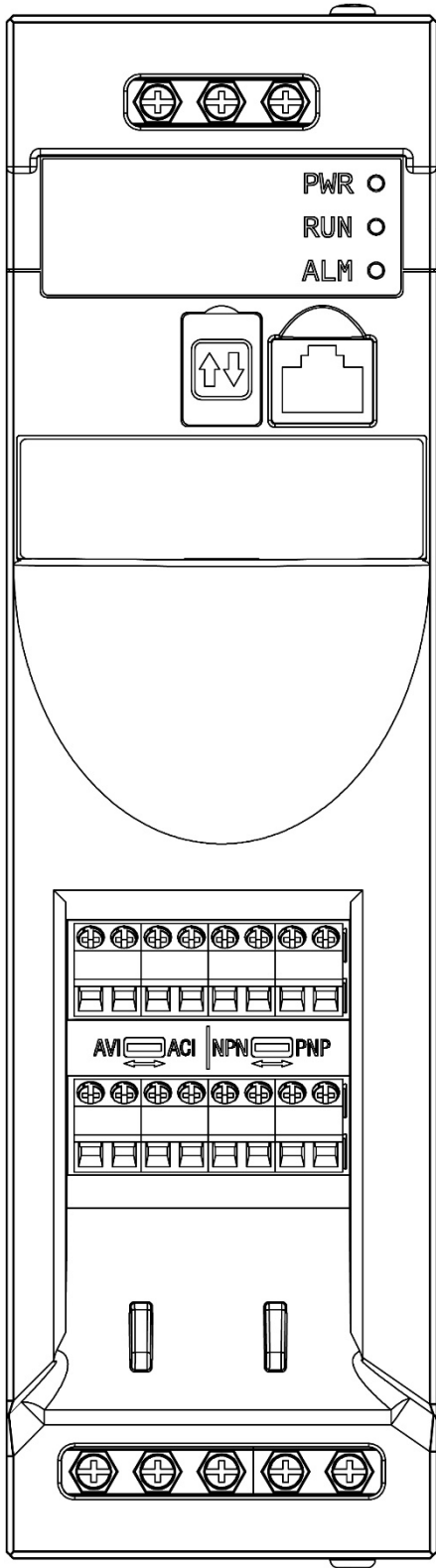

Frame 2

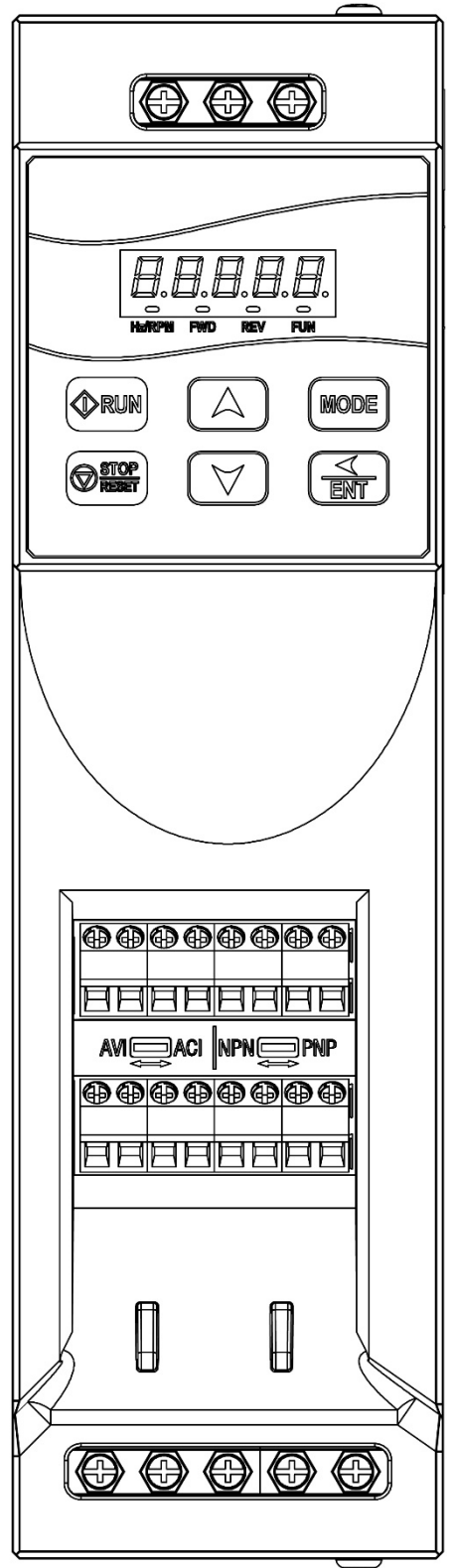

Frame 2 (with Keypad)

3.2 Installation

3.2.1 Installation methods

Mounting on a flat surface:

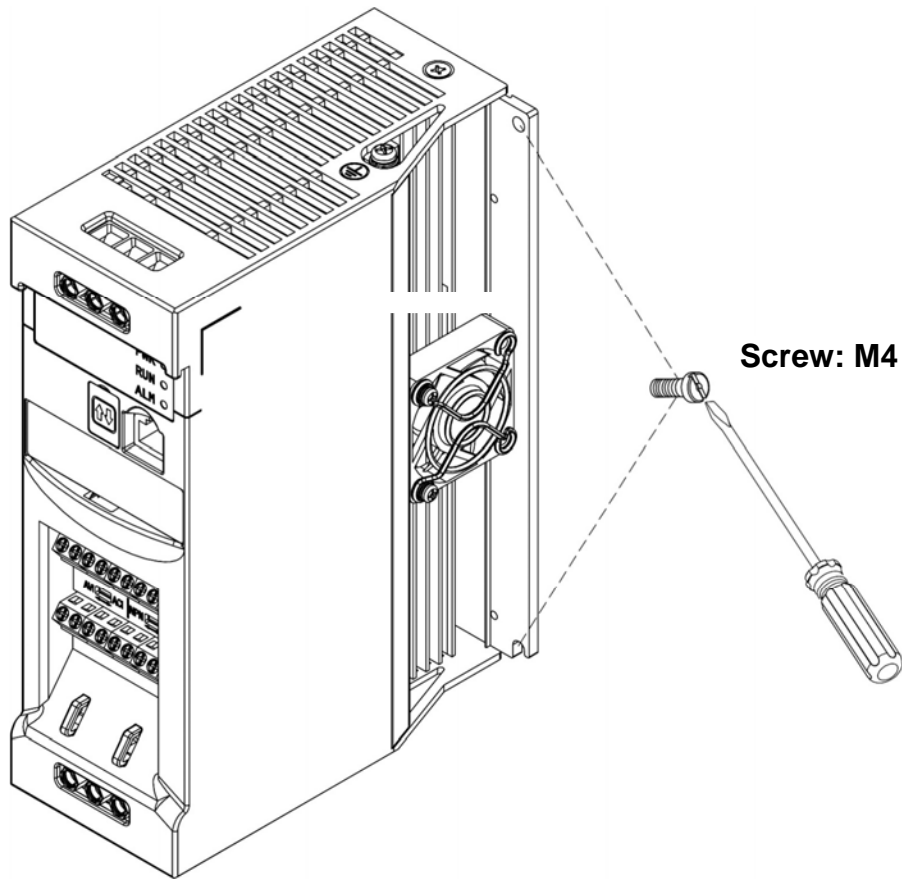

Din rail type installation:

Din rail kit includes a plastic base and a metal pressure plate.

Assembly Steps:-

- 1) Push the plastic base into the slot at the bottom of the heat sink of the machine by pressing the right arrow as shown in the figure.
- 2) Install the metal pressure plate and lock 6 fixing screws.

Disassembly Steps:-

- 1) Remove 6 fixing screws and remove the metal pressure plate.
- 2) Pull the plastic base from the bottom of the machine's heat sink by pressing the left arrow as shown in the figure.

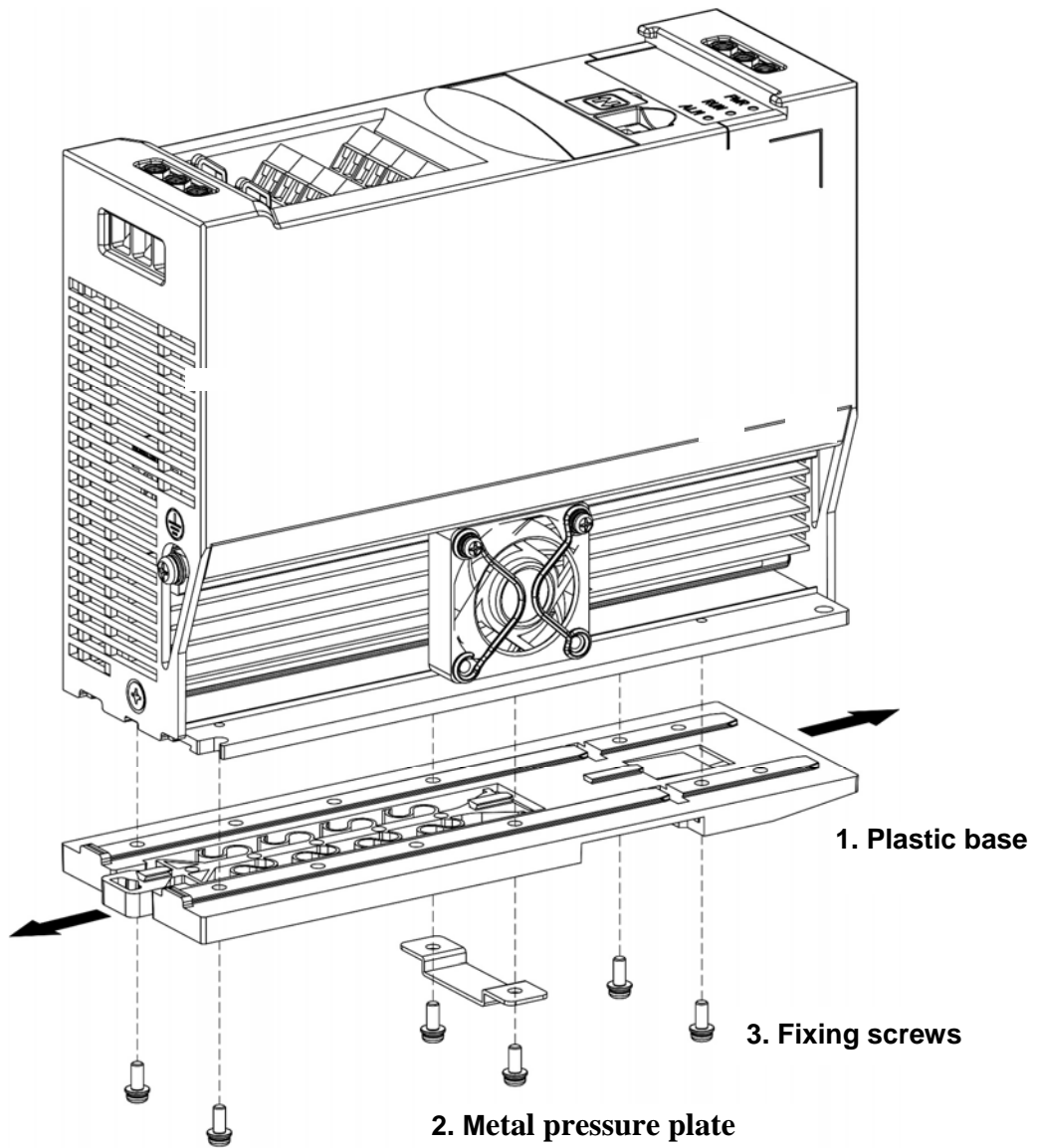

Note: JN5-DIN-S01 (Frame 1 Din-rail kit model number, including the following parts:

1. Plastic base
2. Metal pressure plate
3. Fixing screws: M3×6

Din Rail Mounting & Dismounting as shown in the diagram below : Use a 35mm Din Rail.

Mounting

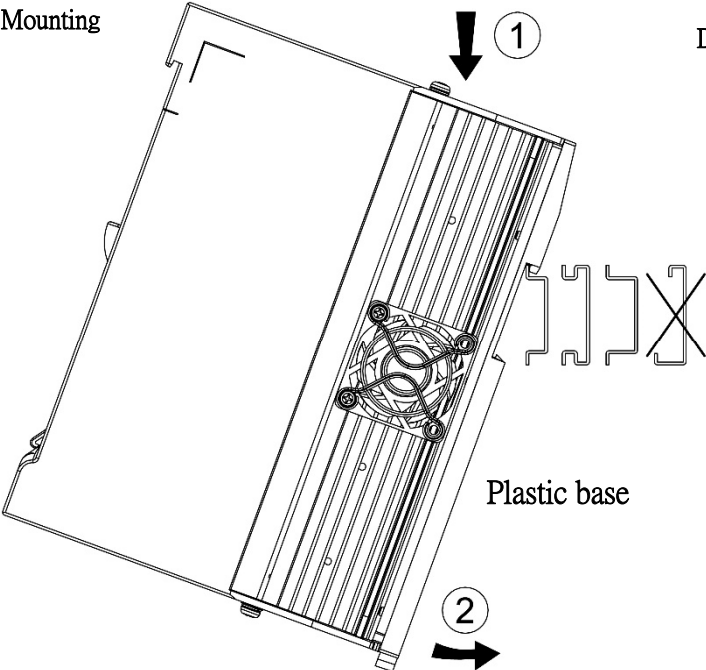

Dismounting

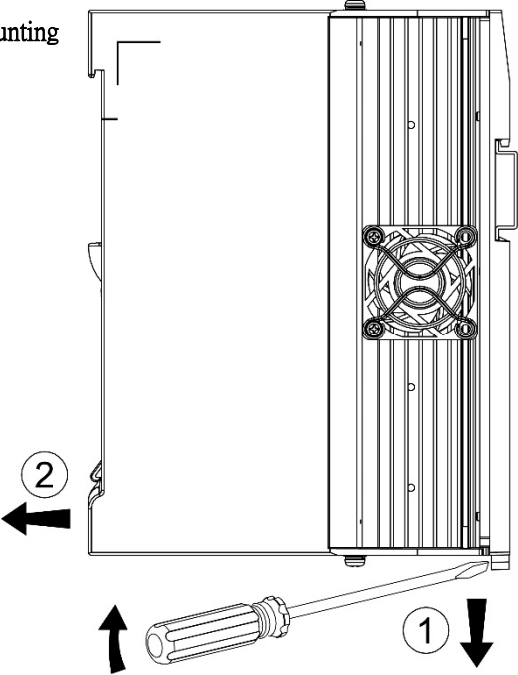

3.2.2 Installation space

Provide sufficient air circulation space for cooling as shown in examples below. Install the Inverter on surfaces that provide good heat dissipation.

Single unit Installation

Install the inverter vertically to obtain effective cooling.

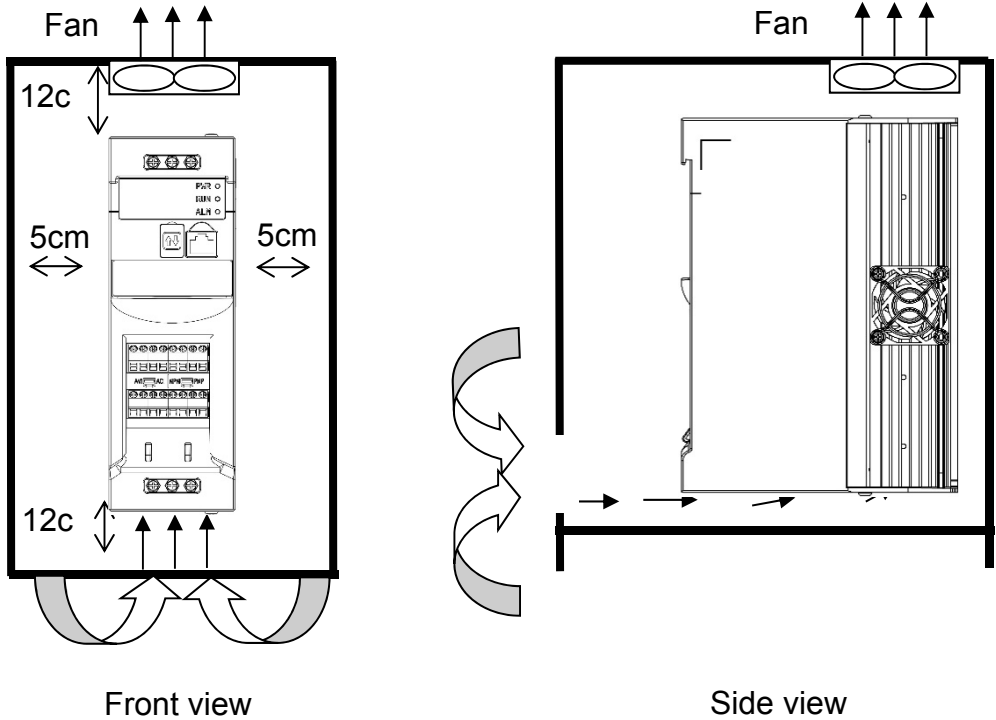

Front view

Side view

Side by side Installation

Provide the necessary physical space and cooling based on the ambient temperature and the heat loss in the panel

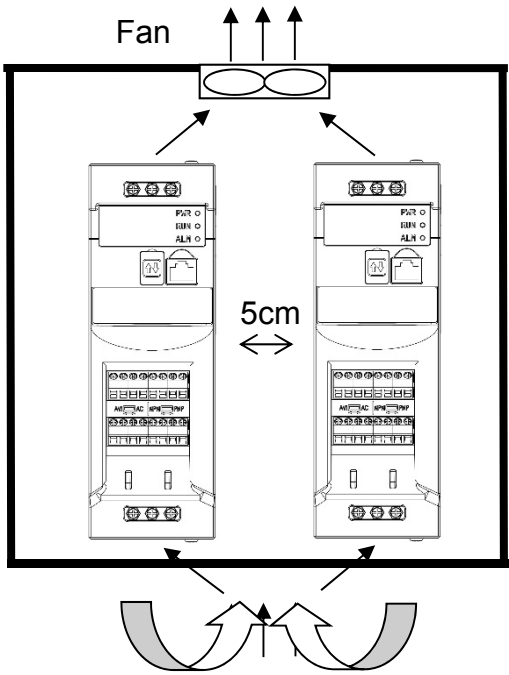

3.2.3 De-rating curve

Curves below show the applicable output current de-rate due to setting of carrier frequency.

2P5/201

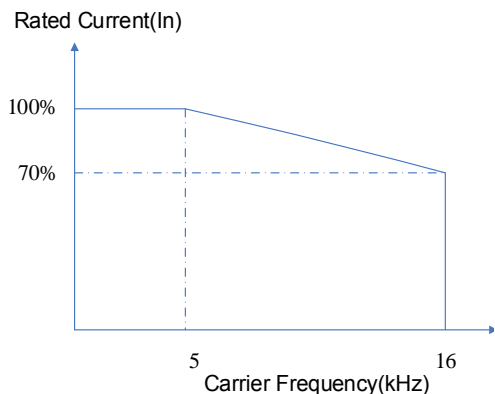

202/203

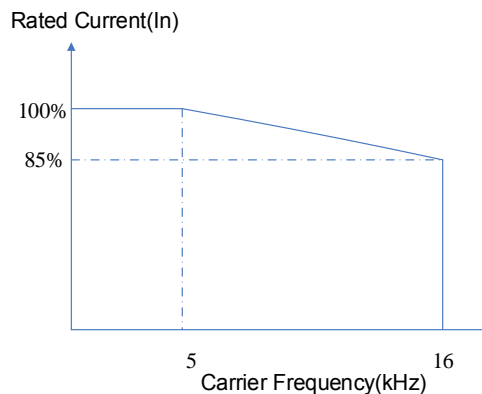

401/402

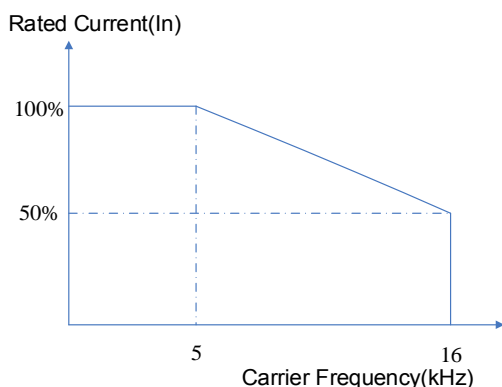

403/405

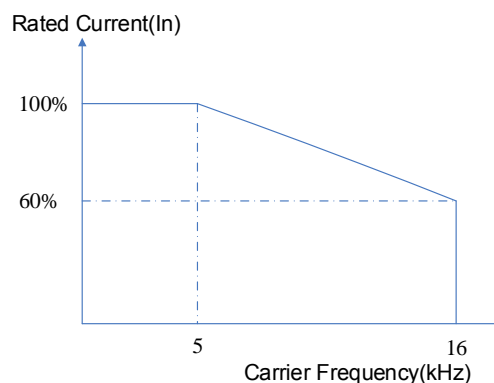

3.2.4 Capacitor reforming Guide after long storage

For correct performance of this product after long storage before use it is important that Inverter Capacitors are reformed according to the guide below:

Storage time	Procedure to re-apply voltage
≤ 1 year	Apply rated voltage(Note1) of inverter in the normal way
Between 1-2 years	Apply rated voltage of inverter to the product for one hour before using the inverter
≥ 2 years	Use a variable AC power supply to 1. Connecting 25% rated voltage of inverter for 30 minutes. 2. Connecting 50% rated voltage of inverter for 30 minutes. 3. Connecting 75% rated voltage of inverter for 30 minutes. 4. Connecting 100% rated voltage of inverter for 210 minutes. Once the procedure 1~4 completed, inverter just can be used normally.

Note: Rated voltage: please refer the rated voltage according to model label of inverter.

3.3 Wiring Guidelines

3.3.1 Main considerations

- 1 Tightening Torque for Screw terminals : Refer to the tables 3-1, when using a screwdriver or any other suitable tools to make connections.
- 2 Power terminals:
 Single phase : L1 (L), L3 (N)
 Three-phase 200V models: L1 (L), L2, L3 (N)
 400V models: L1, L2, L3
- 3 For all cabling use copper wires and the cable size shall be according to the table below rated at 105 degrees Celsius.
- 4 Power & Control cable Minimum rated voltage
 240V AC system, 300V AC.
 480V AC system, 600V AC.
- 5 Control cables should be separated from the power cables. Do not place them in the same cable tray or cable trunking to prevent against electrical interference.

Table 3-1

Model	Input terminal					Output terminal					Control terminal				
	Cable size		Tightening torque			Cable size		Tightening torque			Cable size		Tightening torque		
	AWG	mm ²	kgf.cm	lbf.in	N.m	AWG	mm ²	kgf.cm	lbf.in	N.m	AWG	mm ²	kgf.cm	lbf.in	N.m
2P5/201	12~10	4~6	8.17	7.02	0.8	14~10	2.5~6	8.17	7.02	0.8	24~12	0.5~2.5	4.09	3.5	0.4
202/203	10	6	8.17	7.02	0.8	12~10	4~6	8.17	7.02	0.8	24~12	0.5~2.5	4.09	3.5	0.4
401/402	12~10	4~6	8.17	7.02	0.8	14~10	2.5~6	8.17	7.02	0.8	24~12	0.5~2.5	4.09	3.5	0.4
403/405	12~10	4~6	8.17	7.02	0.8	14~10	2.5~6	8.17	7.02	0.8	24~12	0.5~2.5	4.09	3.5	0.4

- 6 The maximum RMS symmetrical Current Ratings and voltage are listed as below:

Device Rating		Short circuit Rating	Maximum Voltage
voltage	HP		
220V	0.4~3	5000A	240V
440V	1~5	5000A	480V

- 7 Electrical ratings of terminals:

Horsepower	Power Specification	Voltage (Volt)	Current(A)
0.5/1	220~240V	600	30
2/3	220~240V		
1/2	380~480V		
3/5	380~480V		

3.3.2 Power Cables.

Supply power cable must be connected to Input terminal block, terminals L1(L) and L3(N) for single phase 200V supply, L1(L), L2, L3(N) for three phase 200V supply and L1, L2, L3 for three phase 400V supply.

Motor cable must be connected to Motor terminals. T1, T2, T3.

Warning:- Connection of Supply line cable to motor terminals T1,T2& T3 will result in serious damage to the drive components.

Example power connections: Inverter with dedicated power line.

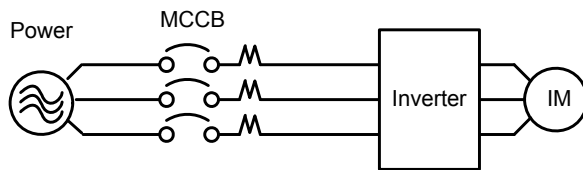

- Install a Supply RFI filter or Isolation transformer when the power source is shared with other high power electrical equipment as shown below.

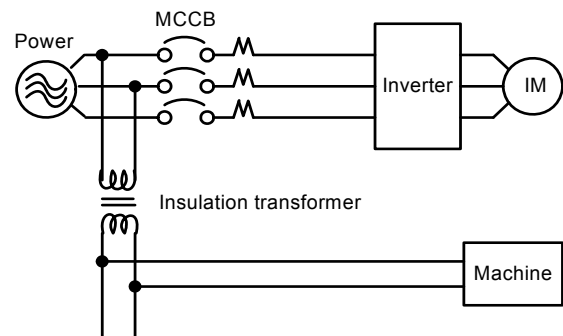
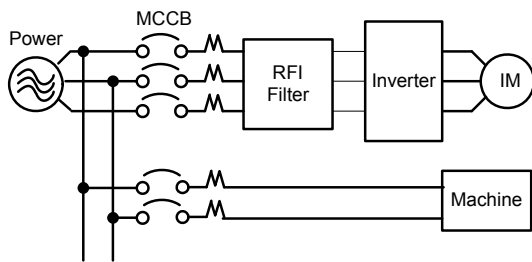

3.3.3 Control Cable selection and Wiring.

Control cables should be connected to control terminal block.

Choose power & Control cables according to the following criteria:-

- Use copper wires with correct diameter and temperature rating of 60/75°C.
- Minimum cable voltage rating for 200V type inverters should be 300VAC.
- Route all cables away from other high voltage or high current power lines to reduce interference effects.

Use a twisted pair shielded cable and connect the shield (screen) wire to the ground terminal at the inverter end only. Cable length should not exceed 50 meters.

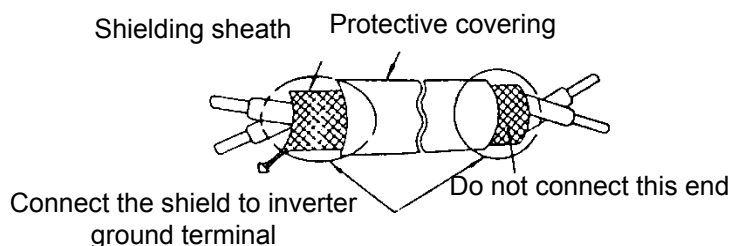

3.3.4 Wiring and EMC guidelines.

For effective interference suppression, do not route power and control cables in the same conduit or trunking.

To prevent radiated noise, motor cable should be put in a metal conduit. Alternatively an armored or shielded type motor cable should be used.

For effective suppression of noise emissions the cable armor or shield must be grounded at both ends to the motor and the inverter ground. These connections should be as short as possible.

Motor cable and signal lines of other control equipment should be at the least 30 cm apart.

S510 has a built in Class "A" EMC filter to first Environment Restricted. (Category C2). For some installations such as residential,(Category C1) an optional external Class "B" type filter will be necessary. Please consult your local supplier.

Typical Wiring.

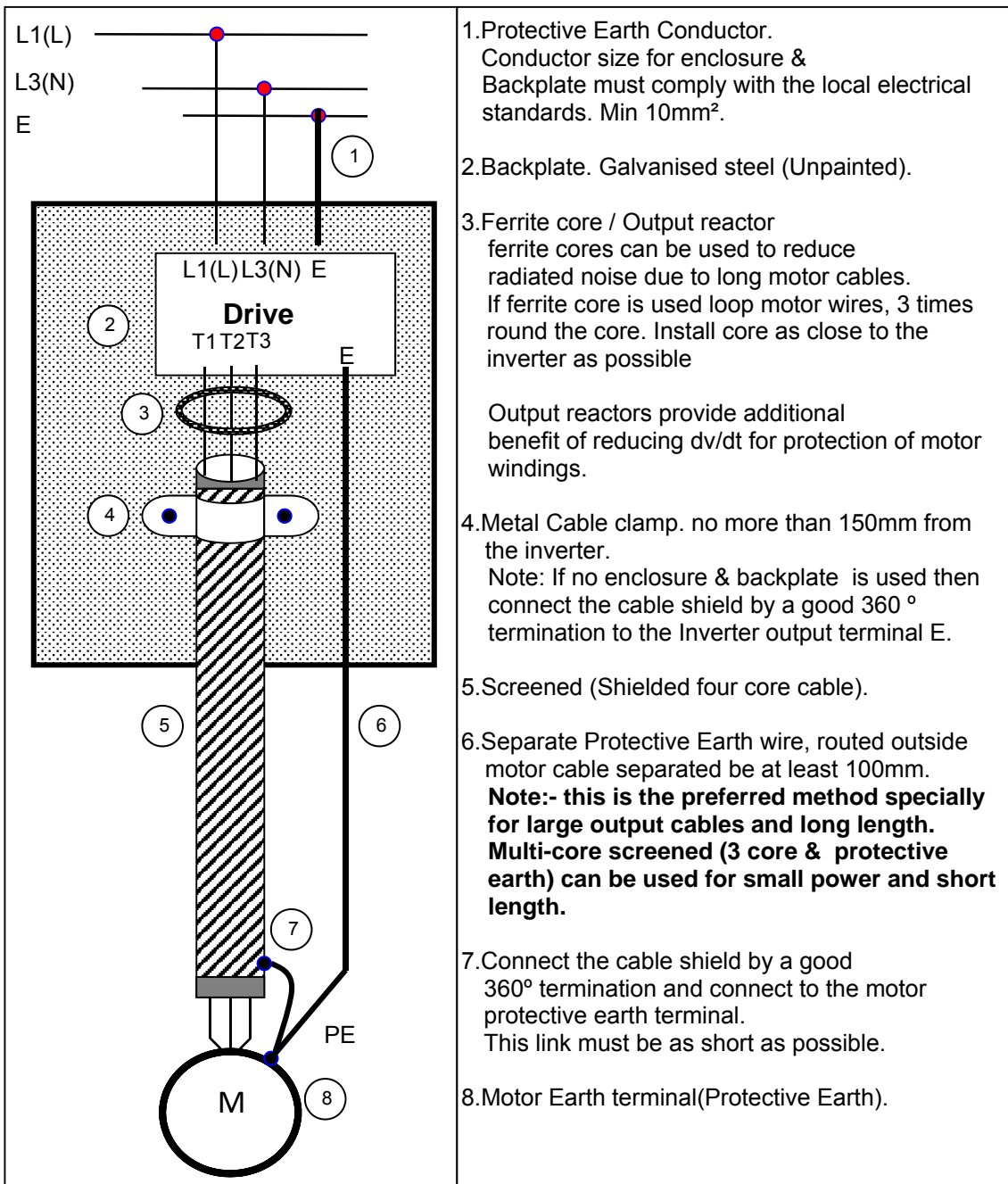

3.3.5 Failure liability

- Teco bears no responsibility for any failures or damaged caused to the inverter if the recommendations in this instruction manual have not been followed specifically points listed below,
- If a correctly rated fuse or circuit breaker has not been installed between the power source and the inverter.
- If a magnetic contactor, a phase capacitor, burst absorber and LC or RC circuits have been connected between the inverter and the motor.
- If an incorrectly rated three-phase squirrel cage induction motor has been used

Note:

When one inverter is driving several motors, the total current of all motors running simultaneously must be less than the rated current of the inverter, and each motor has to be equipped with a correctly rated thermal overload relay.

3.3.6 Considerations for peripheral equipment

	<table border="1"> <tr> <td data-bbox="442 311 678 454">Power</td> <td data-bbox="678 311 1418 454">Ensure that the supply voltage is correct. A molded-case circuit breaker or fused disconnect must be installed between the AC source and the inverter</td> </tr> <tr> <td data-bbox="442 454 678 736">Circuit Breaker & RCD</td> <td data-bbox="678 454 1418 736">Use a molded-case circuit breaker that conforms to the rated voltage and current of the inverter. Do not use the circuit breaker as the run/stop switch for the inverter. Residual Current Circuit Breaker(RCD) Current setting should be 200mA or above and the operating time at 0.1 second or longer to prevent malfunctions.</td> </tr> <tr> <td data-bbox="442 736 678 983">Magnetic contactor</td> <td data-bbox="678 736 1418 983">Normally a magnetic contactor is not needed. A contactor can be used to perform functions such as external control and auto restart after power failure. Do not use the magnetic contactor as the run/stop switch for the inverter.</td> </tr> <tr> <td data-bbox="442 983 678 1162">AC reactor for power quality improvement</td> <td data-bbox="678 983 1418 1162">When a 200V/400V inverter with rating below 15KW is connected to a high capacity power source (600kVA or above) then an AC reactor can be connected for power factor improvement and reducing harmonics.</td> </tr> <tr> <td data-bbox="442 1162 678 1341">Input noise filter</td> <td data-bbox="678 1162 1418 1341">Inverter has a built-in filter to Class "A" first Environment. (CategoryC2) To satisfy the required EMC regulations for your specific application you may require an additional EMC filter.</td> </tr> <tr> <td data-bbox="442 1341 678 1731">Inverter</td> <td data-bbox="678 1341 1418 1731">Connect the single phase power to Terminals, L1(L) & L3(N) and three phase power to Terminals : (200V : L1(L),L2,L3(N) or 400V : L1,L2,L3) Warning! Connecting the input terminals T1, T2, and T3 to AC input power will damage the inverter. Output terminals T1, T2, and T3 are connected to U, V, and W terminals of the motor. To reverse the motor rotation direction just swap any two wires at terminals T1, T2, and T3. Ground the Inverter and motor correctly. Ground Resistance for 200V power<100 Ohms.</td> </tr> <tr> <td data-bbox="442 1731 678 1964">Motor</td> <td data-bbox="678 1731 1418 1964">Three-phase induction motor. Voltage drop on motor due to long cable can be calculated. Volts drop should be < 10%. Phase-to-phase voltage drop (V) = $\sqrt{3} \times \text{resistance of wire } (\Omega/\text{km}) \times \text{length of line (m)} \times \text{current} \times 10^{-3}$</td> </tr> </table>	Power	Ensure that the supply voltage is correct. A molded-case circuit breaker or fused disconnect must be installed between the AC source and the inverter	Circuit Breaker & RCD	Use a molded-case circuit breaker that conforms to the rated voltage and current of the inverter. Do not use the circuit breaker as the run/stop switch for the inverter. Residual Current Circuit Breaker(RCD) Current setting should be 200mA or above and the operating time at 0.1 second or longer to prevent malfunctions.	Magnetic contactor	Normally a magnetic contactor is not needed. A contactor can be used to perform functions such as external control and auto restart after power failure. Do not use the magnetic contactor as the run/stop switch for the inverter.	AC reactor for power quality improvement	When a 200V/400V inverter with rating below 15KW is connected to a high capacity power source (600kVA or above) then an AC reactor can be connected for power factor improvement and reducing harmonics.	Input noise filter	Inverter has a built-in filter to Class "A" first Environment. (CategoryC2) To satisfy the required EMC regulations for your specific application you may require an additional EMC filter.	Inverter	Connect the single phase power to Terminals, L1(L) & L3(N) and three phase power to Terminals : (200V : L1(L),L2,L3(N) or 400V : L1,L2,L3) Warning! Connecting the input terminals T1, T2, and T3 to AC input power will damage the inverter. Output terminals T1, T2, and T3 are connected to U, V, and W terminals of the motor. To reverse the motor rotation direction just swap any two wires at terminals T1, T2, and T3. Ground the Inverter and motor correctly. Ground Resistance for 200V power<100 Ohms.	Motor	Three-phase induction motor. Voltage drop on motor due to long cable can be calculated. Volts drop should be < 10%. Phase-to-phase voltage drop (V) = $\sqrt{3} \times \text{resistance of wire } (\Omega/\text{km}) \times \text{length of line (m)} \times \text{current} \times 10^{-3}$
Power	Ensure that the supply voltage is correct. A molded-case circuit breaker or fused disconnect must be installed between the AC source and the inverter														
Circuit Breaker & RCD	Use a molded-case circuit breaker that conforms to the rated voltage and current of the inverter. Do not use the circuit breaker as the run/stop switch for the inverter. Residual Current Circuit Breaker(RCD) Current setting should be 200mA or above and the operating time at 0.1 second or longer to prevent malfunctions.														
Magnetic contactor	Normally a magnetic contactor is not needed. A contactor can be used to perform functions such as external control and auto restart after power failure. Do not use the magnetic contactor as the run/stop switch for the inverter.														
AC reactor for power quality improvement	When a 200V/400V inverter with rating below 15KW is connected to a high capacity power source (600kVA or above) then an AC reactor can be connected for power factor improvement and reducing harmonics.														
Input noise filter	Inverter has a built-in filter to Class "A" first Environment. (CategoryC2) To satisfy the required EMC regulations for your specific application you may require an additional EMC filter.														
Inverter	Connect the single phase power to Terminals, L1(L) & L3(N) and three phase power to Terminals : (200V : L1(L),L2,L3(N) or 400V : L1,L2,L3) Warning! Connecting the input terminals T1, T2, and T3 to AC input power will damage the inverter. Output terminals T1, T2, and T3 are connected to U, V, and W terminals of the motor. To reverse the motor rotation direction just swap any two wires at terminals T1, T2, and T3. Ground the Inverter and motor correctly. Ground Resistance for 200V power<100 Ohms.														
Motor	Three-phase induction motor. Voltage drop on motor due to long cable can be calculated. Volts drop should be < 10%. Phase-to-phase voltage drop (V) = $\sqrt{3} \times \text{resistance of wire } (\Omega/\text{km}) \times \text{length of line (m)} \times \text{current} \times 10^{-3}$														

(For detailed information for the above peripheral equipment refer to Chapter 6)

3.3.7. Ground connection

Inverter Ground terminal must be connected to installation ground correctly and according to the required local wiring regulations.

- Ground cable size must be according to the required local wiring regulations. Ground connection should be as short as possible.
- Do not share the ground of the inverter with other high current loads (Welding machine, high power motors). Ground each unit separately.
- Ensure that all ground terminals and connections are secure
- Do not make ground loops when several inverters share a common ground point.

Note: Please leave at least 5cm while installing inverter side by side in order to provide enough cooling space.

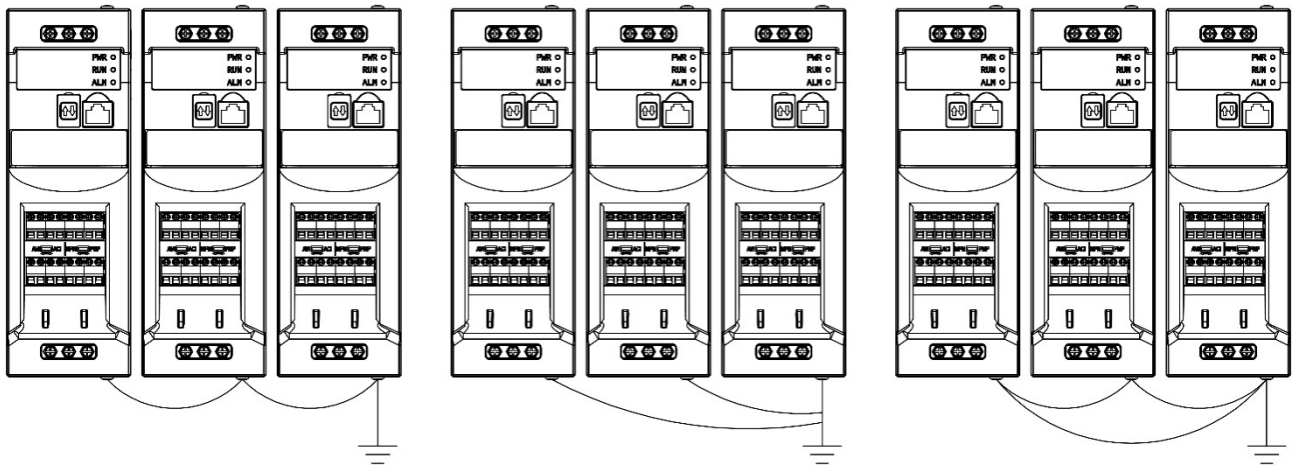

(a) Correct

(b) Correct

(c) Incorrect

3.4 Specifications

3.4.1 Product Specifications

200V Class : Single phase

Model : S510-□□□-B/H1F	2P5	201	202	203
Horse power (HP)	0.5	1	2	3
Suitable motor capacity (kW)	0.4	0.75	1.5	2.2
Rated output current (A)	2.6	4.3	7.5	10.5
Rated capacity (kVA)	1.00	1.65	2.90	4.00
Input voltage range(V)	Single Phase: 200~240V(+10%-15%), 50/60HZ			
Output voltage range(V)	Three phase 0~240V			
Input current (A)	4.8	7.6	13.7	16.4
Weight (KG)	1.1	1.1	1.4	1.4
Allowable momentary power loss time (s)	1.0	1.0	2.0	2.0
Enclosure	IP20			

400V Class: Three phase

Model : S510-□□□-B/H3F	401	402	403	405
Horse power (HP)	1	2	3	5
Suitable motor capacity (kW)	0.75	1.5	2.2	3.7
Rated output current (A)	2.3	3.8	5.2	8.8
Rated capacity (kVA)	1.7	2.9	4.0	7.0
Input voltage range(V)	Three Phase: 380~480V (+10%-15%), 50/60HZ			
Output voltage range(V)	Three phase 0~480V			
Input current (A)	3.3	4.5	7.3	12.5
Weight(KG)	1.2	1.2	1.6	1.6
Allowable momentary power loss time (s)	2.0	2.0	1.5	1.5
Enclosure	IP20			

*The input current is calculated value at full rated output current.

3.4.2 General Specifications

Item		S510
Control Mode		V/F Control
Frequency	Range	0.01~599.00Hz
	Speed accuracy (100% torque)	3%
	Starting Torque	3Hz / 100%
	Setting resolution	Digital input : 0.01Hz Analog input : 0.015Hz/60Hz
	Frequency Setting	Keypad : Set directly with ▲ ▼ keys External Input Terminals: AV(0/2~10V or 0/4~20mA) analog input Multifunction input up/down function (Group3) Setting frequency by Communication method. Remote control: Set directly with ▲ ▼ keys of remote keypad
	Frequency limit	Lower and upper frequency limits, 3 -skip frequency settings.
Run	Operation set	Keypad run, stop button External terminals: Multi- operation-mode 2 / 3 wire selection Jog operation Run signal by communication method. Remote control: Set directly with run, stop button of remote keypad
Main Controls	V/F curve setting	6 fixed curve and one customized curve
	Carrier frequency	1~16kHz(default 5kHz)
	Acceleration and deceleration control	2 off Acc / dec time parameters, 4 off S curve parameters.
	Multifunction input	19 functions (refer to description on group3) 4 points
	Multifunction output	16 functions (refer to description on group3)
	Multifunction analog output	5 functions (refer to description on group4), 1 point (0~10V)
	Main features	Overload Detection, 8 Preset speeds, Auto-run, Acc/Dec Switch, Main/Alt run Command select, Main/Alt Frequency Command select, PID control, torque boost, V/F start Frequency ,Fault reset.
Display	LED	Display: parameter/parameter value/frequency/line speed/DC voltage/output voltage/output current/PID feedback/input and output terminal status/Heat sink temperature/Program Version/Fault Log.
	LED Status Indicator	For run/stop/forward and reverse.

Protective Functions	Overload Protection	Integrated motor and Inverter overload protection. (150% rated current for 60sec, every 10 minutes)
	Over voltage	100V/200V : Over 410V, 400V : Over 820V
	Under voltage	100V/200V : Under 190V, 400V : Under 380V
	Momentary Power Loss Restart	Inverter auto-restart after a momentary power loss.
	Stall Prevention	Stall prevention for Acceleration/ Deceleration/ and continuous Run.
	Short-circuit output terminal	Electronic Circuit Protection
	Grounding Fault	Electronic Circuit Protection
	Additional protective functions	heatsink over temperature protection, Auto carrier frequency reduction with temperature rise, fault output, reverse prohibit, Number of auto restart attempts, Parameter lock, over voltage protection(OVP), motor PTC over-temperature protection
International Certification		CE/UL/cUL/RCM
Communication		RS485 (Modbus) built in, with one to one or one to many control. Profibus, DeviceNet, CANopen, TCP/IP, EtherNet/IP by gateways.
Environment	Operating temperature	-10~50°C(with fan), -10~40°C(without fan)
	Storage temperature	-20~60°C
	Humidity	Under 95%RH (no condensation)
	Vibration	Frequency: 10Hz - 150Hz - 10Hz Amplitude(0.3mm): 10Hz \leq f \leq 57Hz Acceleration(2G): 57Hz \leq f \leq 150Hz (According to IEC60068-2-6 standard)
	EMC Compliance	EN61800-3, First Environment (Use of the optional grounding kit is recommended to achieve compliance.).
	LVD Compliance	EN 61800-5-1
	Electrical Safety	UL61800-5-1
	Protection level	IP20

3.5 Standard wiring

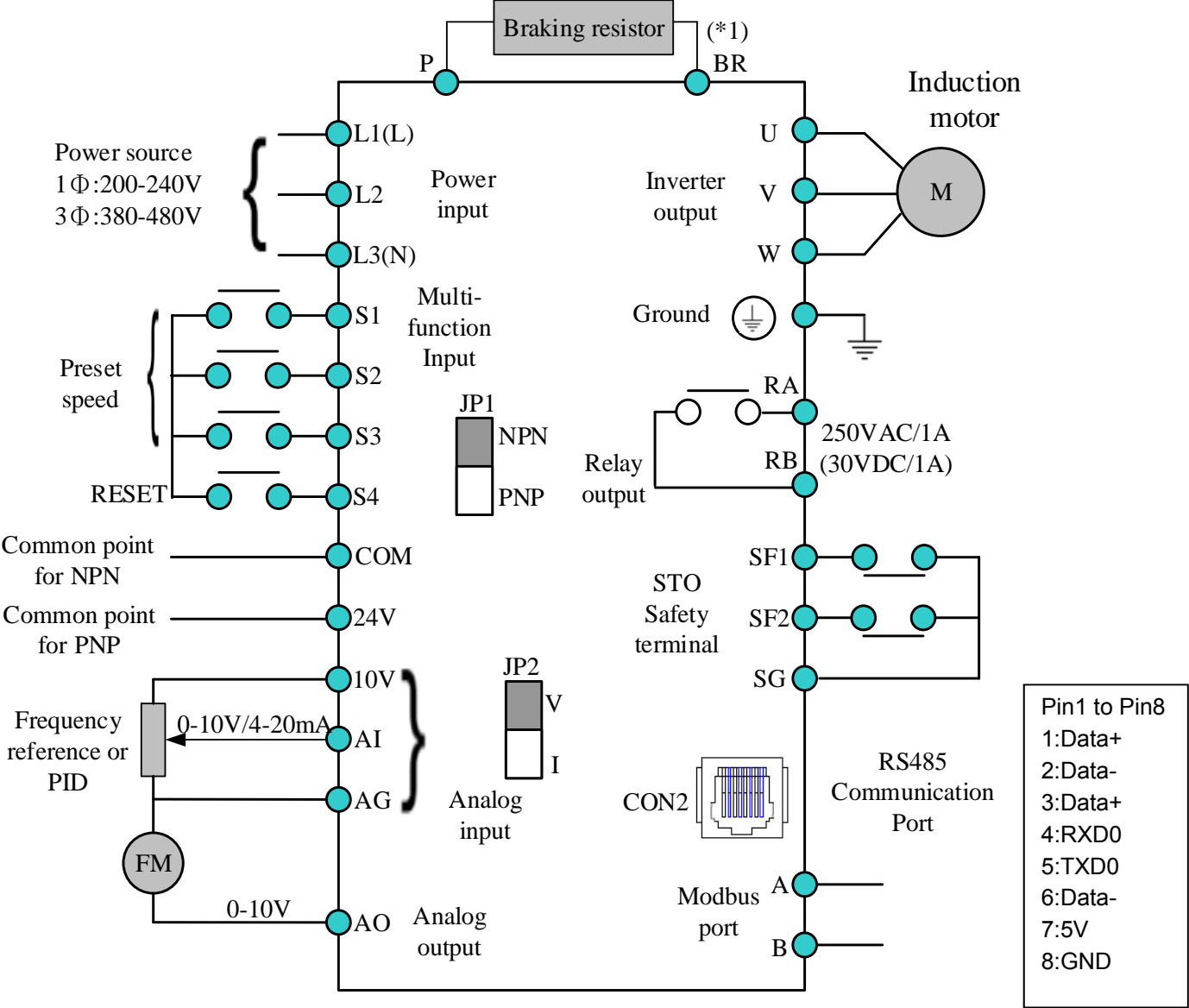

*1: P/BR terminal is used for braking resistor, only available for the models of frame 2.

3.6 Terminal Description

3.6.1 Description of main circuit terminals

Terminal symbols	TM1 Function Description
L1(L)	Main power input
L2	
L3(N)	
P*	Externally connected braking resistor
BR*	
T1	Inverter output, connect to U, V, W terminals of motor
T2	
T3	
	Ground terminal

*P, BR is only for the model of frame 2.

Frame 1:



Frame 2:



3.6.2 Description of control circuit terminals

Terminal symbols	TM2 Function Description	Signal Level
RA	Relay output terminal, Specification: 250VAC/1A(30VDC/1A)	250VAC/1A(30VDC/1A)
RB		
COM	S1~S4 (common point) 【NPN】	±15%,Max output current 30mA
SG(+24V)	S1~S4 (common point) 【PNP】	
S1~S4	Multi-function input terminals(refer to group3)	24 VDC, 4.5 mA, optical coupling isolation (Max voltage30 VDC, Input impedance 6kΩ)
A	RS485 communication terminal +	
B	RS485 communication terminal —	
10V	Built in power for an external speed potentiometer	10V,(Max current:20mA)
AI	Analog voltage input, Specification : 0/2~10VDC (selected by parameter 04-00)	0~10V(Input impedance 200kΩ)
	Analog current input, Specification : 0/4~20mA (selected by parameter 04-00)	0~20mA(Input impedance 249Ω)
AO	Multi-function analog output terminal. Maximum output 10VDC/1mA	0~10V(Max current 2mA)
SF1/ SF2	SF is a safety switch, which is normally closed contact when leaving the factory. When the state is changed to normally open, the inverter will cut off the output	
NC	No function, it's useless	

Control terminals

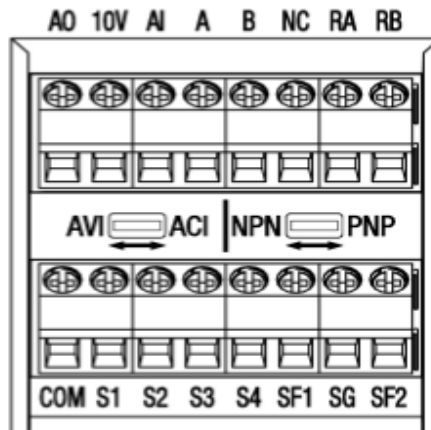

JUMPER function description

Icon	Function	Factory Setting
	NPN/PNP selection	Without filter: NPN With filter: PNP
	Analog Signal selection AVI : 0/2~10VDC signal ACI : 0~20mA signal	AVI

3.7 Outline Dimensions(unit: mm)

Tolerance Table				
0~6±0.8	6~30±1.5	30~120±2.5	120~315±4.0	315~1000±6.0

Frame 1

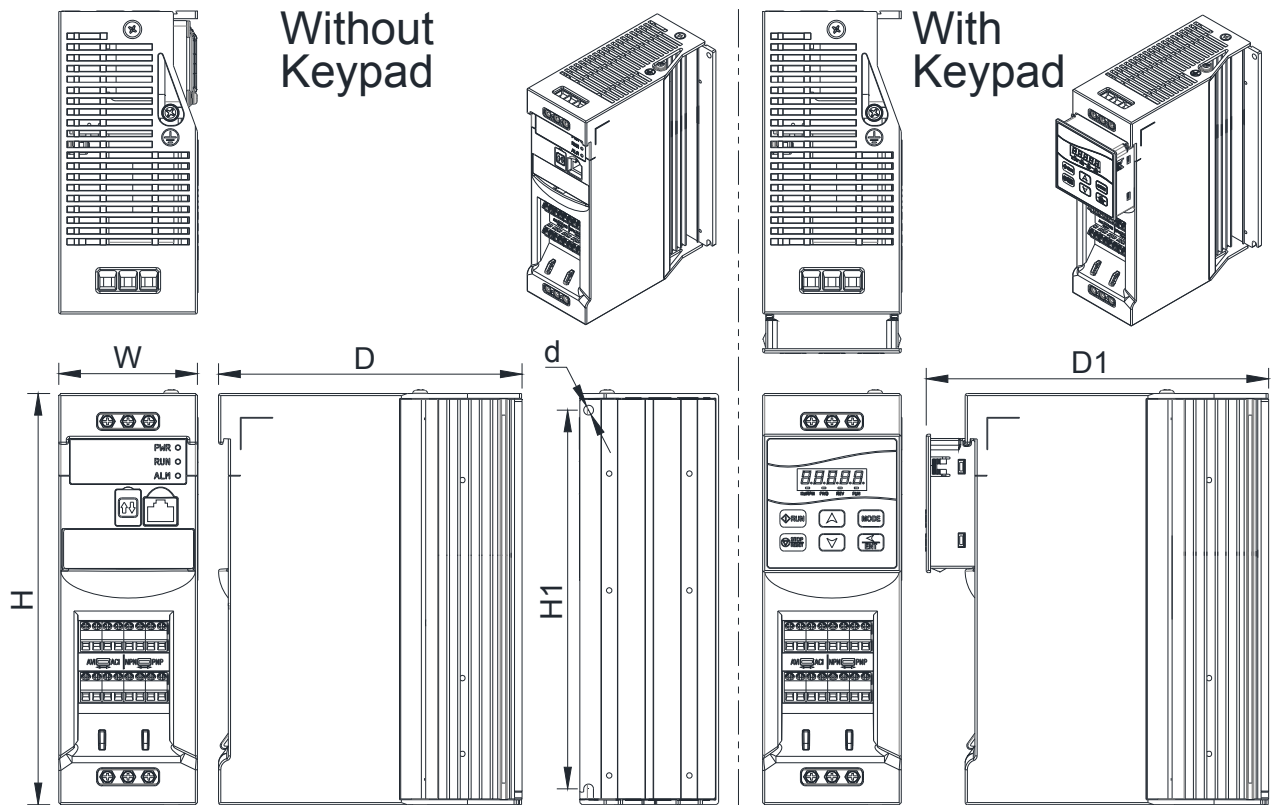

Model	Dimension (mm)					
	W	H	D	D1	H1	d
S510-2P5-B1F	64	190	140	158	175	4.5
S510-201-B1F						
S510-401-B3F						
S510-402-B3F						
S510-2P5-H1F						
S510-201-H1F						
S510-401-H3F						
S510-402-H3F						

Frame 2

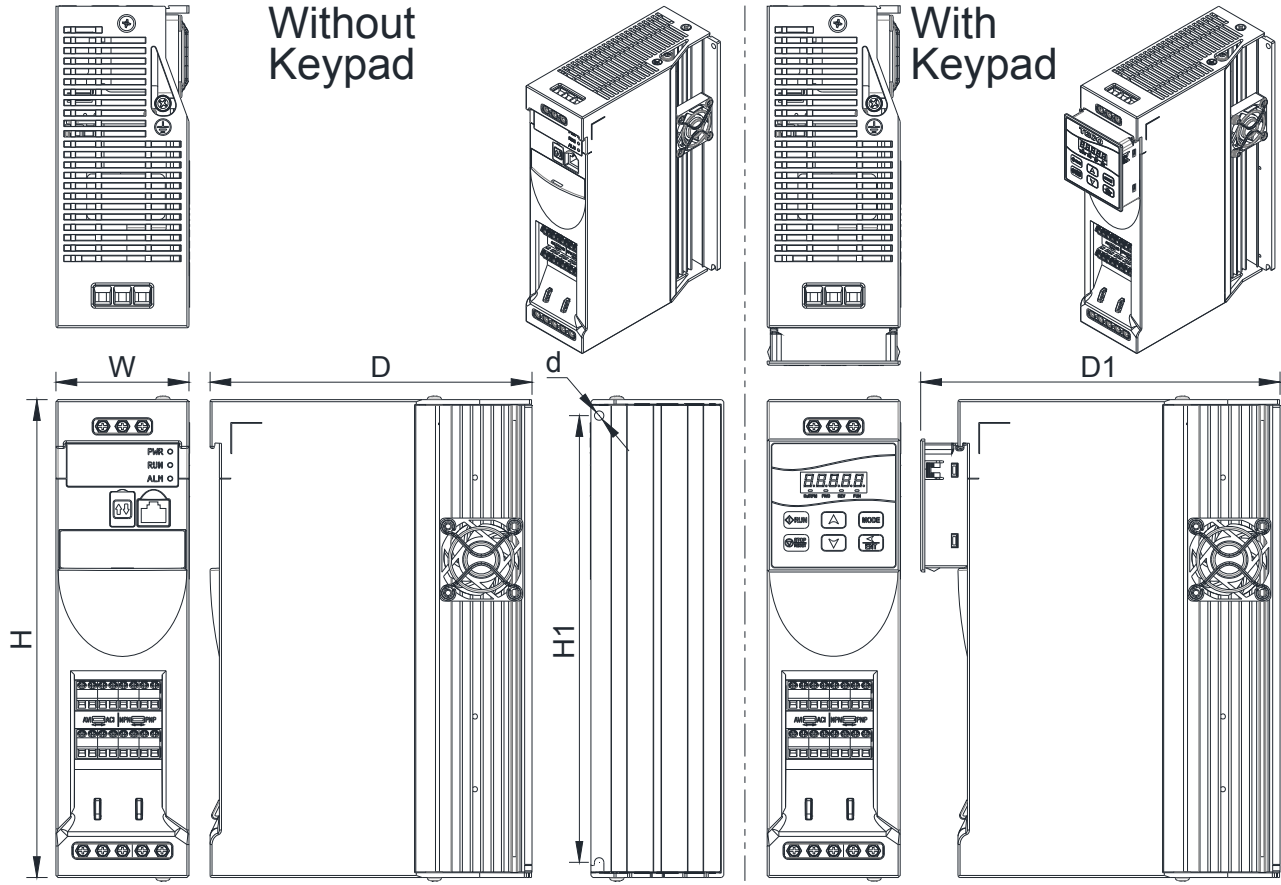

Model	Dimension (mm)					
	W	H	D	D1	H1	d
S510-202-B1F	64	230	155	173	215	4.5
S510-203-B1F						
S510-403-B3F						
S510-405-B3F						
S510-202-H1F						
S510-203-H1F						
S510-403-H3F						
S510-405-H3F						

3.8 EMC Filter Disconnection

EMC filter may be disconnected:

Inverter drives with built-in EMC filter are not suitable for connection to certain type of supply systems, such as listed below; in these cases the RFI filter can be disabled.

In all such cases consult your local electrical standards requirements.

IT type supply systems (ungrounded) & certain supply systems for medical equipment.

For ungrounded supply systems, if the filter is not disconnected the supply system becomes connected to Earth through the Y capacitors on the filter circuit. This could result in danger and damage to the Drive.

Disconnection steps:

1. Remove EMC filter screw by screwdriver.

Note: Disconnecting the EMC filter link will disables the filter function, please consult your local EMC standards requirement.

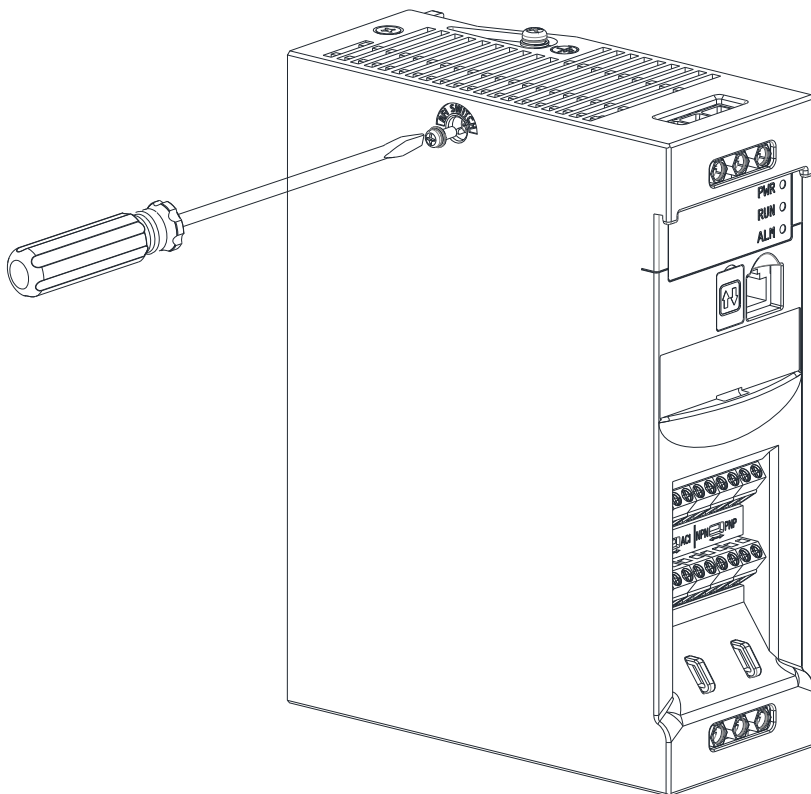

3.9 Keypad Installation

- Keypad component:
- 1. Keypad
 - 2. RJ45 Connector

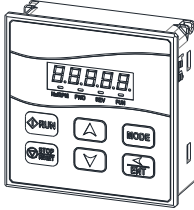

Keypad

RJ45 Connector

Keypad installation:
 Follow the step ①→②→③
 Note: The RJ45 buckle must be inserted into the inverter.
 Keypad uninstallation:
 Follow the step ④→⑤→⑥

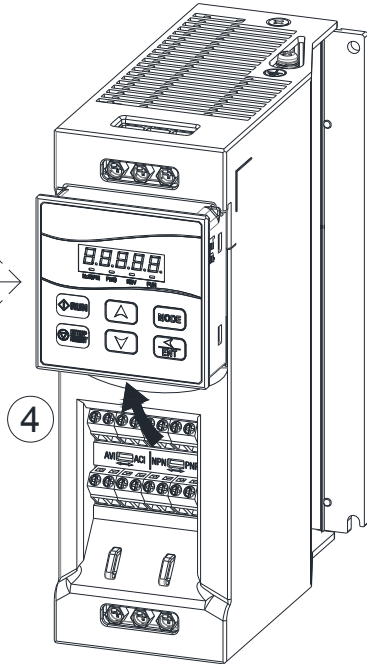
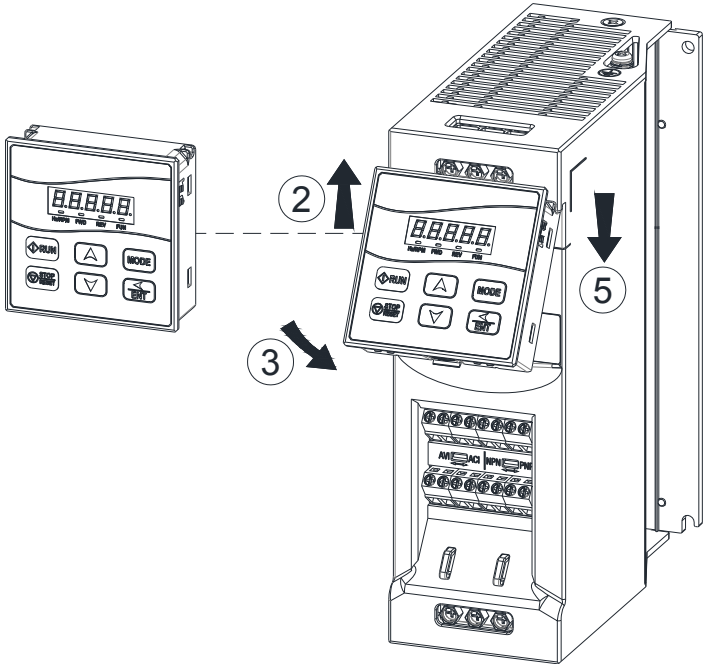
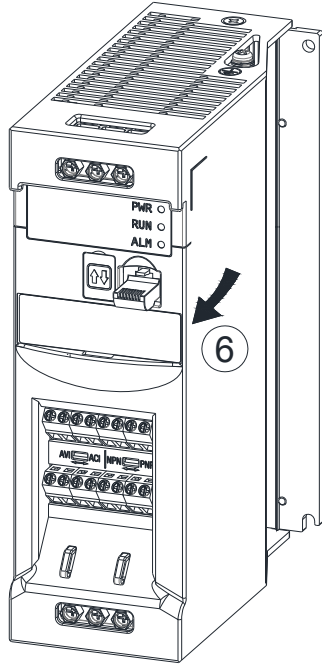
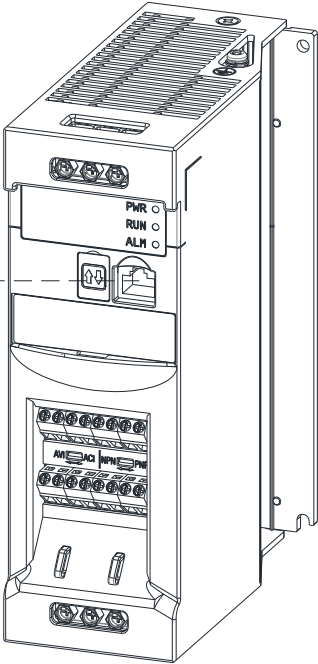
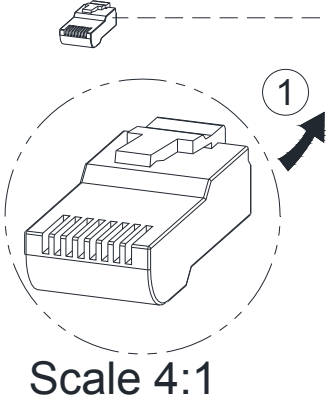

Chapter4 Software Index

4.1 Keypad Description (Keypad is optional)

4.1.1 Operator Panel Functions



Type	Item	Function
Digital display & LEDs	Main digital displays	Frequency Display, Parameter, Voltage, Current, Temperature, Fault messages.
	LED Status	Hz/RPM: ON when the frequency or line speed is displayed. OFF when the parameters are displayed. FWD: ON while the inverter is running forward. Flashes while stopped. REV: ON while the inverter is running reverse. Flashes while stopped. FUN: ON when the parameters are displayed.
Variable Resistor	FREQ SET	Used to set the frequency
Keys On Keypad	RUN	RUN: Run at the set frequency.
	STOP/RESET (Dual function keys)	STOP: Decelerate or Coast to Stop. RESET: Use to Reset alarms or resettable faults.
	▲	Increment parameter number and preset values.
	▼	Decrement parameter number and preset values.
	MODE	Switch between available displays
	</ENTER (Dual function keys, a short press for left shift function, a long press for ENTER function)	"<" Left Shift: Used while changing the parameters or parameter values ENTER: Used to display the preset value of parameters and for saving the changed parameter values.

4.1.2 Digital display Description

Alpha numerical display format

Digit	LED	Letter	LED	Letter	LED	Symbol	LED
0		A		n		-	
1		b		o		°	
2		C		P		_	
3		d		q		.	
4		E		r			
5		F		S			
6		G		t			
7		H		u			
8		J		v			
9		L		Y			

Digital display indication formats

Actual output frequency	Set frequency	
Digits are lit Continually	Preset digits flashing	Selected digit flashing

LED display examples

Display	Description
	In stop mode shows the set frequency In run mode shows the actual output frequency
	Selected Parameter
	Parameter Value
	Output Voltage
	Output Current in Amps
	DC Bus voltage
	Temperature
	PID feedback value
	Error display
	Analogue Current / Voltage ACID / AVI . Range (0~1000)

LED Status description

	LED Indicator light Status			
Frequency / line speed Indicator	Hz/RPM	On		
Menu mode indicator	Fun	On while not displaying frequency or line speed		
FWD indicator	FWD	On while running forward		Flashing while stopped in Forward mode.
REV indicator light	REV	On while running reverse		Flashing while stopped in Reverse mode

4.1.3 Digital display setup

On power up digital display screens will be as shown below.

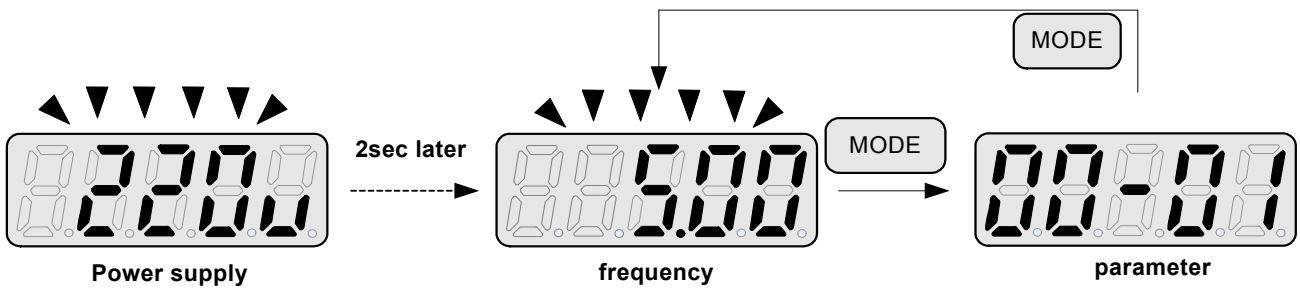

User selectable display formats:

12- 00	Display Mode								
	0 0 0 0 0								
	high Low								
	Each of the above 5 digits can be set to any of the selections below from 0 to 6								
Range	<table border="0"> <tr> <td>[0] :Disable display</td> <td>[1] :output Current</td> </tr> <tr> <td>[2] :output Voltage</td> <td>[3] :DC voltage</td> </tr> <tr> <td>[4] :Temperature</td> <td>[5] :PID feedback</td> </tr> <tr> <td>[6] :AVI/ACI value</td> <td></td> </tr> </table>	[0] :Disable display	[1] :output Current	[2] :output Voltage	[3] :DC voltage	[4] :Temperature	[5] :PID feedback	[6] :AVI/ACI value	
[0] :Disable display	[1] :output Current								
[2] :output Voltage	[3] :DC voltage								
[4] :Temperature	[5] :PID feedback								
[6] :AVI/ACI value									

The highest bit of 12-00 sets the power on the display, other bits set the selected display from range 0-6.as Listed above.

Example1: Set parameter 12- 00= [10000] to obtain display format shown below.

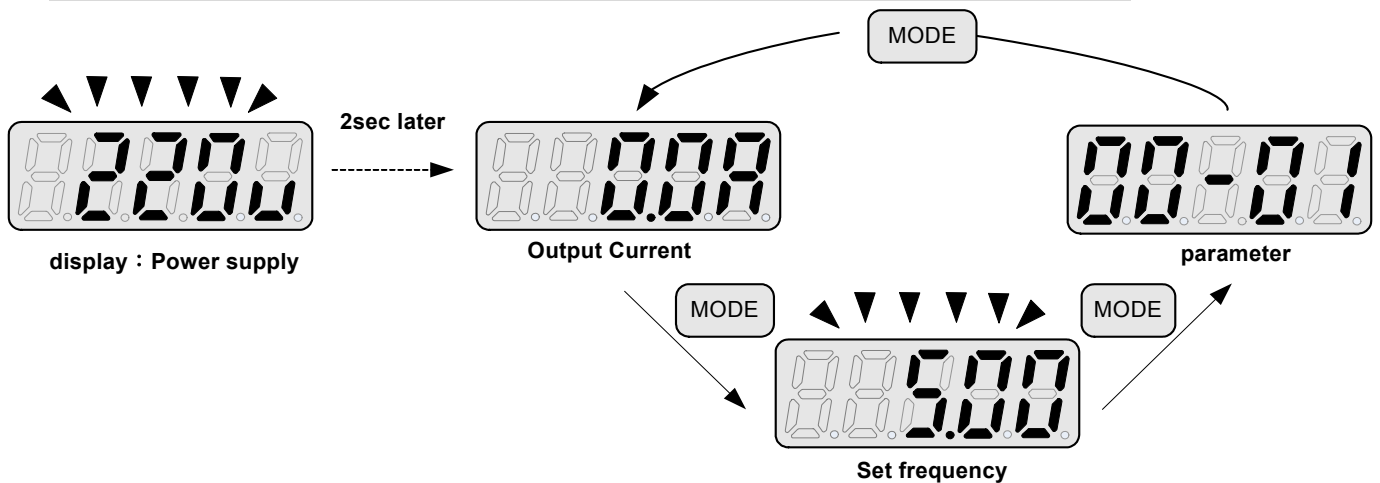

Example 2. Set parameter 2: 12- 00= [12345] to obtain the display format shown below.

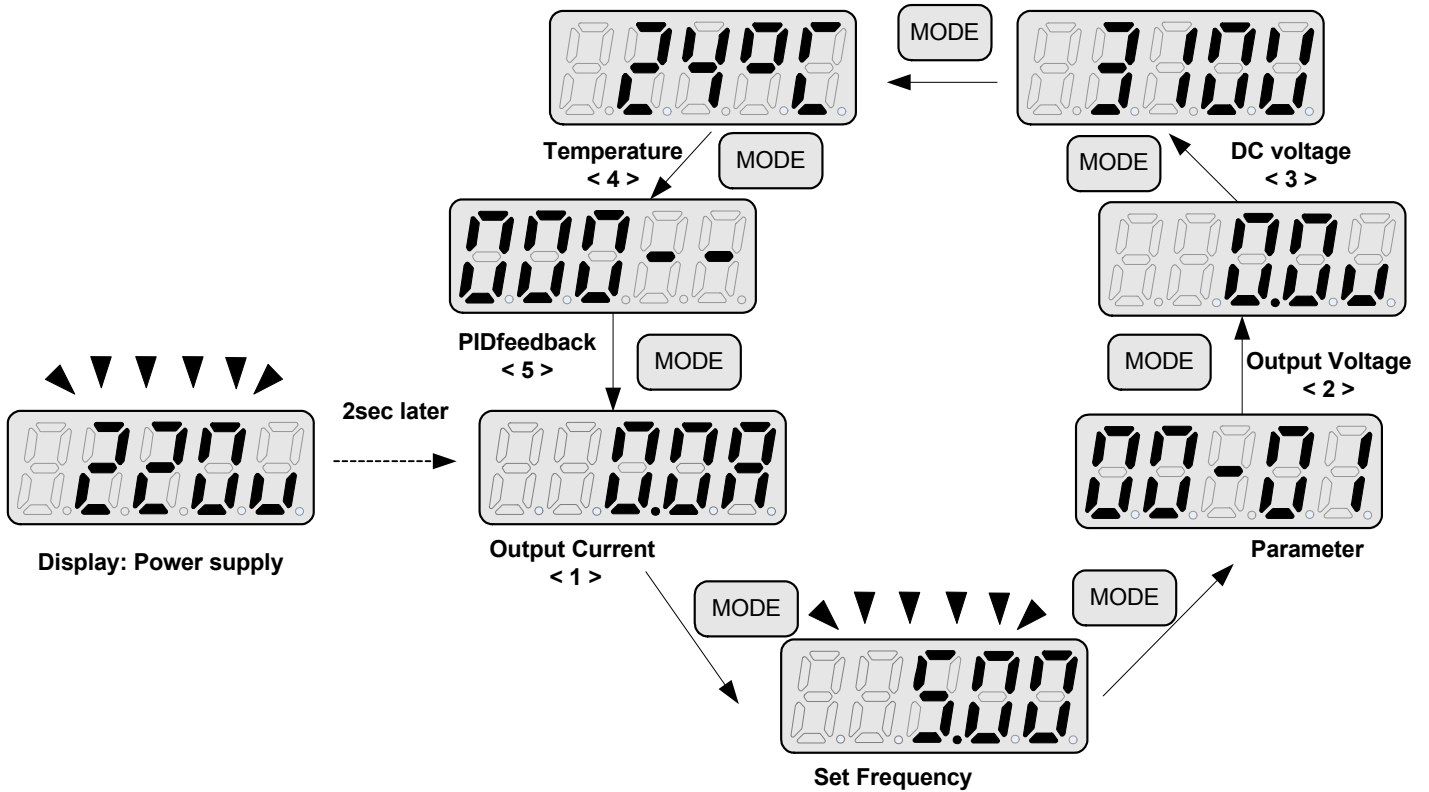

Increment/ Decrement key functions:

1. "▲"/"▼" :

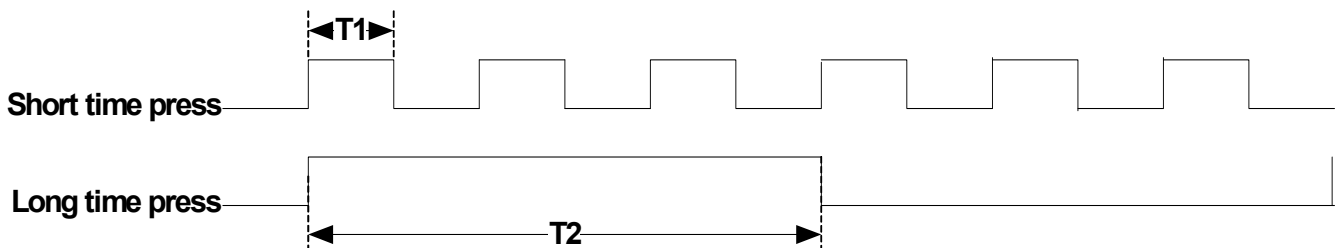

Quick pressing of these keys will Increment or Decrement the selected digit by one. Extended pressing will Increment or Decrement the selected digit continuously.

2. "</ENT" Key functions :

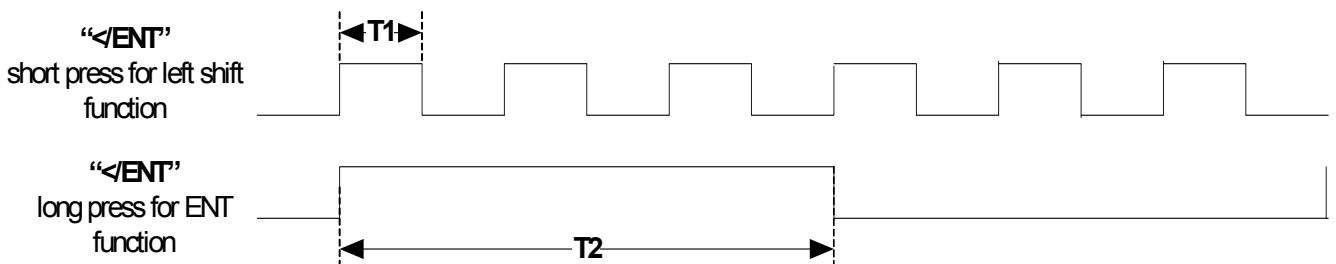

Quick pressing of this key will display the preset value of the parameter selected. Extended pressing of this key will save the altered value of the selected parameter.

4.1.4 Example of keypad operation

Example1: Modifying Parameters

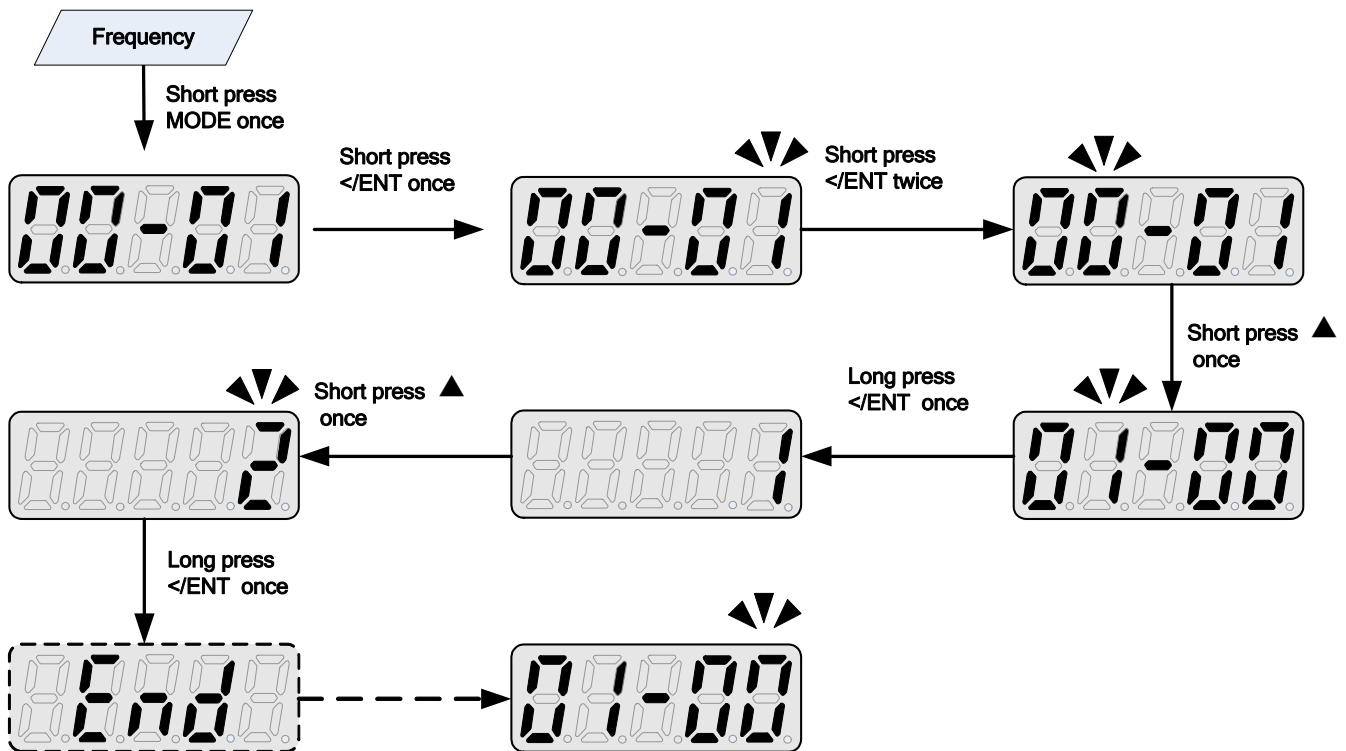

Example2: Modifying the frequency from keypad in run and stop modes.

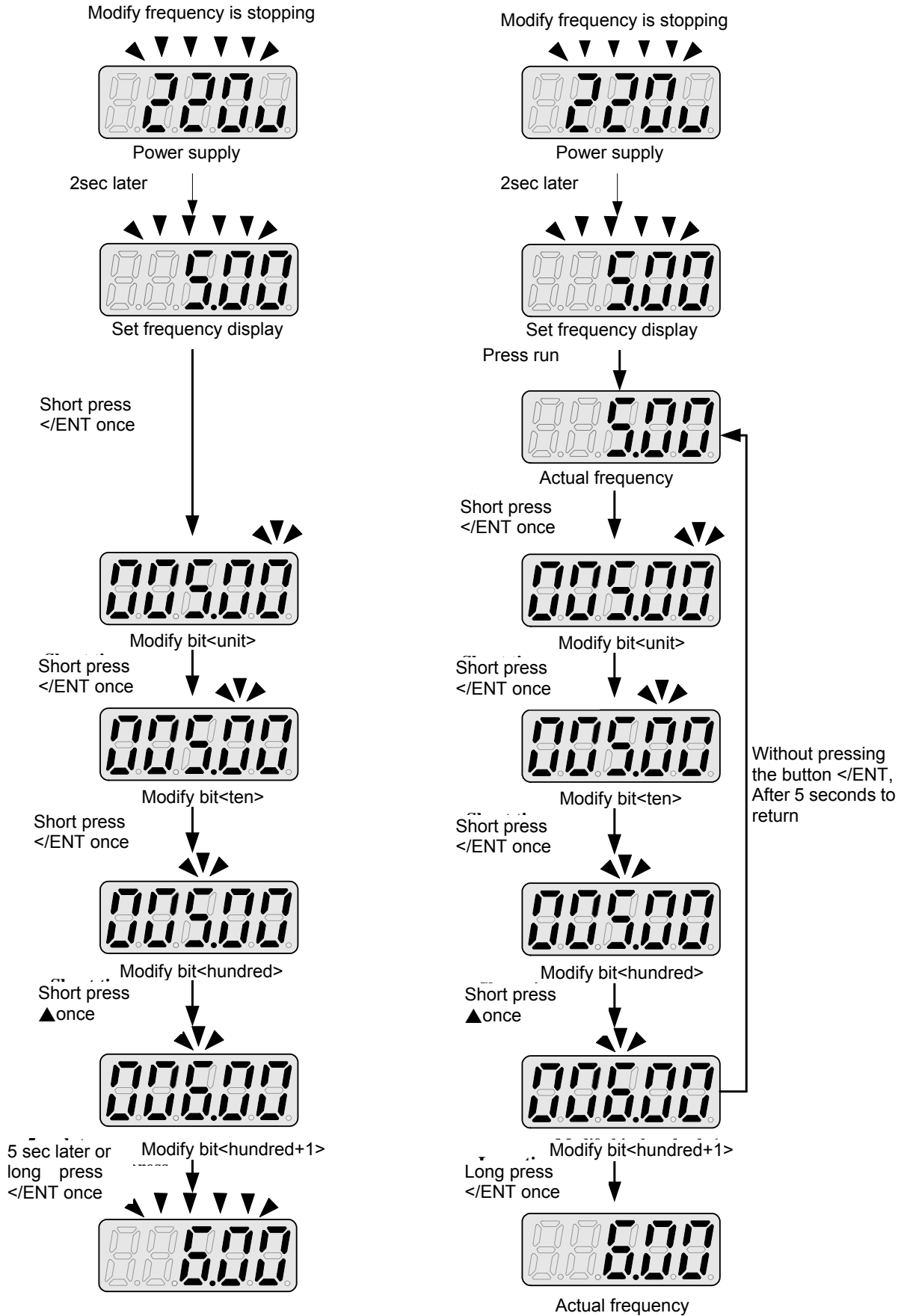

Note: frequency command setting will be limited to the range set by parameters for lower & upper frequency.

4.1.5 Operation Control

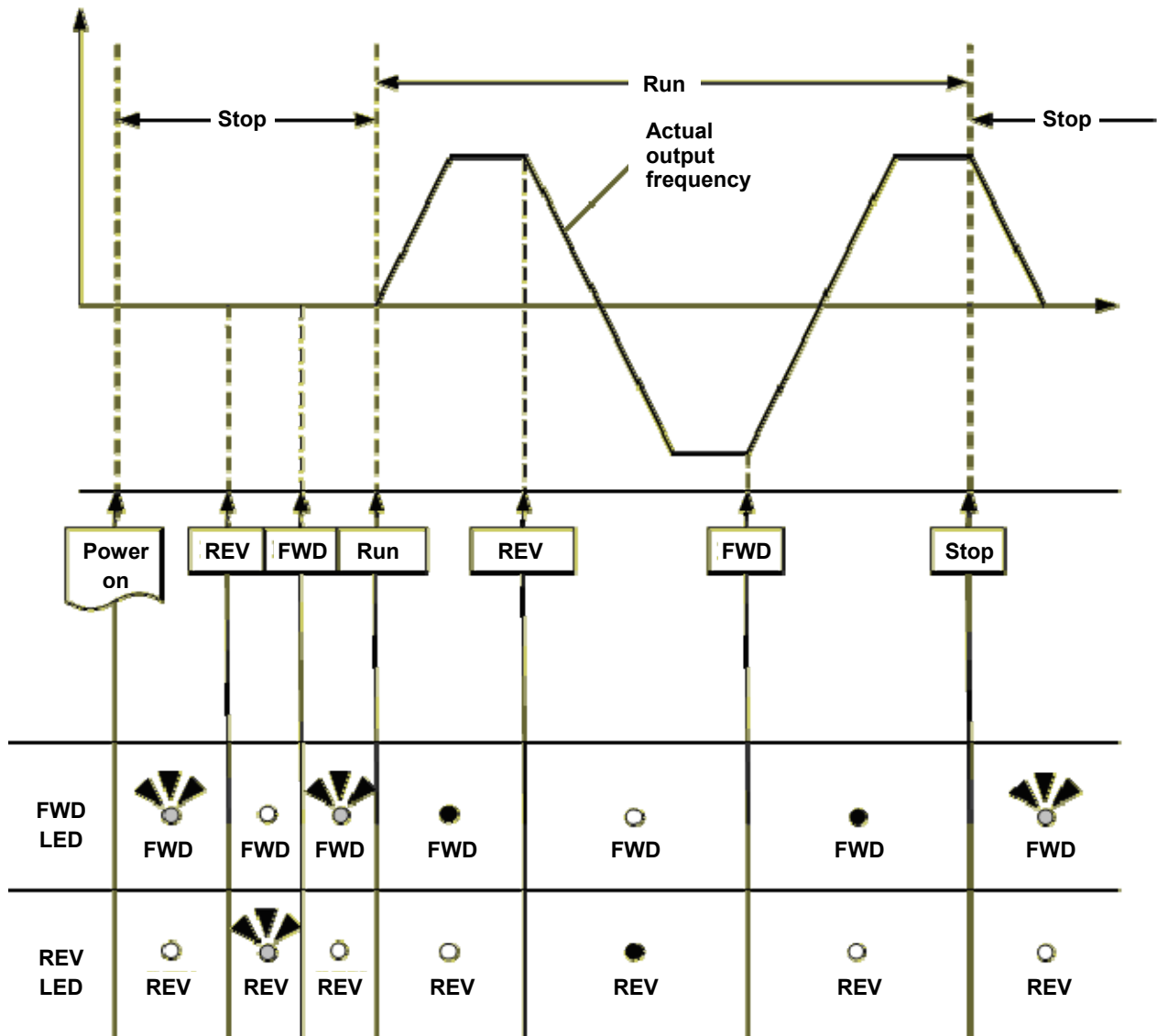

4.2 Programmable Parameter Groups

Parameter Group No.	Description
Group F	Simple function parameters
Group 00	Basic parameters
Group 01	V/F Pattern selections & setup
Group 02	Motor parameters
Group 03	Multi function digital Inputs/Outputs
Group 04	Analog signal inputs/ Analog output
Group 05	Preset Frequency Selections.
Group 06	Auto Run(Auto Sequencer) function
Group 07	Start/Stop command setup
Group 08	Drive and motor Protection
Group 09	Communication function setup
Group 10	PID function setup
Group 11	Performance control functions
Group 12	Digital Display & Monitor functions
Group 13	Inspection & Maintenance function

Parameter notes for Parameter Groups	
*1	Parameter can be adjusted during running mode
*2	Cannot be modified in communication mode
*3	Does not change with factory reset
*4	Read only

Group F- Simple function parameters group

No.	Description	Range	Factory Setting	Unit	Note
F01	Motor rotation	0:Forward 1:Reverse	0	-	*1
F02	Main Run Source Selection	0:Keypad 1:External Run/Stop Control 2:Communication	1	-	
F03	Operation modes for external terminals	0: Forward/Stop-Reverse/Stop 1: Run/Stop-Reverse/Forward 2: 3-Wire Control Mode-Run/Stop 3: 2-Wire self-holding Run/Stop	0	-	
F04	Main Frequency Source Selection	0:Keypad 1:Reserved 2:External AI Analog Signal Input 3:Reserved 4:External Up/Down Frequency Control 5:Communication setting Frequency 6:PID output frequency	2	-	
F05	Frequency Upper Limit	0.01~599.00	50.00/60.00	Hz	
F06	Frequency Lower Limit	0.00~598.99	0.00	Hz	
F07	Acceleration Time 1	0.1~3600.0	10.0	s	*1
F08	Deceleration Time 1	0.1~3600.0	10.0	s	*1
F09	Volts/Hz Patterns	1~7	1/4	-	
F10	Volts/Hz Curve Modification (Torque Boost)	0 ~ 10.0	0.0	%	*1
F11	Motor Rated Current (OL1)	----	by motor nameplate	A	
F12	Multifunction Input Term. S1	0: Forward/Stop Command 1: Reverse/Stop Command 2: Preset Speed setting bit 0 (5-02) 3: Preset Speed setting bit 1 (5-03) 4: Preset Speed setting bit 2 (5-05) 6: Jog Forward Command 7: Jog Reverse Command	0	-	
F13	Multifunction Input Term. S2	8: Up Command 9: Down Command 10: Second Acc/Dec time 11: Acc/Dec Disabled 12: Main/Alternative Run Command select	1	-	
F14	Multifunction Input Term. S3	13: Main/Alternative Frequency Command select 14: Rapid Stop (Decel to stop) 15: Base Block 16: Disable PID Function 17: Reset 18: Auto Run Mode enable	2	-	

F15	Output Relay(RY1)	0: Run 1: Fault 2: Setting Frequency Reached 3: Frequency Reached (3-13±3-14) 4: Output Frequency Detection1(>3-13) 5: Output Frequency Detection2(<3-13) 6: Auto-Restart 7: Momentary AC Power Loss 8: Rapid Stop 9: Base Block 10: Motor Overload Protection(OL1) 11: Drive Overload Protection(OL2) 12: Reserved 13: Output Current Reached 14: Brake Control 15: PID feedback disconnection detection 16~18: Reserved 19: Synchronize S1 20: Synchronize S2 21: Synchronize S3 22: Synchronize S4	1	-	
F16	Preset Speed 1	0.00 ~ 599.00	5.00	Hz	*1
F17	Preset Speed 2	0.00 ~ 599.00	10.00	Hz	*1
F18	Preset Speed 3	0.00 ~ 599.00	20.00	Hz	*1
F19	Momentary Power Loss and Restart	0: Momentary Power Loss and Restart disable 1: Momentary power loss and restart enable	0	s	
F20	Auto Restart Delay Time	0.0~6000.0	0.0	s	
F21	Number of Auto Restart Attempts	0~10	0	-	
F22	Direct Running After Power Up	0: Enable Direct run on power up 1: Disable Direct run on power up	1	-	
F23	DC Injection Brake Start Frequency (Hz) in Stop Mode	0.10 ~ 10.00	1.5	Hz	
F24	DC Injection Brake Level (%) in Stop Mode	0 ~ 20. Based on the 20% of maximum output voltage	5	%	
F25	DC Injection Brake Time (Seconds) in Stop Mode	0.0 ~ 25.5	0.5	s	
F26	Stopping Method	0: Deceleration to stop 1: Coast to stop	0		
F27	Electronic Motor Overload Protection Operation Mode	xxxx0: Disable Electronic Motor Overload Protection xxxx1: Enable Electronic Motor Overload Protection xxx0x: Motor Overload Cold Start xxx1x: Motor Overload Hot Start xx0xx: Standard Motor xx1xx: Invertor Duty Motor	00001	-	
F28	Reverse Operation Control	0: Reverse command is valid 1: Reverse command is invalid	0	-	
F29	Carrier Frequency (kHz)	1~16	5	KHz	
F30	Software Version	----	-	-	*3*4
F31	Fault Log (Last 3 Faults)	----	-	-	*3*4

F32	Restore Factory Settings	1150: Initialization (50Hz, 220V/380V) 1160: Initialization (60Hz, 220V/380V) 1250: Initialization (50Hz, 230V/400V) 1260: Initialization (60Hz, 230V/460V) 1350: Initialization (50Hz, 220V/415V) 1360: Initialization (60Hz, 230V/400V)	1250/1360 (Note)	-	
F33	Parameter Function Display	0: Simple Parameters Group 1: Complete Parameters Group	0		

Notes:

For built-in EMC filter models, the default setting of F32 is “1250”.

For without built-in EMC filter models, the default setting of F32 is “1360”

Group 00- The basic parameters group					
No.	Description	Range	Factory Setting	Unit	Note
00-00	control mode	0:V/F mode 1:Reserved	0	-	
00-01	Motor rotation	0:Forward 1:Reverse	0	-	*1
00-02	Main Run Source Selection	0:Keypad 1:External Run/Stop Control 2:Communication	1	-	
00-03	Alternative Run Source Selection	0:Keypad 1:External Run/Stop Control 2:Communication	0	-	
00-04	Operation modes for external terminals	0: Forward/Stop-Reverse/Stop 1: Run/Stop-Reverse/Forward 2: 3-Wire Control Mode-Run/Stop 3: 2-Wire self-holding Run/Stop	0	-	
00-05	Main Frequency Source Selection	0:Keypad 1:Reserved 2:External AI Analog Signal Input 3:Reserved 4:External Up/Down Frequency Control 5:Communication setting Frequency 6:PID output frequency	2	-	
00-06	Alternative Frequency Source Selection	0:Keypad 1:Reserved 2:External AI Analog Signal Input 3:Reserved 4:External Up/Down Frequency Control 5:Communication setting Frequency 6:PID output frequency.	0	-	
00-07	Main and Alternative Frequency Command modes	0: Main Or Alternative Frequency 1: Main frequency + Alternative Frequency	0	-	
00-08	Communication Frequency Command	0.00~599.00		Hz	*4
00-09	Frequency Command Save Mode	0:Save the frequency before power down 1:Save the communication frequency	0	-	
00-10	Initial Frequency Selection	0:by Current Frequency Command 1:by 0 Frequency Command 2:by 00-11	0	-	
00-11	Initial Frequency Command	0.00~599.00	50.00/60.00	Hz	
00-12	Frequency Upper Limit	0.01~599.00	50.00/60.00	Hz	
00-13	Frequency Lower Limit	0.00~598.99	0.00	Hz	
00-14	Acceleration Time 1	0.1~3600.0	10.0	s	*1
00-15	Deceleration Time 1	0.1~3600.0	10.0	s	*1
00-16	Acceleration Time 2	0.1~3600.0	10.0	s	*1
00-17	Deceleration Time 2	0.1~3600.0	10.0	s	*1
00-18	Jog Frequency	1.00~25.00	2.00	Hz	*1
00-19	Jog Acceleration Time	0.1~25.5	0.5	s	*1
00-20	Jog Deceleration Time	0.1~25.5	0.5	s	*1

Group 01- V/F Pattern selection & Setup					
No.	Description	Range	Factory Setting	Unit	Note
01-00	Volts/Hz Patterns	1~7	1/4	-	
01-01	V/F Max Voltage	200V:170.0~264.0 400V:323.0~528.0	Based on 13-08	Vac	
01-02	Max Frequency	0.2 ~ 599.00	50.00/60.00	Hz	
01-03	Max Frequency Voltage Ratio	0.0 ~ 100.0	100.0	%	
01-04	Mid Frequency 2	0.1 ~ 599.00	2.50/3.00	Hz	
01-05	Mid Frequency Voltage Ratio 2	0.0 ~ 100.0	7.5/6.8	%	
01-06	Mid Frequency 1	0.1 ~ 599.00	2.50/3.00	Hz	
01-07	Mid Frequency Voltage Ratio 1	0.0 ~ 100.0	7.5/6.8	%	
01-08	Min Frequency	0.1 ~ 599.00	1.30/1.50	Hz	
01-09	Min Frequency Voltage Ratio	0.0 ~ 100.0	4.5/3.4	%	
01-10	Volts/Hz Curve Modification (Torque Boost)	0 ~ 10.0	0.0	%	*1
01-11	V/F Start Frequency	0.00~10.00	0.00	Hz	
01-12	No-load Oscillation Suppression Gain	0.0~200.0	0	%	
01-13	Motor Hunting Prevention Coefficient	1~8192	800		
01-14	Motor Hunting Prevention Gain	0~100	0	%	
01-15	Motor Hunting Prevention Limit	0~100.0	5.0	%	
01-16	Auto-Torque Compensation Filter Coefficient	0.1~1000.0	0.1	ms	
01-17	Auto-torque Compensation Gain	0~100	0	%	
01-18	Auto-torque Compensation Frequency	1.30~5.00	2	Hz	

Group 02- Motor parameters

No.	Description	Range	Factory Setting	Unit	Note
02-00	Motor No Load Current	----	by motor nameplate	A	
02-01	Motor Rated Current (OL1)	----	by motor nameplate	A	
02-02	V/F Slip Compensation	0.0~200.0	0.0	%	*1
02-03	Motor Rated Speed	----	by motor nameplate	Rpm	
02-04	Motor Rated Voltage	----	by motor nameplate	Vac	
02-05	Motor Rated Power	0.1~dependent on the different horsepower	by motor nameplate	kW	
02-06	Motor Rated Frequency	0~599.0	by motor nameplate		
02-15	Low Frequency Torque Gain	0~100	50	%	

Group 03- Multi function Digital Inputs/Outputs

No.	Description	Range	Factory Setting	Unit	Note
03-00	Multifunction Input Term. S1	0: Forward/Stop Command 1: Reverse/Stop Command 2: Preset Speed setting bit 0 (5-02) 3: Preset Speed setting bit 1 (5-03) 4: Preset Speed setting bit 2 (5-05)	0	-	
03-01	Multifunction Input Term. S2	6: Jog Forward Command 7: Jog Reverse Command 8: Up Command 9: Down Command	1	-	
03-02	Multifunction Input Term. S3	10: Second Acc/Dec time 11: Acc/Dec Disabled 12: Main/Alternative Run Command select 13: Main/Alternative Frequency Command select	2	-	
03-03	Multifunction Input Term. S4	14: Rapid Stop (Decel to stop) 15: Base Block 16: Disable PID Function 17: Reset 18: Auto Run Mode enable	17	-	
03-06	Up/Down frequency band	0.00~5.00	0.00	Hz	
03-07	Up/Down Frequency modes	0: Preset frequency is held as the inverter stops, and UP/Down function is disabled. 1: Preset frequency is reset to 0 Hz as the inverter stops. 2: Preset frequency is held as the inverter stops, and the UP/Down is available.	0	-	
03-08	S1~S4 scan confirmation	1~200. Number of Scan cycles	10	2ms	
03-09	S1~ S4 switch type select	xxxx0:S1 NO xxx1:S1 NC xxx0x:S2 NO xxx1x:S2 NC xx0xx:S3 NO xx1xx:S3 NC x0xxx:S4 NO x1xxx:S4 NC	00000	-	
03-11	Output Relay(RY1)	0: Run 1: Fault 2: Setting Frequency Reached 3: Frequency Reached (3-13±3-14) 4: Output Frequency Detection1(> 3-13) 5: Output Frequency Detection2(< 3-13) 6: Auto-Restart 7: Momentary AC Power Loss 8: Rapid Stop 9: Base Block 10: Motor Overload Protection(OL1) 11: Drive Overload Protection(OL2) 12: Reserved 13: Output Current Reached 14: Brake Control 15: PID feedback disconnection detection 16~18: Reserved 19: Synchronize S1 20: Synchronize S2 21: Synchronize S3 22: Synchronize S4	1	-	

No.	Description	Range	Factory Setting	Unit	Note	
03-13	Output frequency detection level (Hz)	0.00~599.00	0.00	Hz	*1	
03-14	Frequency Detection band	0.00~30.00	2.00	Hz	*1	
03-15	Output Current Detection Level	0.1~999.9	0.1	A		
03-16	Output Current Detection Period	0.1~10.0	0.1	s		
03-17	External Braking Release Level	0.00~20.00	0.00	Hz		
03-18	External Braking Engage Level	0.00~20.00	0.00	Hz		
03-19	Relay Output function type	0: A (Normally open) 1: B (Normally close)	0	-		
03-20	Braking Transistor On Level	200V: 240.0~400.0V 400V: 500.0~800.0V	220/230V:	380	VDC	
			380/400V:	690		
			415/460V:	780		
03-21	Braking Transistor Off Level	200V: 240.0~400.0V 400V: 500.0~800.0V	220/230V:	360	VDC	
			380/400V:	650		
			415/460V:	740		

※ “NO” indicates normally open, “NC” indicates normally closed.

Group 04- Analog signal inputs/ Analogue output functions

No.	Description	Range	Factory Setting	Unit	Note
04-00	AVI/ACI analog Input signal type select	0: 0~10V/0~20mA 1: Reserved 2: Reserved 3: 2~10V/4~20mA	0	-	
04-01	AVI/ACI Signal Verification Scan rate	1~200	50	2ms	
04-02	AVI/ACI Gain	0~1000	100	%	*1
04-03	AVI/ACI Bias	0~100	0	%	*1
04-04	AVI/ACI Bias Selection	0: Positive 1: Negative	0	-	*1
04-05	AVI/ACI Slope	0: Positive 1: Negative	0	-	*1
04-11	Analog Output mode (AO)	0: Output Frequency 1: Frequency Command 2: Output Voltage 3: DC Bus Voltage 4: Motor Current	0	-	*1
04-12	Analog Output AO Gain (%)	0~1000	100	%	*1
04-13	Analog Output AO Bias (%)	0~100	0	%	*1
04-14	AO Bias Selection	0: Positive 1: Negative	0	-	*1
04-15	AO Slope	0: Positive 1: Negative	0	-	*1

Group 05- Preset Frequency Selections.

No.	Description	Range	Factory Setting	Unit	Note
05-00	Preset Speed Control mode Selection	0: Common Accel/Decel Accel/Decel 1 or 2 apply to all speeds 1: Individual Accel/Decel Accel/ Decel 0-7 apply to the selected preset speeds (Acc0/Dec0~ Acc7/Dec7)	0	-	
05-01	Preset Speed 0 (Keypad Freq)	0.00 ~ 599.00	5.00	Hz	*1
05-02	Preset Speed 1	0.00 ~ 599.00	5.00	Hz	*1
05-03	Preset Speed 2	0.00 ~ 599.00	10.00	Hz	*1
05-04	Preset Speed 3	0.00 ~ 599.00	20.00	Hz	*1
05-05	Preset Speed 4	0.00 ~ 599.00	30.00	Hz	*1
05-06	Preset Speed 5	0.00 ~ 599.00	40.00	Hz	*1
05-07	Preset Speed 6	0.00 ~ 599.00	50.00	Hz	*1
05-08	Preset Speed 7	0.00 ~ 599.00	50.00	Hz	*1
05-17	Preset Speed 0-Acctime	0.1 ~ 3600.0	10.0	s	*1
05-18	Preset Speed 0-Dectime	0.1 ~ 3600.0	10.0	s	*1
05-19	Preset Speed 1-Acctime	0.1 ~ 3600.0	10.0	s	*1
05-20	Preset Speed 1-Dectime	0.1 ~ 3600.0	10.0	s	*1
05-21	Preset Speed 2-Acctime	0.1 ~ 3600.0	10.0	s	*1
05-22	Preset Speed 2-Dectime	0.1 ~ 3600.0	10.0	s	*1
05-23	Preset Speed 3-Acctime	0.1 ~ 3600.0	10.0	s	*1
05-24	Preset Speed 3-Dectime	0.1 ~ 3600.0	10.0	s	*1
05-25	Preset Speed 4-Acctime	0.1 ~ 3600.0	10.0	s	*1
05-26	Preset Speed 4-Dectime	0.1 ~ 3600.0	10.0	s	*1
05-27	Preset Speed 5-Acctime	0.1 ~ 3600.0	10.0	s	*1
05-28	Preset Speed 5-Dectime	0.1 ~ 3600.0	10.0	s	*1
05-29	Preset Speed 6-Acctime	0.1 ~ 3600.0	10.0	s	*1
05-30	Preset Speed 6-Dectime	0.1 ~ 3600.0	10.0	s	*1
05-31	Preset Speed 7-Acctime	0.1 ~ 3600.0	10.0	s	*1
05-32	Preset Speed 7-Dectime	0.1 ~ 3600.0	10.0	s	*1

Group 06- Auto Run(Auto Sequencer) function

No.	Description	Range	Factory Setting	Unit	Note
06-00	Auto Run (sequencer) mode selection	0: Disabled. 1: Single cycle. (Continues to run from the Unfinished step if restarted). 2: Periodic cycle. (Continues to run from the unfinished step if restarted). 3: Single cycle, then holds the speed Of final step to run. (Continues to run from the unfinished step if restarted). 4: Single cycle. (Starts a new cycle if restarted). 5: Periodic cycle. (Starts a new cycle if restarted). 6: Single cycle, then hold the speed of final step to run (Starts a new cycle if restarted).	0	-	
06-01	Auto _ Run Mode frequency command 1	0.00~599.00	0.00	Hz	*1
06-02	Auto _ Run Mode frequency command 2	0.00~599.00	0.00	Hz	*1
06-03	Auto _ Run Mode frequency command 3	0.00~599.00	0.00	Hz	*1
06-04	Auto _ Run Mode frequency command 4	0.00~599.00	0.00	Hz	*1
06-05	Auto _ Run Mode frequency command 5	0.00~599.00	0.00	Hz	*1
06-06	Auto _ Run Mode frequency command 6	0.00~599.00	0.00	Hz	*1
06-07	Auto _ Run Mode frequency command 7	0.00~599.00	0.00	Hz	*1
06-16	Auto _ Run Mode running time setting 0	0.0 ~ 3600.0	0.0	s	*1
06-17	Auto _ Run Mode running time setting 1	0.0 ~ 3600.0	0.0	s	*1
06-18	Auto _ Run Mode running time setting 2	0.0 ~ 3600.0	0.0	s	*1
06-19	Auto _ Run Mode running time setting 3	0.0 ~ 3600.0	0.0	s	*1
06-20	Auto _ Run Mode running time setting 4	0.0 ~ 3600.0	0.0	s	*1
06-21	Auto _ Run Mode running time setting 5	0.0 ~ 3600.0	0.0	s	*1
06-22	Auto _ Run Mode running time setting 6	0.0 ~ 3600.0	0.0	s	*1
06-23	Auto _ Run Mode running time setting 7	0.0 ~ 3600.0	0.0	s	*1
06-32	Auto _ Run Mode running direction 0	0: Stop 1: Forward 2: Reverse	0	-	
06-33	Auto _ Run Mode running direction 1	0: Stop 1: Forward 2: Reverse	0	-	
06-34	Auto _ Run Mode running direction 2	0: Stop 1: Forward 2: Reverse	0	-	
06-35	Auto _ Run Mode running direction 3	0: Stop 1: Forward 2: Reverse	0	-	

Group 06- Auto Run(Auto Sequencer) function

No.	Description	Range	Factory Setting	Unit	Note
06-36	Auto_ Run Mode running direction 4	0: Stop 1: Forward 2: Reverse	0	-	
06-37	Auto_ Run Mode running direction 5	0: Stop 1: Forward 2: Reverse	0	-	
06-38	Auto_ Run Mode running direction 6	0: Stop 1: Forward 2: Reverse	0	-	
06-39	Auto_ Run Mode running direction 7	0: Stop 1: Forward 2: Reverse	0	-	

Group 07- Start/Stop command setup

No.	Description	Range	Factory Setting	Unit	Note
07-00	Momentary Power Loss and Restart	0: Momentary Power Loss and Restart disable 1: Momentary power loss and restart enable	0	s	
07-01	Auto Restart Delay Time	0.0~6000.0	0.0	s	
07-02	Number of Auto Restart Attempts	0~10	0	-	
07-03	Reset Mode Setting	0: Enable Reset Only when Run Command is Off 1: Enable Reset when Run Command is On or Off	0	-	
07-04	Direct Running After Power Up	0: Enable Direct run on power up 1: Disable Direct run on power up	1	-	
07-05	Delay-ON Timer	1.0~300.0	1.0	s	
07-06	DC Injection Brake Start Frequency (Hz) in Stop Mode	0.10 ~ 10.00	1.5	Hz	
07-07	DC Injection Brake Level (%) in Stop Mode	0 ~ 20. Based on the 20% of maximum output voltage	5	%	
07-08	DC Injection Brake Time (Seconds) in Stop Mode	0.0 ~ 25.5	0.5	s	
07-09	Stopping Method	0: Deceleration to stop 1: Coast to stop	0		
07-10	DC Braking Level at Start	0 ~ 20. Based on the 20% of maximum output voltage	0	%	
07-11	DC Braking Time at Start	0.0~25.5	0.0	s	
07-12	Run Command Retention	0: Run command retention during power loss 1: Run command not retained during power loss	1		

Group 08- Drive & Motor Protection functions					
No.	Description	Range	Factory Setting	Unit	Note
08-00	Trip Prevention Selection	xxxx0: Enable Trip Prevention During Acceleration xxxx1: Disable Trip Prevention During Acceleration xxx0x: Enable Trip Prevention During Deceleration xxx1x: Disable Trip Prevention During Deceleration xx0xx: Enable Trip Prevention in Run Mode xx1xx: Disable Trip Prevention in Run Mode x0xxx: Enable over voltage Prevention in Run Mode x1xxx: Disable over voltage Prevention in Run Mode	00000	-	
08-01	Trip Prevention Level During Acceleration (%)	50 ~ 200	by series	Inverter Rated Current 100%	
08-02	Trip Prevention Level During Deceleration (%)	50 ~ 200	by series		
08-03	Trip Prevention Level In Run Mode (%)	50 ~ 200	by series		
08-04	over voltage Prevention Level in Run Mode	200V: 350.0~390.0 400V: 700.0~780.0	380.0/760.0	VDC	*1
08-05	Electronic Motor Overload Protection Operation Mode	xxxx0: Disable Electronic Motor Overload Protection xxxx1: Enable Electronic Motor Overload Protection xxx0x: Motor Overload Cold Start xxx1x: Motor Overload Hot Start xx0xx: Standard Motor xx1xx: Inverter Duty Motor	00001	-	
08-06	Operation After Overload Protection is Activated	0: Coast-to-Stop After Overload Protection is Activated 1: Drive Will Not Trip when Overload Protection is Activated (OL1)	0	-	
08-07	Over heat Protection (cooling fan control)	0: Auto (Depends on temp.) 1: Operate while in RUN mode 2: Always Run 3: Disabled	1	-	
08-08	AVR Function (Auto Voltage Regulation)	0: AVR function enable 1: AVR function Disable 2: AVR function disable for stop 3: AVR function disable for deceleration 4: AVR function disable for stop and deceleration. 5: When VDC>(360V/740V), AVR function disable for stop and deceleration.	4	-	
08-09	Input phase lost protection	0: Disabled 1: Enabled	0	-	
08-10	PTC Overheat Function	0: Disable 1: Decelerate to stop 2: Coast to stop 3: Continue running, when warning level is reached. Coast to stop, when protection level is reached.	0		
08-11	PTC Signal Smoothing Time	0.01~10.00	0.2	Sec	

Group 08- Drive & Motor Protection functions					
No.	Description	Range	Factory Setting	Unit	Note
08-12	PTC Detection Time Delay	1~300	60	Sec	
08-13	PTC Protection Level	0.1~10.0	0.7	V	
08-14	PTC Detection Level Reset	0.1~10.0	0.3	V	
08-15	PTC Warning Level	0.1~10.0	0.5	V	
08-16	Fan Control Temperature Level	10.0~50.0	50.0	°C	
08-17	Over current protection level	0.0 ~ 60.0	0.0	A	
08-18	Over current protection time	0.0 ~ 1500.0	1.0	s	
08-19	Motor Overload Protection Level	0: Motor Overload Protection Level 0 1: Motor Overload Protection Level 1 2: Motor Overload Protection Level 2	0		

Group 09- Communication function setup					
No.	Description	Range	Factory Setting	Unit	Note
09-00	Assigned Communication Station Number	1 ~ 32	1	-	*2*3
09-01	Communication Mode Select	0: Modbus RTU code 1: Modbus ASCII code	0	-	*2*3
09-02	Baud Rate Setting (bps)	0: 4800 1: 9600 2: 19200 3: 38400	2	bps	*2*3
09-03	Stop Bit Selection	0: 1 Stop Bit 1: 2 Stop Bits	0	-	*2*3
09-04	Parity Selection	0: Without Parity 1: With Even Parity 2: With Odd Parity	0	-	*2*3
09-05	Data Format Selection	0: 8-Bits Data 1: 7-Bits Data	0	-	*2*3
09-06	Communication time-out detection time	0.0 ~ 25.5	0.0	s	
09-07	Communication time-out operation selection	0: Deceleration to stop (set by 00-15) 1: Coast to stop 2: Deceleration to stop (set by 00-17) 3: continue operating	0	-	
09-08	Error 6 verification time.	0 ~ 20	3		
09-09	Drive Transmit delay Time (ms)	5 ~ 65	5	2 ms	

Group10- PID function Setup

No.	Description	Range	Factory Setting	Unit	Note
10-00	PID target value selection (when 00-05\00-06=6, this function is enabled)	0: Reserved 1: Analog Signal Input. (AVI/ACI) 2: Reserved 3: Frequency set by communication 4: 10-02 given 5: Preset frequency	1	-	*1
10-01	PID feedback value selection	0: Reserved 1: Analog Signal Input. (AVI/ACI) 2: Reserved 3: Communication Setting Frequency	3	-	*1
10-02	PID Target (keypad input)	0.0~100.0	50.0	%	*1
10-03	PID Mode Selection	0: Disabled. 1: Deviation D Control. FWD Characteristic. 2: Feedback D Control. FWD Characteristic 3: Deviation D Control. Reverse Characteristic. 4: Feedback D Control. Reverse Characteristic 5: Frequency Command + Deviation D Control. FWD Characteristic 6: Frequency Command + Feedback D Control FWD Characteristic. 7: Frequency Command + Deviation D Control Reverse Characteristic. 8: Frequency Command + Feedback D Control Reverse Characteristic	0	-	
10-04	Feedback Gain Coefficient	0.00 ~ 10.00	1.00	%	*1
10-05	Proportional Gain	0.0 ~ 10.0	3.0	%	*1
10-06	Integral Time	0.0 ~ 100.0	0.5	s	*1
10-07	Derivative Time	0.00 ~ 10.00	0.00	s	*1
10-08	PID Offset	0: Positive 1: Negative	0	-	*1
10-09	PID Offset Adjust	0 ~ 109	0	%	*1
10-10	PID Output Lag Filter Time	0.0 ~ 2.5	0.0	s	*1
10-11	Feedback Loss Detection Mode	0: Disabled 1: Drive keeps running after feedback loss 2: Drive stops after feedback loss	0	-	
10-12	Feedback Loss Detection Level	0 ~ 100	0	%	
10-13	Feedback Loss Detection Delay Time	0.0 ~25.5	1.0	s	
10-14	Integration Limit Value	0 ~ 109	100	%	*1
10-15	Integral Value Resets to Zero when Feedback Signal Equals the Target Value	0 ~ 30 0: Disabled 1: 1 Second 30: 30 Seconds	0	-	
10-16	Allowable Integration Error. Margin (units)(1unit = 1/8192)	0 ~ 100	0	-	
10-17	PID Sleep Frequency Level	0.00~599.00	0.00	Hz	
10-18	PID Sleep Function Delay Time	0.0 ~25.5	0.0	s	
10-19	PID Wake up frequency Level	0.00 ~ 599.00	0.00	Hz	
10-20	PID Wake up function Delay Time	0.0 ~ 25.5	0.0	s	
10-21	Max PID Feedback Setting	0 ~999	100	-	*1
10-22	Min PID Feedback Setting	0 ~999	0	-	*1

Group11- Performance Control functions

No.	Description	Range	Factory Setting	unit	Note
11-00	Reverse operation control	0: Reverse command is valid 1: Reverse command is invalid	0	-	
11-01	Carrier Frequency (kHz)	1~16	5	KHz	
11-02	Carrier mode Selection	0: Mode0, 3phase PWM modulation 1: Mode1, 2phase PWM modulation 2: Mode2, random PWM modulation	1	-	
11-03	Carrier Frequency Reduction by Temperature Rise	0: Disabled 1: Enabled	0	-	
11-04	S-Curve Acc 1	0.0~4.0	0.00	s	
11-05	S-Curve Acc 2	0.0~4.0	0.00	s	
11-06	S-Curve Dec 3	0.0~4.0	0.00	s	
11-07	S-Curve Dec 4	0.0~4.0	0.00	s	
11-08	Skip Frequency 1	0.00~599.00	0.00	Hz	*1
11-09	Skip Frequency 2	0.00~599.00	0.00	Hz	*1
11-10	Skip Frequency 3	0.00~599.00	0.00	Hz	*1
11-11	Skip Frequency Bandwidth (±)	0.00~30.00	0.00	Hz	*1
11-13	Regeneration Prevention Function	0: Disable 1: Enable 2: Enable (during constant speed only)	0	-	
11-14	Regeneration Prevention Voltage Level	200v: 300.0~400.0 400v: 600.0~800.0	380/760	V	
11-15	Regeneration Prevention Frequency Limit	0.00~15.00	3.00	Hz	
11-16	Regeneration Prevention Voltage Gain	0~200	100	%	
11-17	Regeneration Prevention Frequency Gain	0~200	100	%	
11-21	Stop Key Selection	0: Enable Stop Key when Run Command not from Keypad 1: Disable Stop Key when Run Command not from Keypad	0		

Group12 Digital Display & Monitor functions

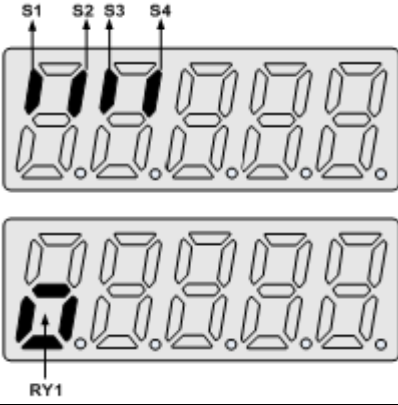
No.	Description	Range	Factory Setting	Unit	Note
12-00	Extended Display Mode	00000~66666. Each digit can be set to 0 to 6 0: Default display(frequency & parameters) 1:Output Current 2:Output Voltage 3:DC voltage 4:Temperature of Heat sink 5:PID feedback 6:Analog Signal Input. (AVI/ACI)	00321	-	*1
12-01	PID Feedback Display format	0: Integer (xxx) 1: One decimal Place (xx.x) 2: Two Decimal Places (x.xx)	0	-	*1
12-02	PID Feedback Display Unit Setting	0: xxx-- 1: xxxpb (pressure) 2: xxxfl (flow)	0	-	*1
12-03	Custom Units (Line Speed) Value	0~65535	1500/1800	RPM	*1
12-04	Custom Units (Line Speed) Display Mode	0:Drive Output Frequency is Displayed 1:Line Speed, Integer.(xxxxx) 2:Line Speed, One Decimal Place (xxxx.x) 3:Line Speed, Two Decimal Places (xxx.xx) 4:Line Speed, Three Decimal Places (xx.xxx)	0	-	*1
12-05	Inputs and output Logic status display (S1 to S4) & RY1		----	-	*4
12-06	Output Power	----	0.0	kW	
12-07	Motor Current Percentage	----	0	%	

Group 13 Inspection & Maintenance functions

No.	Description	Range	Factory Setting	unit	Note
13-00	Drive Horsepower Code	----	-	-	*3
13-01	Software Version	----	-	-	*3*4
13-02	Fault Log (Last 3 Faults)	----	-	-	*3*4
13-03	Accumulated Operation Time1 1	0~23	-	hour	*3*4
13-04	Accumulated Operation Time1 2	0~65535	----	day	*3*4
13-05	Accumulated Operation Time Mode	0: Time Under Power 1: Run Mode Time Only	0	-	*3
13-06	Parameter Lock	0: Enable all Functions 1: Preset speeds 05-01~05-08 cannot be changed 2: All Functions cannot be changed except for Preset speeds 05-01~05-08 3: Disable All Function	0	-	
13-07	Parameter Lock Code	00000~65535	00000	-	
13-08	Restore Factory Settings	1150: Initialization (50Hz, 220V/380V) 1160: Initialization (60Hz, 220V/380V) 1250: Initialization (50Hz, 230V/400V) 1260: Initialization (60Hz, 230V/460V) 1350: Initialization (50Hz, 220V/415V) 1360: Initialization (60Hz, 230V/400V)	1250/1360 (Note)	-	
13-09	Parameter Function Display	0: Complete Parameters Group 1: Simple Parameters Group	1		

Notes:

For built-in EMC filter models, the default setting of 13-08 is “1250”.

For without built-in EMC filter models, the default setting of 13-08 is “1360”

4.3 Parameter Function Description

F- Simple function parameters group

- Group F is a simple parameter setting group, which provides users with commonly used parameter settings and set them as factory defaults.

F33	Parameters Function Display
Range	[0] : Simple Parameters Group [1] : Complete Parameters Group

- Use F33 parameter to switch between simple parameters group (Default, F33=0) and complete parameters group (F33=1).
- Use 13-09 parameter to switch between complete parameter group (13-09=0) and simple parameters group (Default, 13-09=1).
- The simple parameters corresponds to the complete parameters relationship as shown in the following table:

Simple Parameters	Corresponding to Complete parameters	Simple Parameters	Corresponding to Complete parameters
F01	00-01	F17	05-03
F02	00-02	F18	05-04
F03	00-04	F19	07-00
F04	00-05	F20	07-01
F05	00-12	F21	07-02
F06	00-13	F22	07-04
F07	00-14	F23	07-06
F08	00-15	F24	07-07
F09	01-00	F25	07-08
F10	01-10	F26	07-09
F11	02-01	F27	08-05
F12	03-00	F28	11-00
F13	03-01	F29	11-01
F14	03-02	F30	13-01
F15	03-11	F31	13-02
F16	05-02	F32	13-08

F01	Motor Direction Control
Range	[0] : Forward [1] : Reverse

- F01 is valid in key pad mode only.
- ※Note: When Reverse function is disabled by parameter F28=1 setting F01 to 1 ." LOC" will be displayed

F02	Main Run Command Source selection
Range	[0] : Keypad [1] : External Run/Stop Control [2] : Communication

- Parameter F02 sets the inverter operation command source.

F03	Operation modes for external terminals
Range	[0] : Forward/stop-reverse/stop [1] : Run/stop-forward/reverse [2] : 3-wire control mode run/stop [3] : 2-wire self-holding run/stop

➤ Parameter F03 sets the function of the External Run/Stop and it is used in conjunction with parameters.

F02 (Main Run Source)=1, the command comes from External Run /Stop)

Parameters F12 to F14, which are used to set the required function for the digital inputs [S1 to S3] (multi-function inputs).

Note1: Parameters F12 to F14 are only required for External Run/stop
(Two wire control mode).

Note2: For External Run /Stop control set parameters in the following order:

1. F02
2. F03
3. F12 to F14 as required. Not required for three wire control mode.

When F03=0

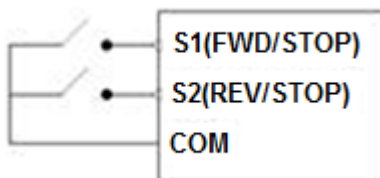

Two external switches are required, one for forward direction and the other for reverse.
Switch type: two position, maintained type. (This is two wire mode).

1. Forward (Run/Stop) Switch

Select one of the multifunction inputs [S1 to S3] and set the relevant parameter F12 to F14= 0 (Forward run /Stop mode.)

2. Reverse (Run/Stop) Switch

Select one of the multifunction inputs [S1 to S3] and set the relevant parameter F12 to F14= 1 (Reverse run /Stop mode.)

When F03= 1

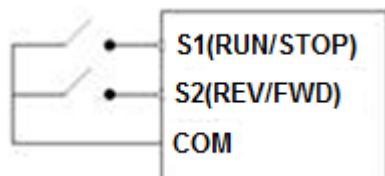

Two external switches are required.

Switch type: two position, maintained type. (This is two wire mode).

1. Run/Stop switch

Select one of the multifunction inputs [S1 to S3] and set the relevant parameter F12 to F14= 0 (Run/Stop mode.)

2. Forward/Reverse Switch

Select one of the multifunction inputs [S1 to S3] and set the relevant parameter F12 to F14= 1 (Forward/ Reverse direction selection.)

Switch in OFF position = Forward direction

Switch in ON position = Reverse direction

When F03= 2. Three Wire Control mode Run/Stop

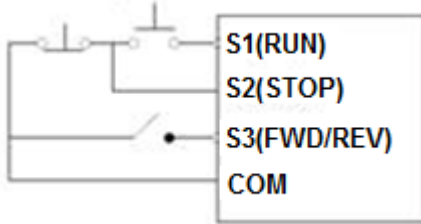

In this mode, two separated momentary push buttons are used for start and stop functions.

In this mode, parameter group 03 for S1 to S3 are not effective.

S1, S2 and S3 are allocated automatically.

Note: For S1 to initiate the Run command. Push button connected to S2 must be connected by a normally closed type contact (NC).

When F03= 3, Two wire self-holding RUN/STOP

Please see the wiring diagram and timing chart below.

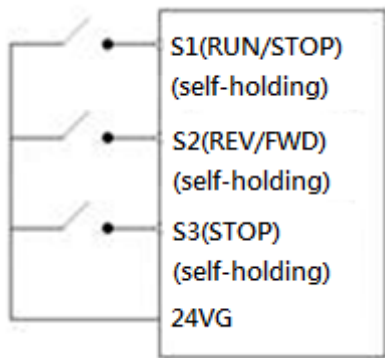

(Wiring diagram)

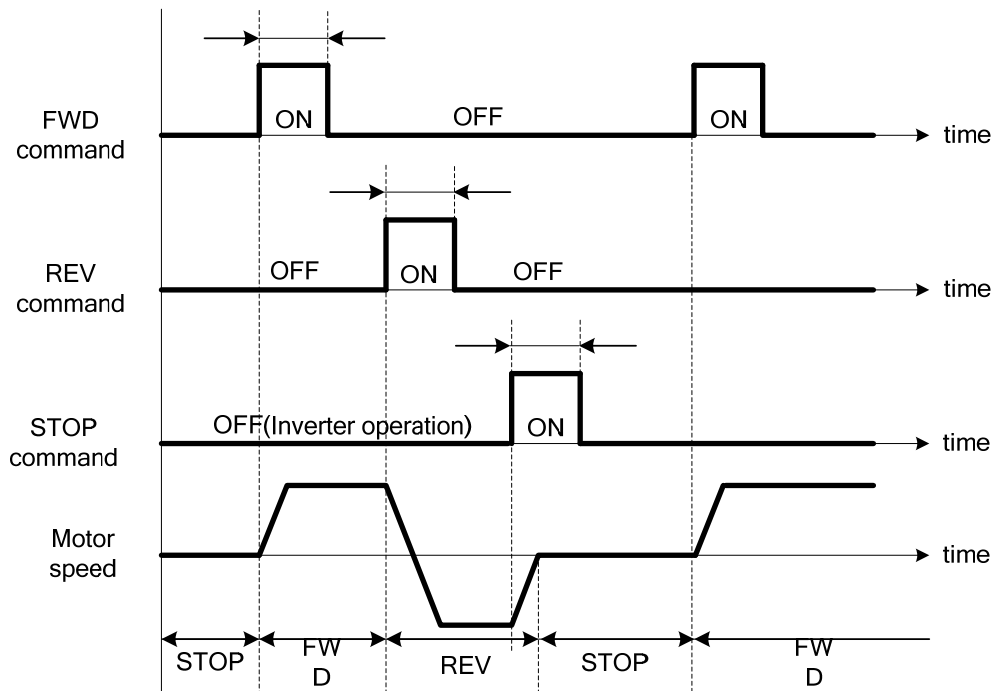

(Timing chart)

F04	Main Frequency Command Source Selection
Range	[0] : UP/DOWN of Keypad [1] : Reserved [2] : External AI Analog Signal Input [3] : Reserved [4] : External Up/Down Frequency Control [5] : Communication setting Frequency [6] : PID Output frequency

- Use F04 to select the source of the frequency command.

F05	Frequency Upper limit
Range	[0.01~599.00] Hz
F06	Frequency Lower limit
Range	[0.00~598.99] Hz

- When F06 and the command frequency are both set to 0.00, if RUN is pressed "Stop" is displayed.
- When Frequency command is > than preset in F06 inverter output will ramp up from 0.00 to the command frequency.
- When F06 > 0, and the frequency command value ≤ F06, inverter output will ramp up from preset in lower limit to the command frequency.

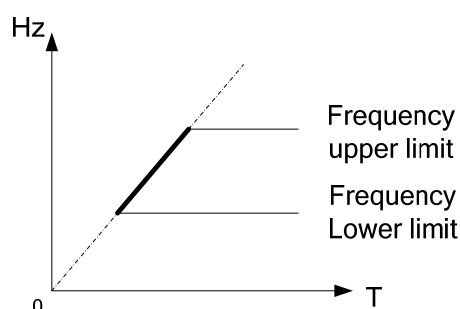

F07	Acceleration time 1
Range	[0.1~3600.0] s
F08	Deceleration time 1
Range	[0.1~3600.0] s

- Preset Acceleration and Deceleration times by above parameters are the time taken for the output frequency to ramp up or ramp down between the Upper and the lower V/F frequency limits.
- Actual acceleration and deceleration time is calculated as follows:

$$\text{Actual acceleration time} = \frac{(F07) \times (\text{set frequency} - \text{the minimum starting frequency})}{V/F \text{ Maximum output frequency}}$$

$$\text{Actual deceleration time} = \frac{(F08) \times (\text{set frequency} - \text{the minimum starting frequency})}{V/F \text{ Maximum output frequency}}$$

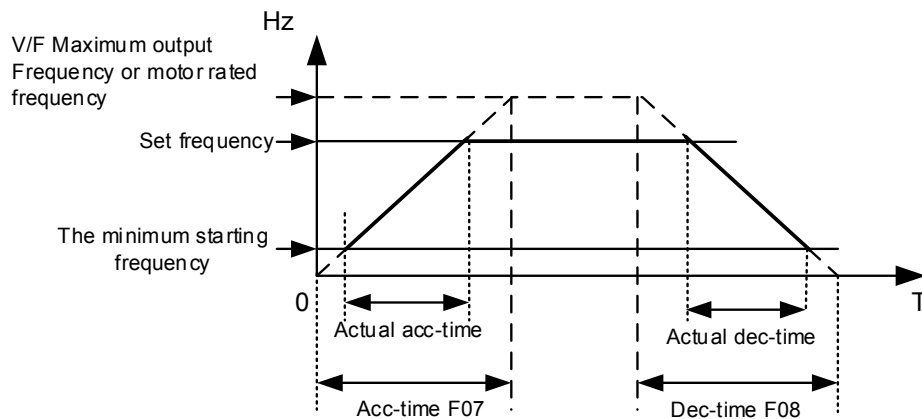

V/F Maximum output frequency is for VF curve, which can be checked from table when VF curve is fixed. Maximum output frequency is 01-02 when VF curve is customized, or motor rated frequency 02-06

F09	Volts/Hz Patterns (V/F)
Range	【1~7】

- Set F09 to one of the following preset V/f selections 【1~6】 according to the required application.
- Parameters 01-02~01-09 can not be modified (read only).
- Six fixed V/f patterns are shown below. 【1~3】 for 50 Hz systems and 【4~6】 for 60 Hz.

TYPE	50Hz		60Hz	
Function	01-00	V/F pattern	01-00	V/F pattern
General Use	【1】		【4】	
High start torque	【2】		【5】	
Decreasing torque	【3】		【6】	

- (V) 100% is the maximum output voltage. B, C point preset % settings will be as table below:-

F09	B(Xb)	C(Xc)
1/4	7.5%	4.5%
2/5	10%	7%
3/6	25%	7.7%

- Setting F09= [7] provides a flexible V/F curve which can be selected by experienced users by setting parameters (01-02~01-09).

F10	Volts/Hz Curve Modification (Torque Boost)
Range	[0 ~ 10.0] %

- Inverter output V / F curve settings for points B, C can be adjusted by parameter F10 to improve the output torque.
- Calculation of B, C point voltage: B point voltage = Xb × maximum output voltage, C point voltage = Xc × maximum output voltage (Xb, Xc see the description of F09). When F10 = 0, the torque improvement is disabled.

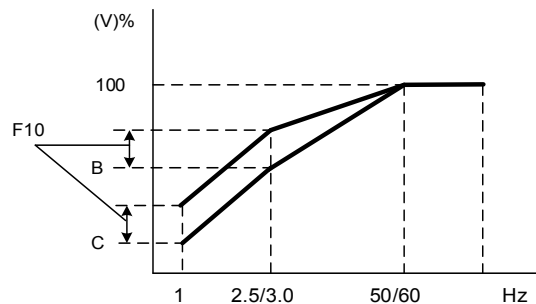

F11	Motor Rated Current
Range	----

※Note: Parameters F11 have to be set according to the specific motor data and in relation to the Inverter rating model parameter (13- 00).

F12	Multifunction Input Term. S1
F13	Multifunction Input Term. S2
F14	Multifunction Input Term. S3
Range	<p>[0] :Forward/Stop Command------(Parameters 00- 02/00-03=1 & 00-04)</p> <p>[1] :Reverse/Stop Command------(Parameters 00-02/00-03=1 & 00-04)</p> <p>[2] :Preset Speed setting bit 0 (5- 02)------(Parameter Group5)</p> <p>[3] :Preset Speed setting bit 1 (5- 03)------(Parameter Group5)</p> <p>[4] :Preset Speed setting bit 2 (5- 05) ------(Parameter Group5)</p> <p>[6] :JOG Forward Command------(Parameters 00-18~00-20)</p> <p>[7] :JOG Reverse Command------(Parameters 00-18~00-20)</p> <p>[8] :Up Command----- (Parameters 00- 05/00- 06=4& 03-06/03-07)</p> <p>[9] :Down Command----- (Parameters 00- 05/00- 06=4& 03-06/03-07)</p> <p>[10] : Second Acc/Dec time</p> <p>[11] : Disable Acc/Dec</p> <p>[12] : Main/ Alternative run source Select------(Parameters 00- 02/00- 03)</p> <p>[13] : Main/Alternative Frequency Command Select----(Parameters 00- 05/00- 06)</p> <p>[14] : Rapid Stop (controlled deceleration stop)</p>

<p>[15] : Base Block (Coast to stop) [16] : Disable PID Function.-----(Parameter Goup10) [17] : Reset [18] : Enable Auto Run Mode----- (Parameter Group 6)</p>

1) For setting parameters F12 ~ F14 to [0, 1] External Run/Stop Control, refer to F03.

A. 2-wire method. Mode 1.

Example: FWD/STOP and REV/STOP from two inputs (S1&S2)

Set F03= [0] , S1: F12= [0] (FWD/STOP) , S2: F13= [1] (REV/STOP);

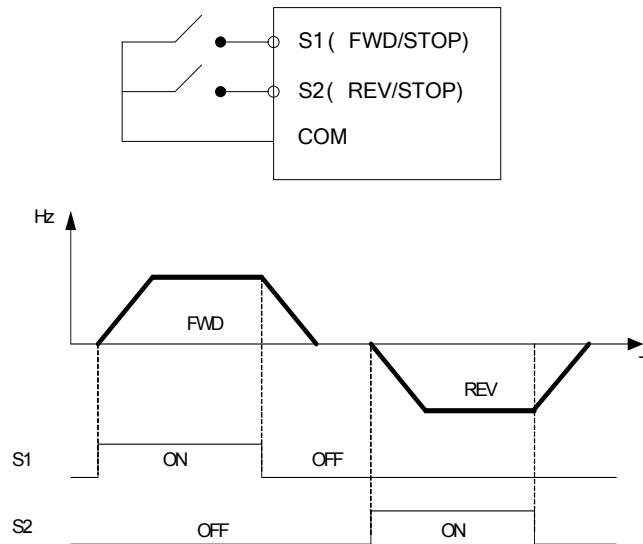

※ **Note:** If both forward and reverse commands are ON, it will be treated as a STOP signal.

B. 2-wire method. Mode 2.

Example: RUN/STOP and REV/FWD from two inputs (S1&S2)

Set F03= [1] ; S1: F12= [0] (RUN/STOP); S2: F13= [1] (REV/FWD);

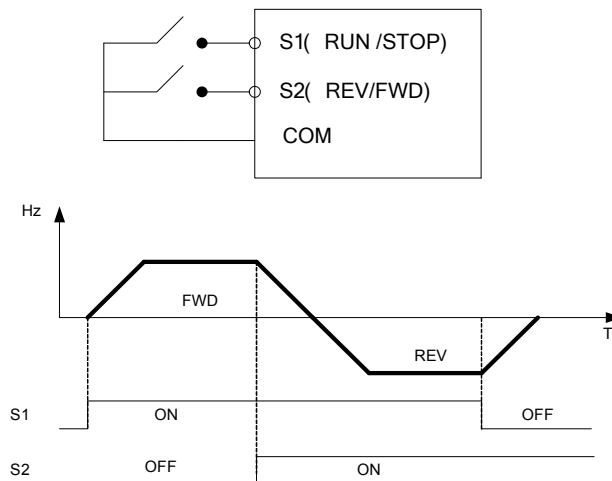

C. 3-wire method.

Example: Two separate push buttons for RUN & STOP and a two position switch for FWD/ REV

Set F03=2 (3 wire control mode), then terminals S1, S2 and S3 are dedicated to this function and preset selections for parameters F12, F13 and F14. are not relevant.

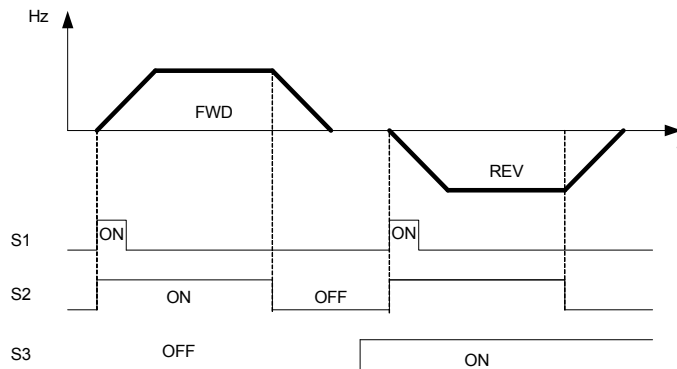
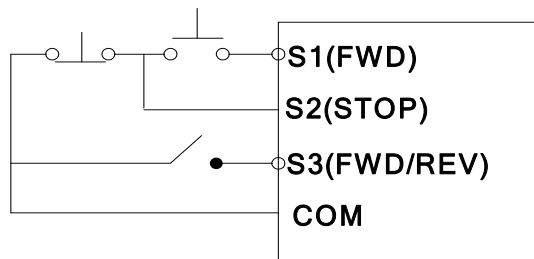

Note: More information about F12~F14, please refer to the contents of 03-00

F15	Multifunction Output Relay RY1 functions. (Terminals RA, RB)
Range	<p>【0】 :Run</p> <p>【1】 :Fault</p> <p>【2】 :Setting Frequency Reached -----(refer to 03-14)</p> <p>【3】 :Frequency Reached (3-13±3-14) -----(refer to 03-13/03-14)</p> <p>【4】 :Output Frequency Detection 1 (> 03-13) -----(refer to 03-13)</p> <p>【5】 :Output Frequency Detection 2 (< 03-13) -----(refer to 03-13)</p> <p>【6】 :Auto-Restart</p> <p>【7】 :Momentary AC Power Loss----- (refer to 07-00)</p> <p>【8】 :Rapid Stop (Decelerate to Stop)</p> <p>【9】 :Base Block</p> <p>【10】 :Motor Overload Protection (OL1)</p> <p>【11】 :Drive Overload Protection (OL2)</p> <p>【13】 :Output Current Reached -----(refer to 03-15/03-16)</p> <p>【14】 :Brake Control----- (refer to 03-17/03-18)</p> <p>【15】 :PID Feedback Disconnection Detection -----(refer to 10-11/10-13)</p>

Output relay RY1, function descriptions:

- 1) F15 = 【0】 . RY1 will be ON with run signal.
- 2) F15 = 【1】 . RY1 will be ON with inverter faults.
- 3) F15 = 【2】 . RY1 will be ON when output frequency reached setting frequency.

Note: More information about F15, please refer to the contents of 03-11

F16	Preset Speed 1
F17	Preset Speed 2
F18	Preset Speed 3
Range	【0.00 ~ 599.00】 Hz

F19	Momentary power loss and restart
Range	<p>【0】 :Momentary Power Loss and Restart disable</p> <p>【1】 :Momentary power loss and restart enable</p>

- If the input power supply due to sudden increase in supply demand by other equipment results in voltage drops below the under voltage level, the inverter will stop its output at once.
- When F19, on power loss, the inverter will not start.
- When F19=1, after a momentary power loss, inverter will restart with the same frequency before power loss, and there is no limitation on number of restarts.
- On power loss, as long as the inverter CPU power is not completely lost, the momentary power loss restart will be effective, restart will be according to setting of parameters F02 & F22 and status of External run switch.

Caution:

After any power loss if the Run mode is set to External by parameter F02=1 and if Direct start on power up is also selected by parameter F22=0, please note that the inverter will run on resumption of power.

To ensure safety of operators and to avoid any damages to the machinery, all necessary safety measure must be considered, including disconnection of power to the inverter.

F20	Auto Restart Delay Time
Range	【0.0~6000.0】 Sec
F21	Number of Auto Restart Attempts
Range	【0~10】

- F21=0: The inverter will not auto restart after trips due to fault.
- F21>0, F20=0, after a trip due to fault the inverter will run with the same frequency before power loss, and restarts after an internal delay of 0.5 seconds.
- F21>0, F20>0, after a fault trip the inverter will run with the same frequency before power loss, and restart with a delay according the preset in parameter F20.
- The following faults can be auto restart: PDER, LV-C, OV-C, OC-S, OC-A, OC-d, OC-C and PF.
- **Note:**
Auto restart after a fault will not function while DC injection braking or decelerating to stop

F22	Direct Running on Power Up
Range	【0】 :Enable Direct running after power up 【1】 :Disable Direct running after power up

- When direct run on power up is selected by F22=0 and the inverter is set to external run by (F02=1), if the run switch is ON as power is applied, the inverter will auto start. It is recommend that the power is turned off and the run switch is also off to avoid possibility of injury to operators and damage to machines as the power is reapplied.

Note: If this mode is required all safety measures must be considered including warning labels.

- When direct run on power up is disabled by F22=1 and if the inverter is set to external run by (F02=1), if the run switch is ON as power is applied, the inverter will not auto start and the display will flash with STP1. It will be necessary to turn OFF the run switch and then ON again to start normally.

F23	DC Injection Brake Start Frequency (Hz)
Range	【0.10 ~ 10.00】 Hz

- When DC Injection braking is active DC voltage is applied to the motor, increasing the braking current and resulting in an increase in the strength of the magnetic field trying to lock the motor shaft.
- To enable DC injection braking during a stop operation set the DC injection braking current

(F24) and the DC injection braking time at stop (F25) to a value greater than 0.

Notes:

- Increasing the DC braking time (F25) can reduce the motor stop time
- Increasing the DC braking current (F24) can reduce the motor stop time.
- During stop operation: If the DC braking start frequency < minimum output frequency (01-08), DC braking is activated when the output frequency reaches the minimum output frequency level.

F24	DC Injection Brake Level (%)
Range	【0~ 20】 %. based on the 20% of maximum output voltage

- In V/F mode, the value is equal to 0~20% of max output voltage(01-01)

F25	DC Injection Brake Time (Sec)
Range	【0.0 ~ 25.5】 Sec

- F25/ F23 set the DC injection brake duration and the brake start frequency as shown below.

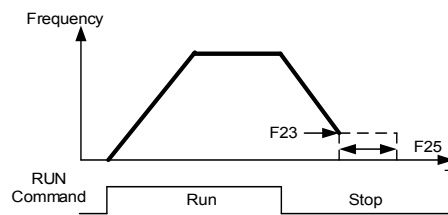

F26	Stopping Method
Range	【0】 :Deceleration to stop. 【1】 :Coast to stop.

- F26 = 【0】 : after receiving stop command, the motor will decelerate to stop according to setting of 00-15, deceleration time 1.
- F26 = 【1】 : after receiving stop command, the motor will free-run (Coast) to stop.

F27	Electronic Motor Overload Protection Operation Mode (OL1)
Range	xxxx0: Disable Electronic Motor Overload Protection xxxx1: Enable Electronic Motor Overload Protection xxx0x: Motor Overload Cold Start xxx1x: Motor Overload Hot Start xx0xx: Standard Motor xx1xx: Invertor Duty Motor (Force Vent)

Electronic Motor Overload Protection OL1 (F27)

- When more than one motor is connected to the inverter set the Overload protection level parameter F11 to the total current of all motors and provide external overload relay protection for each motor.
- When using normal power supply switch, motor overload protection F27=xxx1x (hot start protection curve). Because whenever power is turned off, value of heat will return to default setting.
- F27 = xx0xx. (Standard motor Overload protection). For standard motors with integrated cooling fan when running at low speeds the heat dissipation is not very effective, consider Force vent

cooling then set parameter 08-05=xx1xx for the correct overload protection.

- F27 = xxxx1: Enable electronic overload protection for motor according to Setting in parameter F11 (motor rated current).
- Please refer to the curve in parameter 08-19, as an example for overload protection for a standard motor. (F27=xx0xx)

F28	Prevention of Reverse operation
Range	[0] :Reverse command is valid [1] :Reverse command is invalid

- When F28=1, inverter did not accept reverse operation command.

F29	Carrier Frequency
Range	[1~16] KHz

- Setting range from 1 to 16 represents KHz.
- A low carrier frequency decreases RFI, EMI interference and motor leakage current.
- A low carrier frequency increases motor noise, but reduces motor losses and temperature.
- If cable length between the inverter and the motor is too long, the high-frequency leakage current will cause an increase in inverter output current, which might affect peripheral devices.

F30	Software Version
Range	----
F31	Fault Log Display (Latest 3 faults)
Range	----

- Last three faults are stored in a stack and whenever there is a new fault the previous faults are pushed down the stack. So the fault stored in 2.xxx will be transferred to 3.xxx, and the one in 1.xxx to 2.xxx. The recent fault will be stored in the empty register 1.xxx.
- Use ▲ and ▼ keys to scroll between the fault registers.
- Pressing reset key when parameter 13-02 is displayed then all three fault registers will be cleared and the display for each register will change to 1. ---, 2. ---, 3. ---.
- E.g. fault log content is '1.OC-C'; this indicates the latest fault is OC-C, etc.

13- 08	Reset Drive to Factory Settings
Range	[1150] : Initialization (50Hz,220V/380V system) [1160] : Initialization (60Hz,220V/380V system) [1250] : Initialization (50Hz,230V/400V system) [1260] : Initialization (60Hz,230V/460V system) [1350] : Initialization (50Hz,220V/415V system) [1360] : Initialization (60Hz,230V/400V system)

- When a Parameter lock key number has been entered in parameter 13-07. This key number must be entered first before parameter 13-08 can be used.
- Reset 13-08 to default setting will reset parameter 02 group.
- For built-in EMC filter models, the default setting of 13-08 is "1250".
For without built-in EMC filter models, the default setting of 13-08 is "1360"

00- Basic parameter group

00- 00	Control mode
Range	【0】 : V/F mode 【1】 : Reserved

- **V/F mode** can be used for most applications specifically multi-motor or applications where auto tune is not successful or when a customized V/F pattern may be required. Several V/f patterns are available selectable by parameter 01-00. Select the appropriate V/f pattern based on the application load type and the motor base frequency of 50 or 60 Hz. For selections of the V/f patterns. Refer to description of parameter 01-00

00- 01	Motor Direction Control
Range	【0】 : Forward 【1】 : Reverse

- 00 - 01 is valid in key pad mode only.
- ※Note: When Reverse function is disabled by parameter 11- 00=1 setting 00-01 to 1 ." LOC" will be displayed.

00- 02	Main Run Command Source selection
00- 03	Alternative Run Command Source selection
Range	【0】 : Keypad 【1】 : External Run/Stop Control 【2】 : Communication

- Parameter 00- 02/00- 03 sets the inverter operation command source. For switching between 00-02 and 00-03, use any of the external inputs S1 to S4 and set the relevant parameters (03-00~03-03) to [12]. Refer to parameter group3.

00- 04	Operation modes for external terminals
Range	【0】 : Forward/stop-reverse/stop 【1】 : Run/stop-forward/reverse 【2】 : 3-wire control mode run/stop 【3】 : 2-wire self-holding run/stop

- Parameter 00-04 sets the function of the External Run/Stop and it is used in conjunction with parameters.

00-02(Main Run Source) = 1 or 00-03(Alternative Run source) = 1
(When 00-02/00-03=1, the command comes from External Run /Stop)

Parameters 03-00 to 03-03, which are used to set the required function for the digital inputs [S1 to S4] (multi-function inputs).

Note1: Parameters 03-00 to 03-03 are only required for External Run/stop
(Two wire control mode).

Note2: For External Run /Stop control set parameters in the following order:

1. 00-02 or 00-03
2. 00-04
3. 03-00 to 03-03 as required. Not required for three wire control mode.

When 00-04=0

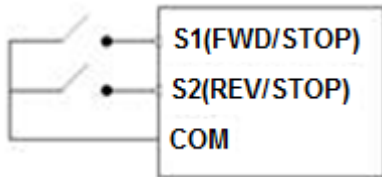

Two external switches are required, one for forward direction and the other for reverse.
Switch type: two position, maintained type. (This is two wire mode).

1. Forward (Run/Stop) Switch

Select one of the multifunction inputs [S1 to S4] and set the relevant parameter 03-00 to 03-03 = 0 (Forward run /Stop mode.)

2. Reverse (Run/Stop) Switch

Select one of the multifunction inputs [S1 to S4] and set the relevant parameter 03-00 to 03-03 = 1 (Reverse run /Stop mode.)

00-04 = 1

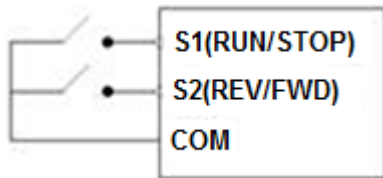

Two external switches are required.

Switch type: two position, maintained type. (This is two wire mode).

1. Run/Stop switch

Select one of the multifunction inputs [S1 to S4] and set the relevant parameter 03-00 to 03-03 = 0 (Run/Stop mode.)

2. Forward/Reverse Switch

Select one of the multifunction inputs [S1 to S4] and set the relevant parameter 03-00 to 03-03 = 1 (Forward/ Reverse direction selection.)

Switch in OFF position = Forward direction

Switch in ON position = Reverse direction

00-04= 2. Three Wire Control mode Run/Stop

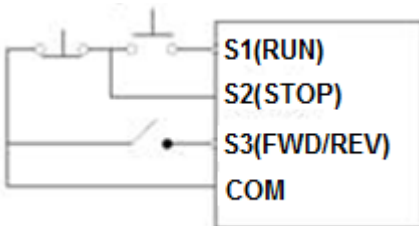

In this mode, two separated momentary push buttons are used for start and stop functions.

In this mode, parameter group 03 for S1 to S4 are not effective.

S1, S2 and S3 are allocated automatically.

Note: For S1 to initiate the Run command. Push button connected to S2 must be connected by a normally closed type contact (NC).

00-04 = 3, Two wire self-holding RUN/STOP

Please see the wiring diagram and timing chart below.

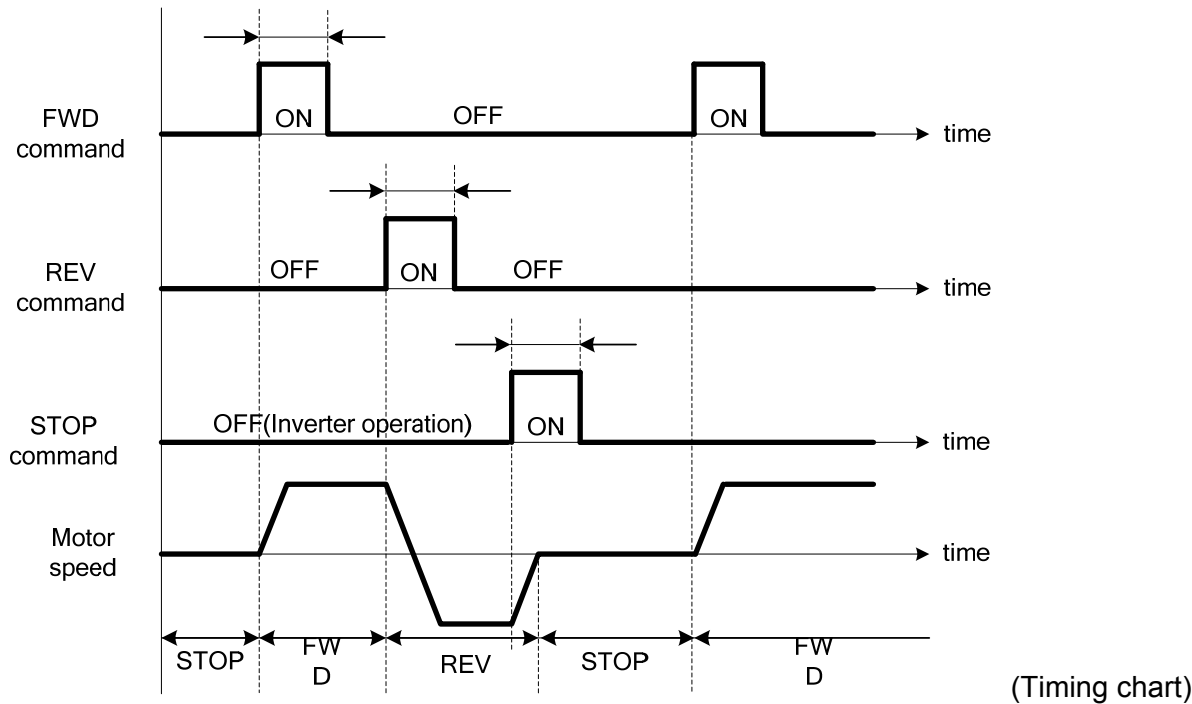
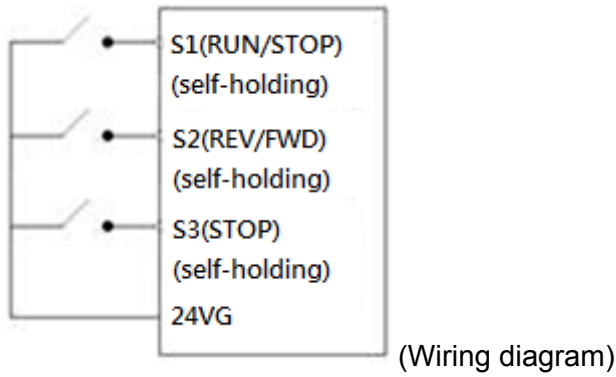

00- 05	Main Frequency Command Source Selection
00- 06	Alternative Frequency Command Source Selection
Range	<p>[0] : UP/DOWN of Keypad [1] : Reserved [2] : External AI Analog Signal Input [3] : Reserved [4] : External Up/Down Frequency Control [5] : Communication setting Frequency [6] : PID Output frequency</p>

➤ Use 00- 05/00- 06 to select the source of the frequency command.

00- 07	Main and Alternative Frequency Command Modes
Range	<p>[0] : Main Or Alternative Frequency. [1] : Main frequency + Alternative Frequency</p>

- When 00- 07= [0] , the frequency source is set by the **Main frequency** parameter 00-05 (Default) or by the **Alternative frequency** parameter 00-06. Use any of the external terminals S1 to S4 and set the relevant parameter 03-00 to 03-03 = [13] to switch from **main** to **Alternative** source.
- When 00- 07 = [1] The Frequency command will be the result of setting of Main & alternative frequencies.

00- 08	Communication Frequency Command
Range	【0.00~599.00】 Hz

- This parameter can be used to read the set frequency in communication mode
- This parameter is only effective in the communication mode.

00- 09	Frequency Command save on power down (Communication mode)
Range	【0】 : Disable 【1】 : Enable

- 00-09= **【0】** Keypad frequency is saved.
- 00-09= **【1】** Frequency set by communication is saved.

00-10	Initial Frequency Selection
Range	【0】 :By Current Frequency Command 【1】 :By Zero Frequency Command 【2】 :By 00-11
00-11	Initial Frequency Set point
Range	【0.00~599.00】 Hz

- This parameter is only effective in keypad mode..
- When 00-10= **【0】** ,the initial frequency will be current frequency.
- When 00-10= **【1】** ,the initial frequency will be 0.
- When 00-10= **【2】** ,the initial frequency will be as set by parameter 00-11.

00-12	Frequency Upper limit
Range	【0.01~599.00】 Hz
00-13	Frequency Lower limit
Range	【0.00~598.99】 Hz

- When 00-13 and the command frequency are both set to 0.00, if RUN is pressed "Stop" is displayed.
- When Frequency command is > than preset in 00-13 inverter output will ramp up from 0.00 to the command frequency.
- When 00-13> 0, and the frequency command value ≤ 00-13, inverter output will ramp up from preset in lower limit to the command frequency.

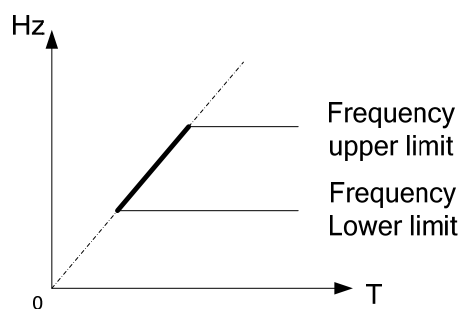

00-14	Acceleration time 1
Range	【0.1~3600.0】 s
00-15	Deceleration time 1
Range	【0.1~3600.0】 s
00-16	Acceleration time 2
Range	【0.1~3600.0】 s
00-17	Deceleration time 2
Range	【0.1~3600.0】 s

- Preset Acceleration and Deceleration times by above parameters are the time taken for the output frequency to ramp up or ramp down between the Upper and the lower V/F frequency limits.
- Actual acceleration and deceleration time is calculated as follows:

$$\text{Actual acceleration time} = \frac{(00-14) \times (\text{set frequency} - \text{the minimum starting frequency})}{\text{V/F Maximum output frequency}}$$

$$\text{Actual deceleration time} = \frac{(00-15) \times (\text{set frequency} - \text{the minimum starting frequency})}{\text{V/F Maximum output frequency}}$$

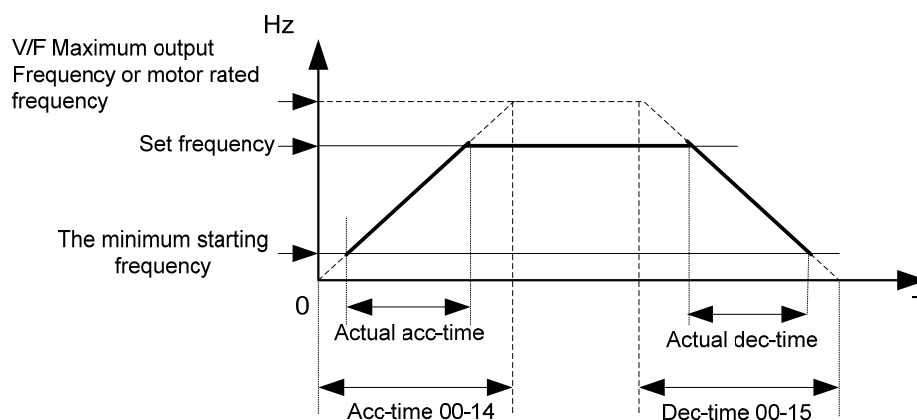

V/F Maximum output frequency is for VF curve, which can be checked from table when VF curve is fixed. Maximum output frequency is 01-02 when VF curve is customized, or motor rated frequency 02-06

00-18	Jog Frequency
Range	[1.00~25.00] Hz
00-19	Jog Acceleration Time
Range	[0.1~25.5] sec
00-20	Jog Deceleration Time
Range	[0.1~25.5] sec

- The JOG function is operational by using the multi-function input terminals S1 to S4 and setting the relevant parameters 03-00~03-03 to [6] JOG FWD or [7] JOG REV. Refer to parameter group 3.

01-V/F command group

01-00	Volts/Hz Patterns (V/F)
Range	[1~7]

- Set 01-00 to one of the following preset V/f selections [1~6] according to the required application.
- Parameters 01-02~01-09 can not be modified (read only).
- Six fixed V/f patterns are shown below. [1~3] for 50 Hz systems and [4~6] for 60 Hz.

TYPE	50Hz		60Hz	
Function	01-00	V/F pattern	01-00	V/F pattern
General Use	[1]		[4]	
High start torque	[2]		[5]	
Decreasing torque	[3]		[6]	

- (V) 100% is the maximum output voltage. B, C point preset % settings will be as table below:-

01-00	B(Xb)	C(Xc)
1/4	7.5%	4.5%
2/5	10%	7%
3/6	25%	7.7%

- Setting 01-00=[7] provides a flexible V/F curve which can be selected by experienced users by setting parameters (01-02~01-09).

01-01	v/f Maximum voltage
Range	200: 【170.0~264.0】 V 400: 【323.0~528.0】 V
01-02	Maximum Frequency (base frequency)
Range	【0.2~ 599.00】 Hz
01-03	Maximum Frequency Voltage Ratio
Range	【0.0 ~ 100.0】 %
01-04	Medium Frequency 2
Range	【0.1~599.00】 Hz
01-05	Medium Frequency Voltage Ratio 2
Range	【0.0 ~ 100.0】 %
01-06	Medium Frequency 1
Range	【0.1~599.00】 Hz
01-07	Medium Frequency Voltage Ratio 1
Range	【0.0 ~ 100.0】 %
01-08	Minimum Frequency
Range	【0.1~599.00】 Hz
01-09	Minimum Frequency Voltage Ratio
Range	【0.0 ~ 100.0】 %

- Max output frequency depends on parameter 01-00, for 01-00=7, it can be set by parameter 01-02.
- For 01-00 ≠7, the maximum output frequency depends on parameter 00-12.

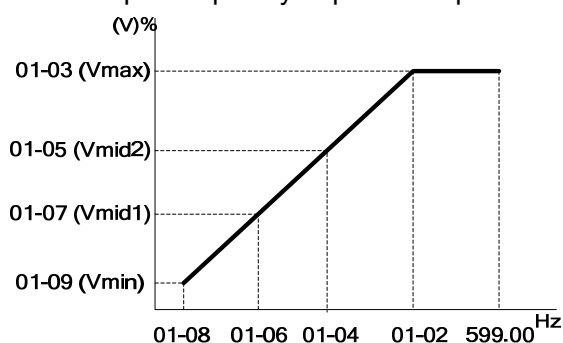

- Please follow the setting rule as below, or the warning message “Err2” will be displayed.
(01-02) ≥ (01-04) ≥ (01-06) ≥ (01-08)

01-10	Volts/Hz Curve Modification (Torque Boost)
Range	【0 ~ 10.0】 %

- Inverter output V / F curve settings for points B, C can be adjusted by parameter 01-10 to improve the output torque.
- Calculation of B, C point voltage: B point voltage = Xb × maximum output voltage, C point voltage = Xc × maximum output voltage (Xb, Xc see the description of 01-00). When 01-10 = 0, the torque improvement is disabled.

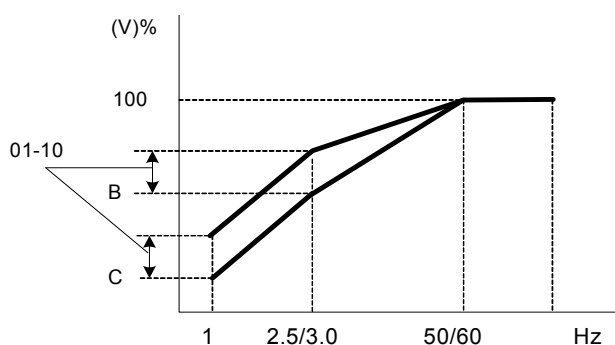

01-11	V/F start Frequency
Range	【0.00 ~10.00】 Hz

- VF Start Frequency is for occasion where Start Frequency higher than zero Hz is needed.

01-12	No-load oscillation suppression gain
Range	【0.0~200.0】 %

- In the situation of no power and no-load that damping is low, active and reactive energy fluctuations will greatly stimulate the inverter output current oscillations. Appropriately adjusting 01-12 can suppress oscillation by **frequency gain**. Compensation is based on the percentage of the load current corresponds to the motor rated current. The adjustment for 01-14 can be increased or decreased every time about 5% to 10%.

01-13	Motor Hunting Prevention Coefficient
Range	【1~8192】
01-14	Motor Hunting Prevention Gain
Range	【0~100】 %
01-15	Motor Hunting Prevention Limit
Range	【0.0~100.0】 %

- In the situation of no power and no-load that damping is low, active and reactive energy fluctuations will greatly stimulate the inverter output current oscillations. Appropriately adjusting 01-12 can suppress oscillation by compensating **V/F voltage command**. Compensation is based on high-pass filtering and the load current value, then it is multiplied by the gain limiting, finally, it is added by the V / F output voltage. The adjustment for 01-14 can be increased or decreased every time about 5% to 10%.
- 01-13 filter coefficients corresponding filter time = 2048 / set point ms, such as 01-13 = 800, then filtering time = 2048/800 = 2.56ms.
- 01-15 of 100% corresponds to 150V (200V series) / 300V (400V series).

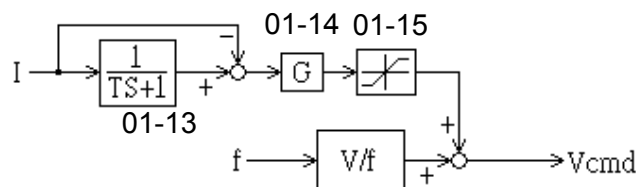

01-16	Auto-Torque Compensation Filter Coefficient
Range	【0.1 ~ 1000.0】 ms
01-17	Auto-torque Compensation Gain
Range	【0 ~ 100】 %
01-18	Auto-torque Compensation Frequency
Range	【1.30 ~ 5.00】 Hz

- Inverter Without Auto-Torque Compensation If 01-17=0. 01-17 compensation is based on V/F maximum output voltage and the load current, The adjustment for 01-17 can be increased or decreased every time about 5% to 10%.

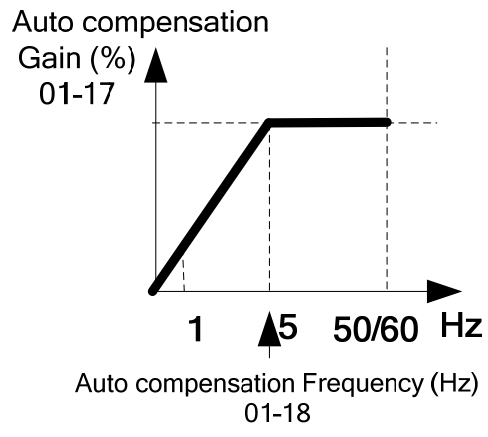

02- Motor parameter group

02- 00	Motor no load current. (For slip compensation calculation)
Range	----
02- 01	Motor Rated Current
Range	----
02- 02	Slip Compensation Gain
Range	【0.0 ~ 200.0】 (%)

- When the load causes the actual motor speed to be reduced below the speed set by inverter output frequency (Slip), parameter 02-02 Slip compensation can be used to correct the speed.

Slip compensation calculation in V/F mode:

$$\text{Slip compensation boost} = \frac{\text{Output Current}-(02-00)}{(02-01)-(02-00)} \times (02-02) \times \text{Rate motor slip}$$

Motor slip = Motor synchronous speed- Motor Rated Speed

$$(02-02)\text{approximate Value} = \frac{\text{Motor synchronization speed}-\text{Rated speed}}{\text{Motor synchronization speed}}$$

Example: 4 poles, 60Hz induction motor synchronization speed = $\frac{120}{4} \times 60 = 1800(\text{RPM})$

- ※Note: Parameters 02- 00 / 02- 01 / 02- 04 / 02- 05 have to be set according to the specific motor data and in relation to the Inverter rating model parameter (13- 00).

02- 03	Motor Rated Speed
Range	----

- Slide compensation limit, inverter will calculate the motor slide according to 02-03. V/F slide compensation will not be higher than 02-03.

Note: Please set the value according to motor's nameplate.

02- 04	Motor Rated Voltage
Range	----

- In order to prevent the output voltage of inverter is too high. The output voltage value will not be higher than 02-04. 02-04 can be changed during operation.

Note: Please set the value according to motor's nameplate.

02- 05	Motor Rated Power
Range	【0.1~ dependent on the different horsepower】 kW
02- 06	Motor Rated Frequency
Range	【0~599.0】 Hz

02- 15	Low Frequency Torque Gain
Range	【0~100】 %

- Inverter of dead zone (IGBT on short) will lower the torque of output in the system, leading to lower motor efficiency. Setting 02-15 can not only reduce this situation but also increase torque of output in low frequency. Default setting is 50, means 50% voltage compensation. 100% of 02-15 according to output voltage that is less affected by dead zone.

03- External digital inputs & Relay Output functions

03- 00	Multifunction Input Term. S1
03- 01	Multifunction Input Term. S2
03- 02	Multifunction Input Term. S3
03- 03	Multifunction Input Term. S4
Range	<p> [0] :Forward/Stop Command------(Parameters 00- 02/00-03=1 & 00-04) [1] :Reverse/Stop Command------(Parameters 00-02/00-03=1 & 00-04) [2] :Preset Speed setting bit 0 (5- 02)------(Parameter Group5) [3] :Preset Speed setting bit 1 (5- 03)------(Parameter Group5) [4] :Preset Speed setting bit 2 (5- 05) ------(Parameter Group5) [6] :JOG Forward Command------(Parameters 00-18~00-20) [7] :JOG Reverse Command------(Parameters 00-18~00-20) [8] :Up Command----- (Parameters 00- 05/00- 06=4& 03-06/03-07) [9] :Down Command----- (Parameters 00- 05/00- 06=4& 03-06/03-07) [10] : Second Acc/Dec time [11] : Disable Acc/Dec [12] : Main/ Alternative run source Select------(Parameters 00- 02/00- 03) [13] : Main/Alternative Frequency Command Select-----(Parameters 00- 05/00- 06) [14] : Rapid Stop (controlled deceleration stop) [15] : Base Block (Coast to stop) [16] : Disable PID Function.------(Parameter Goup10) [17] : Reset [18] : Enable Auto Run Mode------(Parameter Group 6) </p>

2) For setting parameters 03- 00~03- 03 to **[0, 1]** External Run/Stop Control, refer to 00- 04.

A. 2-wire method. Mode 1.

Example: FWD/STOP and REV/STOP from two inputs (S1&S2)

Set 00- 04= **[0]** , S1: 03- 00= **[0]** (FWD/STOP) , S2: 03- 01= **[1]** (REV/STOP);

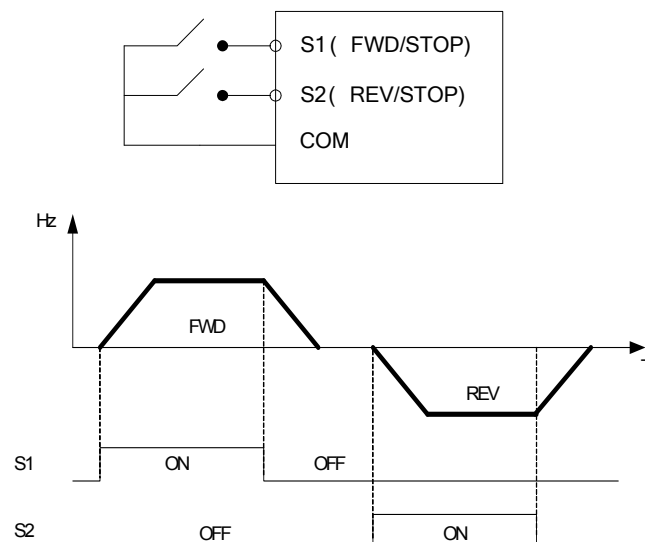

※ **Note:** If both forward and reverse commands are ON, it will be treated as a STOP signal.

B. 2-wire method. Mode 2.

Example: RUN/STOP and REV/FWD from two inputs (S1&S2)

Set 00- 04= [1] ; S1: 03- 00= [0] (RUN/STOP); S2:03- 01= [1] (REV/FWD);

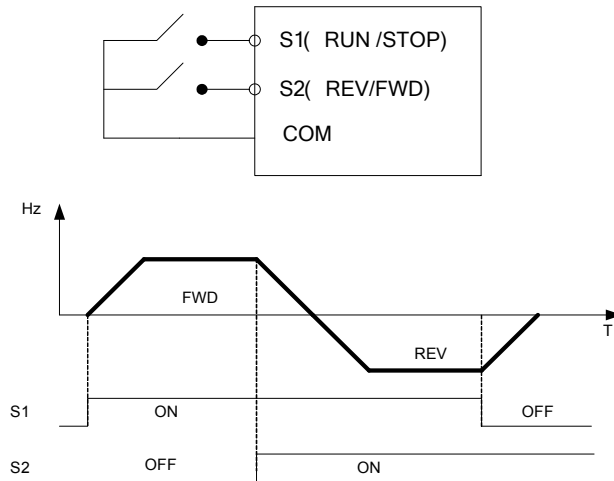

C. 3-wire method.

Example: Two separate push buttons for RUN & STOP and a two position switch for FWD/ REV

Set 00- 04=2 (3 wire control mode), then terminals S1, S2 and S3 are dedicated to this function and preset selections for parameters 03-00, 03-01 and 03-02 are not relevant.

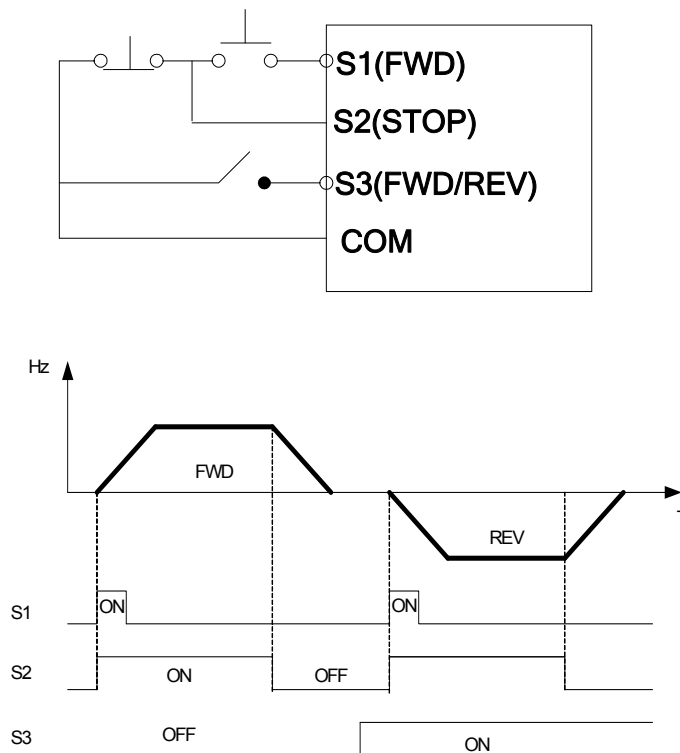

3) Parameters 03- 00~03- 03= [4, 3, 2] Preset speed selections.

Combination of any three terminals from S1~ S4 can be used to select preset speeds 0 to 7 according to the table below, for example timing diagram refer to Group 5 description.

Preset speed	Function setting and state of any three (A,B,C) of terminal S1~S4			Frequency	Acc-time	Dec-time
	terminal A=4	terminal B =3	terminal C =2			
speed 0	OFF	OFF	OFF	05- 01	05- 17	05-18
speed 1	OFF	OFF	ON	05- 02	05- 19	05-20
speed 2	OFF	ON	OFF	05- 03	05- 21	05-22
speed 3	OFF	ON	ON	05- 04	05- 23	05-24
speed 4	ON	OFF	OFF	05- 05	05- 25	05-26
speed 5	ON	OFF	ON	05- 06	05- 27	05-28
speed 6	ON	ON	OFF	05- 07	05- 29	05-30
speed 7	ON	ON	ON	05- 08	05- 31	05-32

4) 03- 00~03- 03= [6, 7] Forward/ Reverse JOG

When an input terminal is set to function [6] and is turned on, inverter will work in jog forward mode.

When an input terminal is set to function [7] and is turned on, inverter will work in jog reverse mode.

Note: If jog forward and jog reverse function is enabled at the same time, inverter will enter stop mode.

5) 03- 00~03- 03= [8, 9] UP/DOWN

When an input terminal is set to function [8] and is turned on, frequency command is increased according to the UP/DOWN, increment/decrement step set in parameter 03-06.

If the input is kept on continuously, the frequency command increases accordingly until the upper frequency limit is reached.

When an input terminal is set to function [9] and is turned on, frequency command decreases according to the UP/DOWN increment/decrement step set in parameter 03-06.

If the input is kept on continuously, the frequency command decreases accordingly and in relation to settings for parameter 03-06 and 3-07 until Zero speed is reached.

Refer to group 3 parameter description.

6) 03- 00~03- 03= [10] Second Acc/Dec time

When an input terminal is set to function [10] and is turned on, the actual acceleration and deceleration time will be according to the time for 2nd Accel/Decel set in parameters 00-16 and 00-17.

if the input is turned off, the acceleration and deceleration times will be according to the default accel/dec 1 set in parameters 00-14 & 00-15.

7) 03- 00~03- 03= [11] Disable Acc/Dec function

When an input terminal is set to function [11] and is turned on, acceleration and deceleration function will be disabled and the frequency at the time is maintained. (constant speed mode)

If the input is turned off, acceleration and deceleration function is enabled again.

For an example see the following diagram.

Accel/Decel & Enable/Disable timing diagram using terminal S1 and parameter 03-00 = 11.

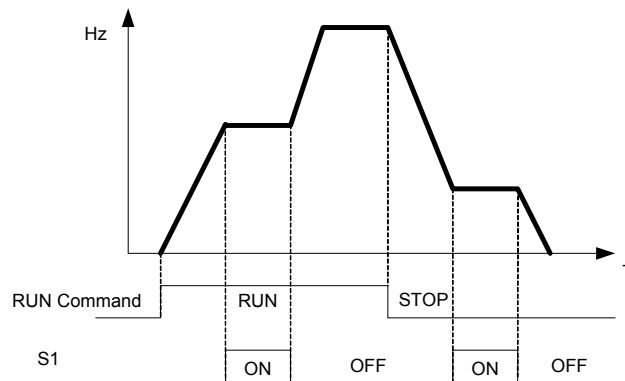

8) 03- 00~03- 03= [12] Main/ Alternative run source select.

When an input terminal is set to function [12] and is turned on, the run command source is according to parameter 00-03(Alternative Run source).If the Input is off it will be according to 00-02 (Main run source).

9) 03- 00~03- 03= [13] Main/ Alternative Frequency source Select

When an input terminal is set to function [13] and is turned on, the frequency source is according to parameter 00-06(Alternative Frequency source).If the Input is off it will be according to 00-05 (Main Frequency source).

10) 03- 00~03- 03= [14] Rapid Stop (controlled deceleration stop)

When DI is on, keypad shows “E.S”, motor decelerates to stop according to the setting value of 00-17. When turning off DI (remove ES), the inverter stays in “stop” status. The inverter runs again after giving Run command.

11) 03- 00~03- 03= [15] Base Block (Coast to stop)

When DI is on, keypad shows “b.b”, motor free runs to stop. When turning off DI (remove b.b), the inverter starts running from 5Hz below the set frequency to 5Hz above the set frequency, then running to the setting frequency.

12) 03- 00~03- 03= [16] Disable PID Function.

When an input terminal is set to function [16] and is turned on, PID functions is disabled, if it is turned off , PID function is enabled again.

13) 03- 00~03- 03= [17] Reset

When a failure that can be manually reset occurs, turn on a terminal with function [17] , the failure will be reset. (Same function as the Reset button on keypad).

14) 03- 00~03- 03= [18] Auto _ Run Mode

When an input terminal is set to function [18] , the programmable auto- sequencer function is enabled, Refer to description of parameter group 6.

03-06	Up/Down frequency step
Range	[0.00~5.00] Hz

Example: S1: 03-00= [8] Up frequency command, S2: 03-01= [9] Down frequency command, 03-06= [Δ] Hz

Mode1: If UP or DOWN input terminals are turned on for less than 2 seconds, for every On operation frequency changes by Δ Hz.

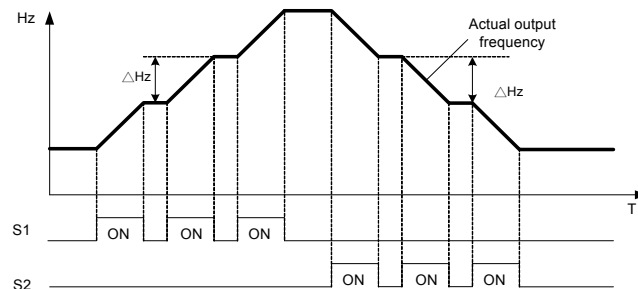

Mode 2: If UP or DOWN input terminals are turned on for more than 2 seconds, the original UP/DOWN mode is restored. Output frequency Ramps up or down as long as the input is kept ON. As shown in the diagram below.

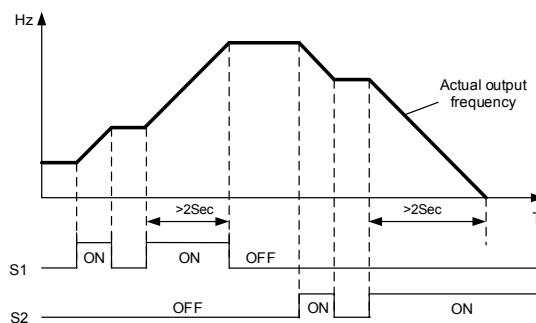

03-07	Up/Down keep Frequency status after a stop command
Range	<p>After a stop command in Up/Down mode:</p> <p>[0] : The preset frequency is held as the inverter stops.</p> <p>[1] : The preset frequency is reset to 0 Hz as the inverter stops.</p> <p>[2] : The preset frequency is held as the inverter stops, the function remains enabled.</p>

- 03-07=0, when run signal is removed (Stop Command), the output frequency is stored in parameter 05-01. In stop mode since frequency can not be increased or decreased from Up/Down terminals then keypad can be used to change the frequency by modifying parameter 05-01.
- 03-07=1, in Up/down frequency mode inverter will ramp up from 0Hz on Run command and Ramp down to 0 Hz on stop command.
- 03-07=2, when inverter stopped, Up/down key is still valid.

03-08	Multifunction terminals S1~S5 scan time
Range	[1~200] 2ms

- Multifunction input terminal On/Off periods will be scanned for the number of cycles according to the set value in parameter 03-08. If the signal status for on or off period is less than the set period it will be treated as noise.
- Scan period unit is 1ms.
- Use this parameter if unstable input signal is expected, however setting long scan time periods results in slower response times.

03-09	s1~s5 Input type selection NO & NC	
Range	[xxxx0] :S1 NO	[xxxx1] :S1 NC
	[xxx0x] :S2 NO	[xxx1x] :S2 NC
	[xx0xx] :S3 NO	[xx1xx] :S3 NC
	[x0xxx] :S4 NO	[x1xxx] :S4 NC

- (NO) Normally open, (NC) Normally closed. Select as required.
- For selecting Normally Open (NO) or Normally Closed (NC) set the relevant digit in parameter 03-09 to 0 or 1 as required.
- Set Parameter 03-09 first before you use the Parameters 00-02/00-03=1 to set the inverter run mode to External multifunction inputs.

Note: Before the setting terminal is connected to the normally open/normally closed switch, do not set the running command to come from the external terminal, otherwise it will cause unnecessary damage.

03-11	Multifunction Output Relay RY1 functions. (Terminals RA, RB)
Range	[0] :Run [1] :Fault [2] :Setting Frequency Reached -----(refer to 03-14) [3] :Frequency Reached (3-13±3-14) -----(refer to 03-13/03-14) [4] :Output Frequency Detection 1 (> 03-13) -----(refer to 03-13) [5] :Output Frequency Detection 2 (< 03-13) -----(refer to 03-13) [6] :Auto-Restart [7] :Momentary AC Power Loss ----- (refer to 07-00) [8] :Rapid Stop (Decelerate to Stop) [9] :Base Block [10] :Motor Overload Protection (OL1) [11] :Drive Overload Protection (OL2) [13] :Output Current Reached ----- (refer to 03-15/03-16) [14] :Brake Control ----- (refer to 03-17/03-18) [15] :PID Feedback Disconnection Detection ----- (refer to 10-11/10-13)
03-13	Frequency Detection Level
Range	[0.00~599.00] Hz
03-14	Frequency Detection Width
Range	[0.00~30.00] Hz

Output relay RY1, function descriptions:

- 1) 03-11 = [0] . RY1 will be ON with run signal.
- 2) 03-11 = [1] . RY1 will be ON with inverter faults.
- 3) 03-11 = [2] . RY1 will be ON when output frequency reached setting frequency.

When Output Freq. = Setting Frequency - Frequency Detection Width (03-14),
Relay Output will be ON.

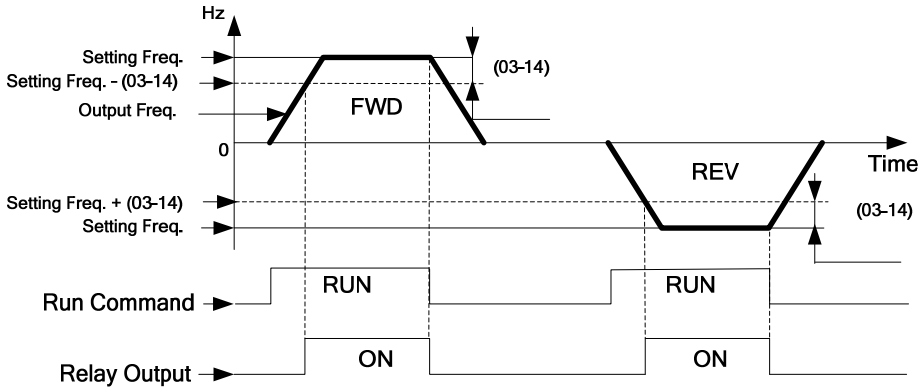

Example :

Setting Freq. =30, and Frequency Detection Width (03-14) =5, relay will be ON when output frequency reached 25Hz to 30Hz and Run Command is on (Allowable tolerance ± 0.01).

- 4) **03-11= [3]** RY1 will be ON when Setting Freq. and Output Frequency reached (03-13 +/- 03-14).

When Frequency Detection Range Lower Limit < Setting Freq. < Frequency Detection Range Upper Limit
And, Frequency Detection Range Lower Limit < Output Freq. < Frequency Detection Range Upper Limit
Relay output will be ON! Allowable tolerance ± 0.01 !

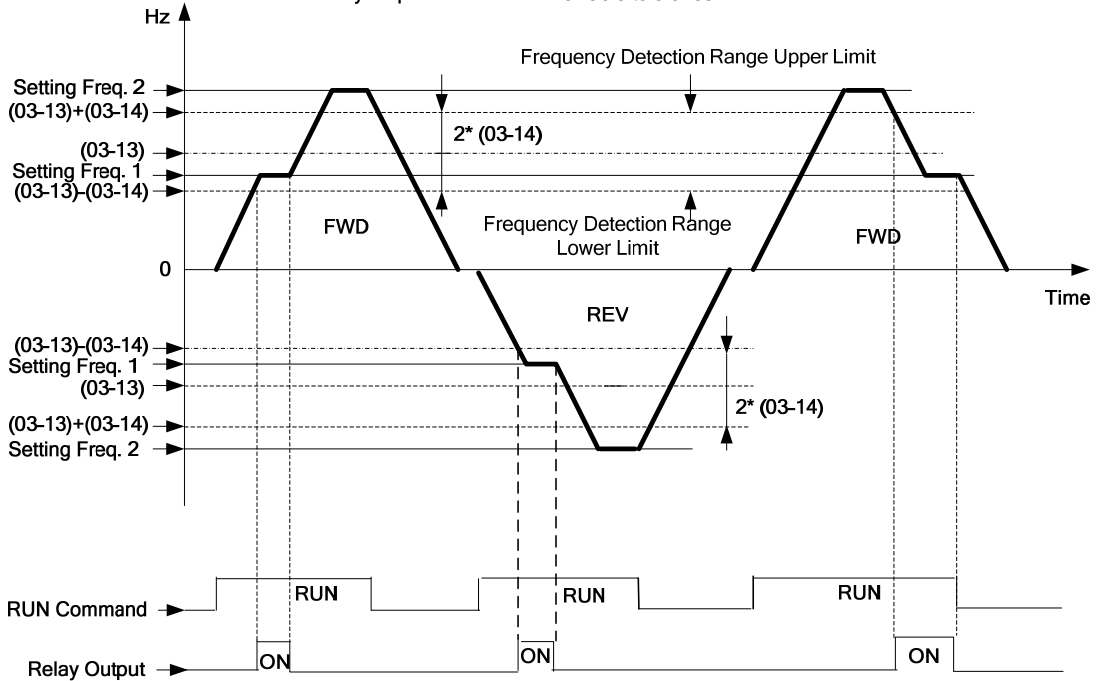

Example:

Frequency Detection Level (03-13) =30, and Frequency Detection Width (03-14) =5 cause frequency detection range upper limit = 35, and Frequency Detection Range lower limit = 25. So RY1 will be on when Setting Freq. and Output Freq. are both under these limits; on the other hand, RY1 will be off when Setting Freq. and Output Freq. are not under these limits either.

- 5) **03-11= [4]** , RY1 will be on while Output Freq. > Frequency Detection Level (03-13).

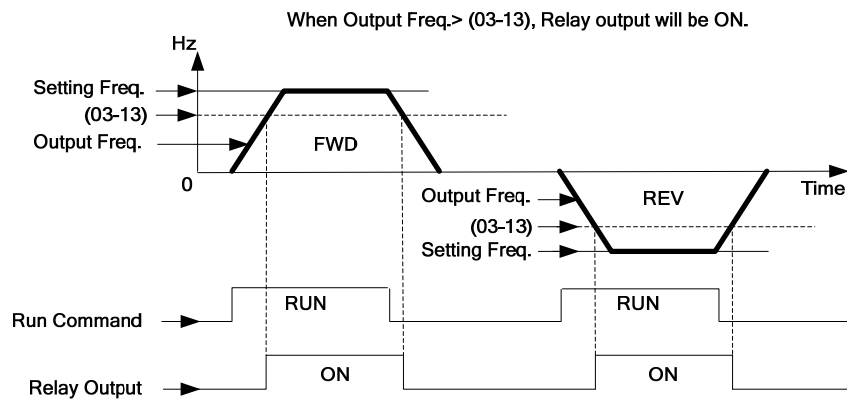

6) **03-11= [5]** . RY1 will be on while Output Freq. < Frequency Detection Level (03-13).

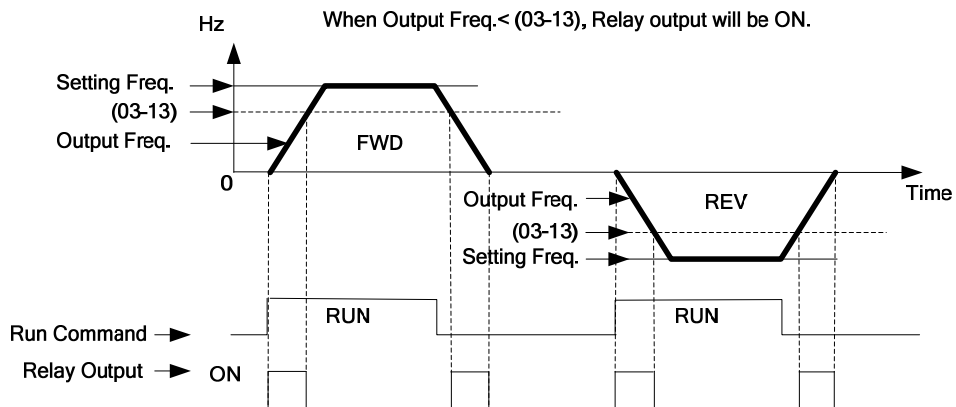

03-15	Output Current Detection Level
Range	[0.1~999.9] A
03-16	Output Current Detection Period
Range	[0.1~10.0] Sec

- 03-11= [13] , RY1 will be on as soon as the output current value > Output current detection level (03-15).
- 03-15: Setting range (0.1~15.0 Amps) as required according to the rated motor current.
- 03-16: Setting range (0.1~10.0) unit: seconds.

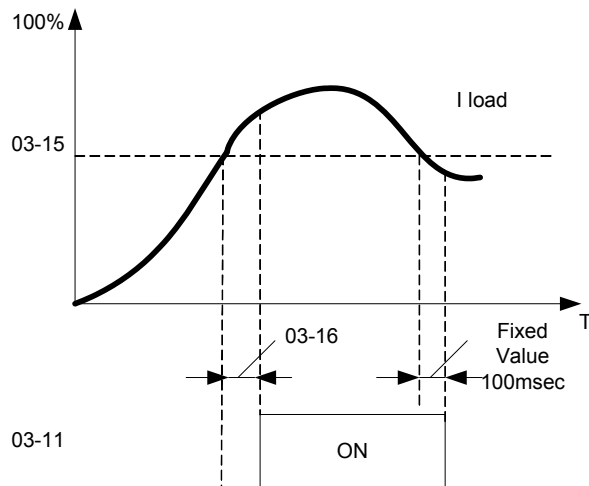

03-17	Braking Release Level
Range	[0.00~20.00] Hz
03-18	Braking Engage Level
Range	[0.00~20.00] Hz

➤ If 03-11 = [14]

- (a) In accelerating mode, RY1 will be ON as soon as the actual output frequency reaches the external Braking release level set in parameter 03-17.
- (b) In decelerating mode, RY1 will be OFF as soon as the actual output frequency reaches the external Braking engage level set in parameter 03-18.

Timing diagram for 03-17 < 03-18 is shown below:

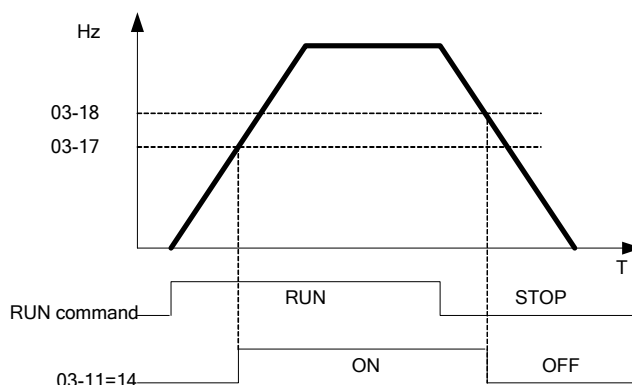

Timing diagram for 03-17 > 03-18 is shown below:

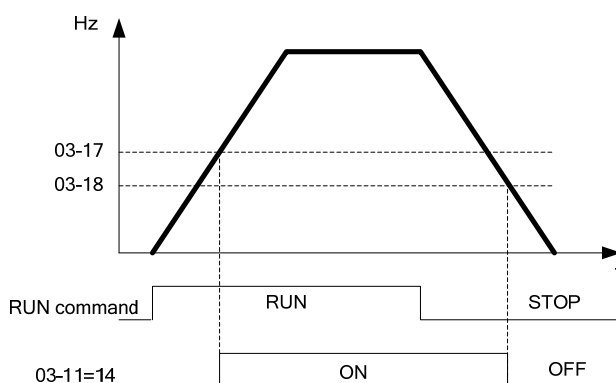

03-19	Relay Output Status type
Range	[0] : A (Normally open) [1] : B (Normally close)
03-20	Braking Transistor ON Level
Range	200V: [240.0~400.0] VDC 400V: [500.0~800.0] VDC
03-21	Braking Transistor OFF Level
Range	200V: [240.0~400.0] VDC 400V: [500.0~800.0] VDC

- When DC bus voltage > 03-20, excess voltage will be applied to the external braking resistor.
- When DC bus voltage ≤ 03-21, braking transistor will be switched off.
- Do not set 03-21 > 03-20, or display will show Err2, which means parameter setting error.

04- External analog signal input / output functions

04- 00	Analog Voltage & Current input selections
Range	AVI/ACI [0] : 0~10V/0~20mA [1] : Reserved [2] : Reserved [3] : 2~10V/4~20mA

➤ **Analog Input Scaling formulas:-**

AVI(0~10V), ACI(0~20mA)

$$AVI(0\sim 10V):F(Hz) = \frac{V(v)}{10(v)} \times X(00-12)$$

$$ACI(0\sim 20mA):F(Hz) = \frac{I(mA)}{20(mA)} \times X(00-12)$$

AVI(2~10V), ACI(4~20mA)

$$AVI(2\sim 10V):F(Hz) = \frac{V-2(v)}{10-2(v)} \times X(00-12)$$

$$ACI(4\sim 20mA):F(Hz) = \frac{I-4(mA)}{20-4(mA)} \times X(00-12)$$

04- 01	AVI/ACI signal verification Scan Time
Range	[1~200] 2ms
04- 02	AVI/ACI Gain
Range	[0 ~ 1000] %
04- 03	AVI/ACI Bias
Range	[0~ 100] %
04- 04	AVI/ACI Bias Selection
Range	[0] : Positive [1] : Negative
04- 05	AVI/ACI Slope
Range	[0] : Positive [1] : Negative

➤ Set 04- 01 for Analog signal verification.

Inverter reads the average values of A/D signal once per (04- 01/04- 06 x 2ms). Set scan intervals according to the application and with consideration for signal instability or interference effects on the signal by external sources. Long scan times will result in slower response time.

- AVI example (analog voltage input) by adjusting Gain, Bias & Slope parameters (04-02~04-05).
- (1) Positive Bias type (04-04= 0) and effects of modifying Bias amount by parameter 04-03 and Slope type with parameter 04-05 are shown in Fig 1&2.

Figure 1.

	04- 02	04- 03	04- 04	04- 05
A	100%	50%	0	0
B	100%	0%	0	0

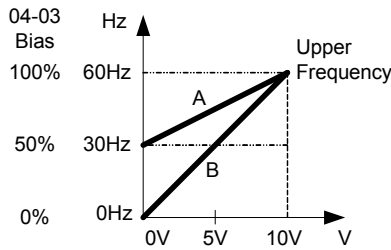
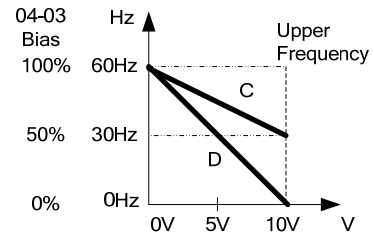

Figure 2.

	04- 02	04- 03	04- 04	04- 05
C	100%	50%	0	1
D	100%	0%	0	1



Negative Bias type and effects of modifying Bias amount by parameter 04-03 and Slope type with parameter 04-05 are shown in Fig 3&4.

Figure3:

	04- 02	04- 03	04- 04	04- 05
E	100%	20%	1	0

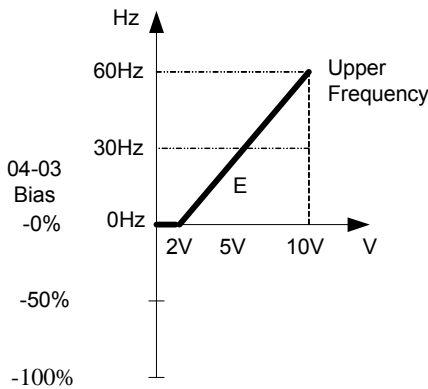
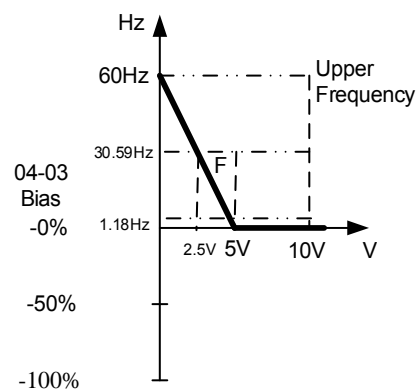

Figure4:

	04- 02	04- 03	04- 04	04- 05
F	100%	50%	1	1



- (2) Offset bias set to 0% (04-03) and effect of modifying Analog Gain (04-02), Bias type (04-04) and slope type(04-05) are shown in shown Fig 5&6.

Figure 5

	04- 02	04- 03	04- 04	04- 05
A'	50%	0%	0/1	0
B'	200%	0%	0/1	0

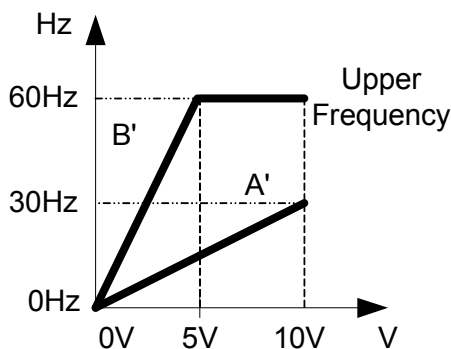
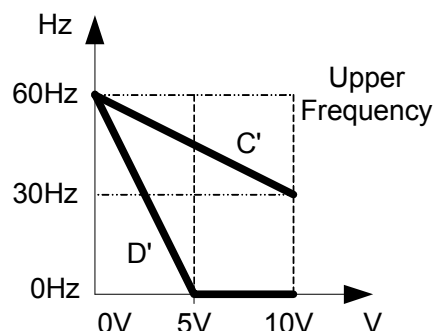

Figure 6

	04- 02	04- 03	04- 04	04- 05
C'	50%	0%	0/1	1
D'	200%	0%	0/1	1



(3) Various other examples of analog input scaling and modification are shown in following figures 7, 8, 9 & 10.

Figure 7

	04- 02	04- 03	04- 04	04- 05
a	50%	50%	0	0
b	200%	50%	0	0

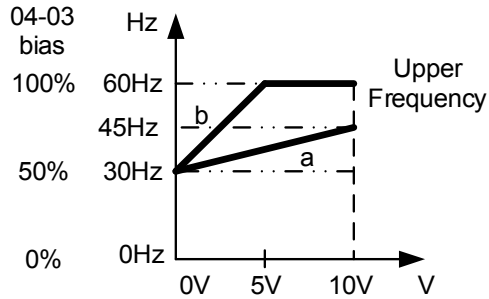

Figure 8

	04- 02	04- 03	04- 04	04- 05
c	50%	50%	0	1
d	200%	50%	0	1

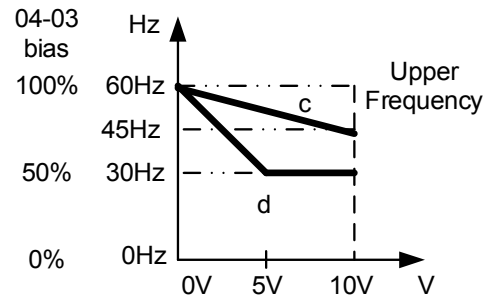

Figure 9

	04- 02	04- 03	04- 04	04- 05
e	50%	20%	1	0
f	200%	20%	1	0

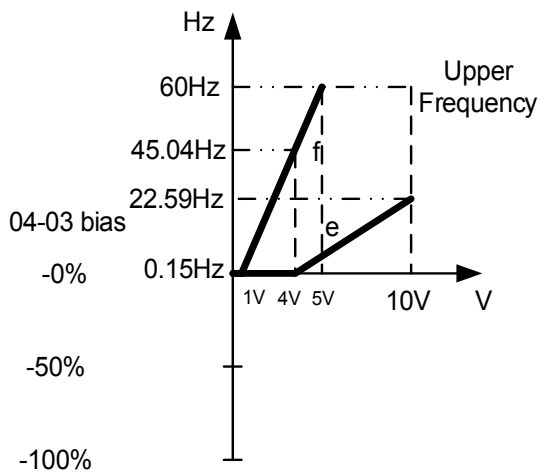
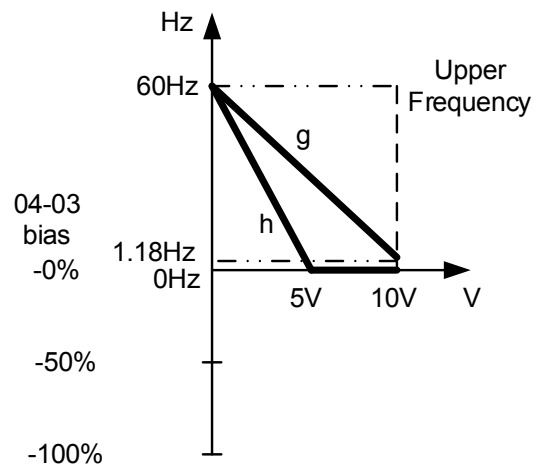

Figure 10

	04- 02	04- 03	04- 04	04- 05
g	50%	50%	1	1
h	200%	0%	0	1



04-11	Analog Output (AO) function selection.
Range	[0] :Output frequency [1] :Frequency Setting [2] :Output voltage [3] :DC Bus Voltage [4] :Output current

Example: Set 04-11 required according to the following table.

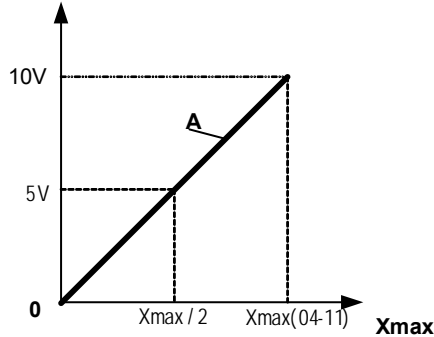

04-11	A	Xmax
[0]	Output frequency	upper frequency limit
[1]	Frequency Setting	upper frequency limit
[2]	Output voltage	Motor Rated Voltage
[3]	DC Bus Voltage	220V: 0~500V 380V: 0~1000V
[4]	Output current	2 times rated current of inverter

04-12	AO Gain
Range	[0 ~ 1000] %
04-13	AO Bias
Range	[0 ~ 100] %
04-14	AO Bias Selection
Range	[0] : Positive [1] : Negative
04-15	AO Slope
Range	[0] : Positive [1] : Negative

- Select the Analog output type for the multifunction analog output on terminal as required by parameter 04-11. Output format is 0-10Vdc. The output voltage level can be scaled and modified by parameters 04-12 to 04-15 if necessary.
- The modification format will be same as the examples shown previously for Analog Voltage Input (AVI) parameters 4-02 to 4-05.

Note: the max output voltage is 10V due to the hardware of the circuit.

Use external devices that require a maximum of 10V dc signal.

05- Preset Frequency Selections.

05- 00	Preset Speed Control mode Selection
Range	[0] :Common Acceleration / Deceleration. [1] : Individual Acceleration / Deceleration for each preset speed 0-7.

05- 01	Preset Speed 0 (Keypad Frequency)
05- 02	Preset Speed 1
05- 03	Preset Speed 2
05- 04	Preset Speed 3
05- 05	Preset Speed 4
05- 06	Preset Speed 5
05- 07	Preset Speed 6
05- 08	Preset Speed 7
Range	[0.00 ~ 599.00] Hz
05-17	Preset Speed 0 Acceleration time
05-18	Preset Speed 0 Deceleration time
05-19	Preset Speed 1 Acceleration time
05- 20	Preset Speed 1 Deceleration time
05- 21	Preset Speed 2 Acceleration time
05- 22	Preset Speed 2 Deceleration time
05- 23	Preset Speed 3 Acceleration time
05- 24	Preset Speed 3 Deceleration time
05- 25	Preset Speed 4 Acceleration time
05- 26	Preset Speed 4 Deceleration time
05- 27	Preset Speed 5 Acceleration time
05- 28	Preset Speed 5 Deceleration time
05- 29	Preset Speed 6 Acceleration time
05- 30	Preset Speed 6 Deceleration time
05- 31	Preset Speed 7 Acceleration time
05- 32	Preset Speed 7 Deceleration time
Range	[0.1 ~ 3600.0] s

- When 05- 00 = [0] Acceleration /Deceleration 1 or 2 set by parameters 00-14/00-15 or 00-16/00-17 apply to all speeds.
- When 05- 00 = [1] Individual Acceleration /Deceleration apply to each preset speed 0-7. Parameters 05-17 to 05-32.
- Formula for calculating acceleration and deceleration time:

V/F mode:

$$\text{Actual Acc time} = \frac{\text{Time of Accel1 or 2 x Preset Frequency}}{\text{V/F Max Frequency}}$$

$$\text{Actual Dec time} = \frac{\text{Time of Accel1 or 2 x Preset Frequency}}{\text{V/F Max Frequency}}$$

- V/F Maximum output frequency=parameter 01-02 when programmable V/F is selected by 01-00= [7] , Motor rated output frequency is set by parameter 02-06.
- V/F Maximum output frequency = 50.00 hz or 60.00 hz when preset V/F patterns are selected. 01-00≠ [7] .

Following examples is in V/F mode:

Example 1 01-00≠7, 01-02=50Hz, 05-02=10Hz (preset speed1),
05-19=5s (Accel time), 05-20=20s (Decel time)

$$\text{Preset speed 1 Actual Accel time} = \frac{(05-19) \times 10(\text{Hz})}{01-02} = 1(\text{s})$$

$$\text{Preset speed 1 Actual Decel time} = \frac{(05-20) \times 10(\text{Hz})}{01-02} = 4(\text{s})$$

- **Multi speed run/stop cycles with Individual acceleration/deceleration time. 05-00= [1]**
- Two modes are shown below:-
- Mode1 = On/Off run command
- Mode2= Continuous run command

Mode1 Example: 00-02= [1] (External Run/Stop Control).
00-04= [1] (Operation Mode : Run/stop-forward/reverse).
S1: 03-00= [0] (RUN/STOP);
S2: 03-01= [1] (Forward/Reverse);
S3: 03-02= [2] (Preset speed 1);
S4: 03-03= [3] (Preset speed 2);

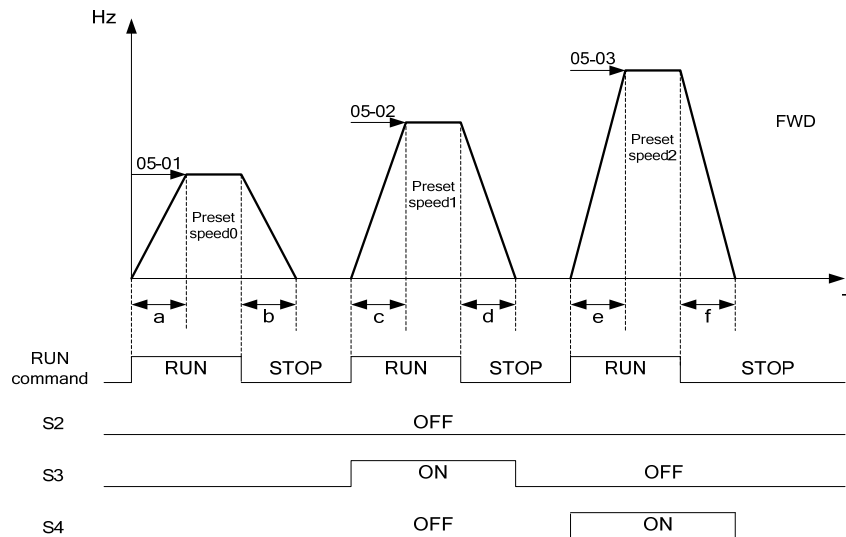

When the run command is On/Off, acceleration and deceleration times for each cycle can be calculated as below:- time unit is in seconds'

$$a = \frac{(05-17) \times (05-01)}{01-02}, \quad b = \frac{(05-18) \times (05-01)}{01-02}, \quad c = \frac{(05-19) \times (05-02)}{01-02}, \quad d = \frac{(05-20) \times (05-02)}{01-02} \dots$$

Mode2 Example. Continuous run command.

- Set S1 for Continuous Run
- Set 00-01= 0 or 1 For Forward /Reverse direction selection
- Set multi function terminals S2, S3 & S4 for setting three different preset speeds

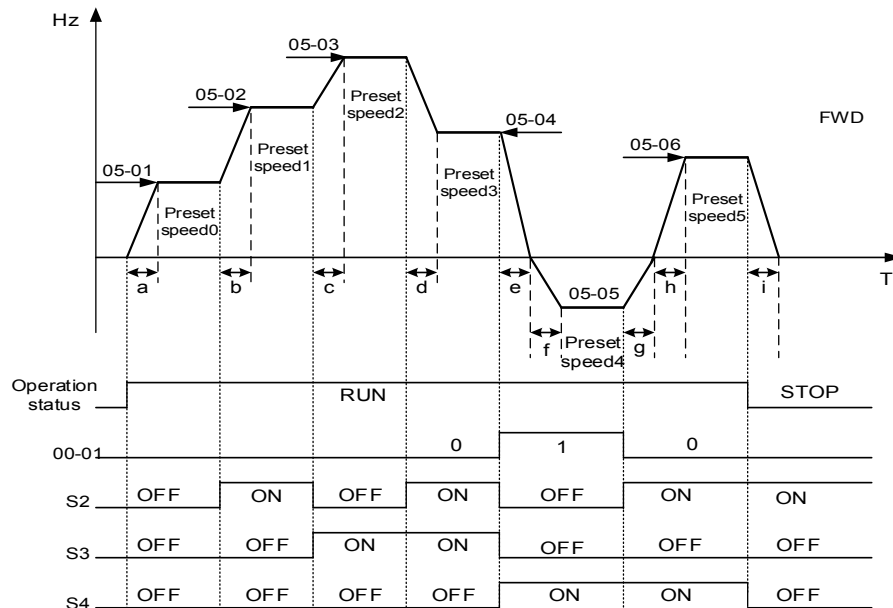

When the run command is continuous, acceleration and deceleration times for each segment can be calculated as below:-

$$\text{Ex] } a = \frac{(05-17) \times (05-01)}{01-02}, b = \frac{(05-19) \times [(05-02) - (05-01)]}{01-02}$$

$$c = \frac{(05-21) \times [(05-03) - (05-02)]}{01-02}, d = \frac{(05-24) \times [(05-03) - (05-04)]}{01-02}$$

$$e = \frac{(05-26) \times (05-04)}{01-02}, f = \frac{(05-25) \times (05-05)}{01-02}, g = \frac{(05-27) \times (05-05)}{01-02}$$

$$h = \frac{(05-27) \times (05-06)}{01-02}, i = \frac{(05-19) \times (05-06)}{01-02} \dots \dots \text{Unit(sec)}$$

06- Auto Run(Auto Sequencer) function

06- 00	Auto Run(sequencer) mode selection
Range	<p>[0] : Disabled</p> <p>[1] : Single cycle, continues to run from the unfinished step if restarted.</p> <p>[2] : Periodic cycle, continues to run from the unfinished step if restarted.</p> <p>[3] : Single cycle, then holds the speed of final step to run. Continues to run from the unfinished step if restarted.</p> <p>[4] : Single cycle, starts a new cycle if restarted.</p> <p>[5] : Periodic cycle, starts a new cycle if restarted.</p> <p>[6] : Single cycle, then hold the speed of final step to run, starts a new cycle if restarted.</p>

Frequency of the step 0 is set by parameter 05-01 keypad Frequency.	
06- 01	Auto Run Mode Frequency Command 1
06- 02	Auto Run Mode Frequency Command 2
06- 03	Auto Run Mode Frequency Command 3
06- 04	Auto Run Mode Frequency Command 4
06- 05	Auto Run Mode Frequency Command 5
06- 06	Auto Run Mode Frequency Command 6
06- 07	Auto Run Mode Frequency Command 7
Range	【0.00 ~ 599.00】 Hz

06- 16	Auto Run Mode Running Time Setting0
06- 17	Auto Run Mode Running Time Setting1
06- 18	Auto Run Mode Running Time Setting2
06- 19	Auto Run Mode Running Time Setting3
06- 20	Auto Run Mode Running Time Setting4
06- 21	Auto Run Mode Running Time Setting5
06- 22	Auto Run Mode Running Time Setting6
06- 23	Auto Run Mode Running Time Setting7
Range	【0.00 ~ 3600.0】 Sec

06- 32	Auto Run Mode Running Direction0
06- 33	Auto Run Mode Running Direction1
06- 34	Auto Run Mode Running Direction2
06- 35	Auto Run Mode Running Direction3
06- 36	Auto Run Mode Running Direction4
06- 37	Auto Run Mode Running Direction5
06- 38	Auto Run Mode Running Direction6
06- 39	Auto Run Mode Running Direction7
Range	【0】 : STOP 【1】 : Forward 【2】 : Reverse

- Auto Run sequencer mode has to be enabled by using one of the multifunctional inputs S1 to S5 and setting the relevant parameter 03-00 to 03-04 to selection 【18】 .
- Various Auto Run (sequencer) modes can be selected by parameter (06-00) as listed above.
- 7 Auto Run (sequencer) modes can be selected by parameters (06-01~06-39)
- Auto Run frequency commands1 to 7 are set with Parameters (06-01~06-07),

- Sequence run times are set with parameters (06-17~ 06-23)
- FWD/REV Direction for each sequence can be set with parameters (06-33 ~ 06-39).
- Auto sequence 0, frequency is set from keypad by parameter 05-01, sequence run time and direction are set by parameters 06-16 and 06-32.

Auto RUN (Auto Sequencer) examples are shown in the following pages:-

Example 1. Single Cycle (06- 00=1, 4)

The inverter will run for a single full cycle based on the specified number of sequences, then it will stop. In this example 4 sequences are set, three in forward direction and one in Reverse.

Auto Run Mode	06-00=1 or 4
Frequency	05-01=15Hz, 06-01=30Hz, 06-02=50Hz, 06-03=20Hz
Sequence Run Time	06-16=20s, 06-17=25s, 06-18=30s, 06-19=40s

Direction 06-32=1(FWD), 06-33=1(FWD), 06-34=1(FWD), 06-35=2(REV)
 Unused Sequence Parameters 06-04~06-07=0Hz, 06-20~06-23=0s, 06-36~06-39=0

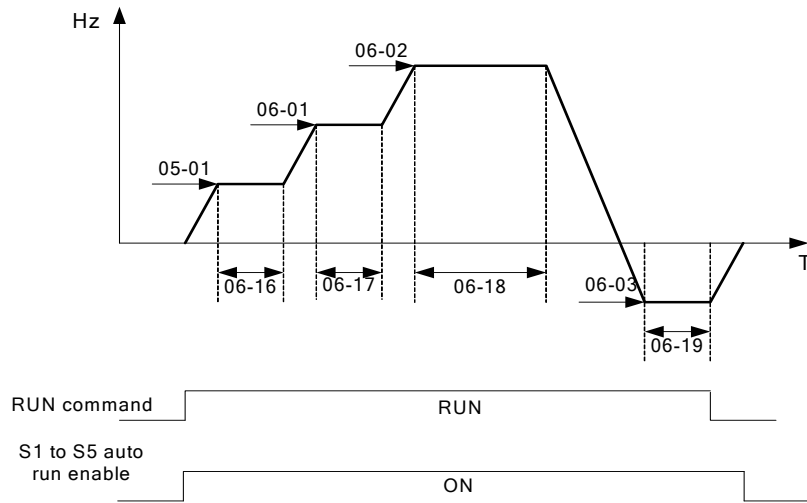

Example 2. Periodic cycle Run.

Mode: 06-00=2 or 5

The inverter will repeat the same cycle periodically.

All other Parameters are set same as Example 1. Shown above.

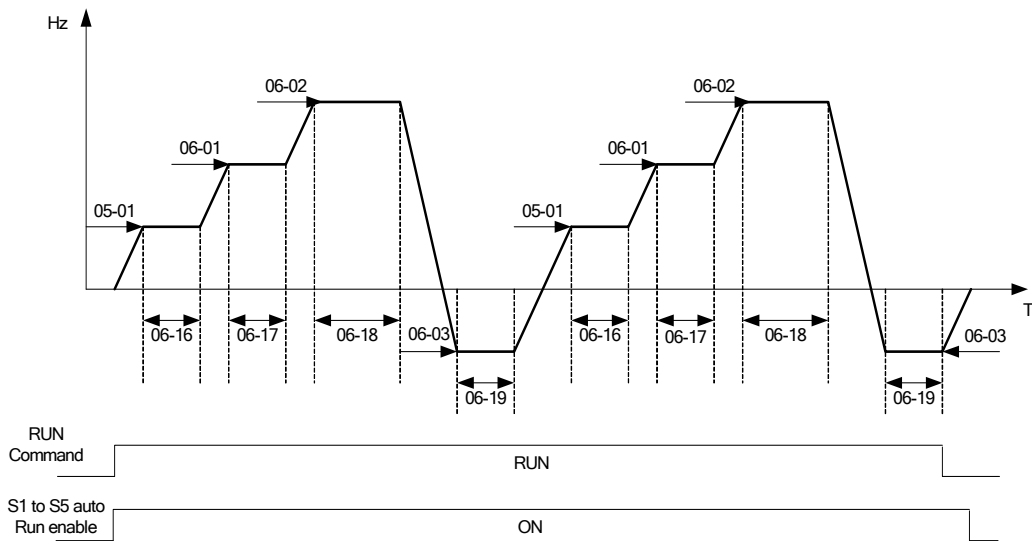

Example 3. Auto_Run Mode for Single Cycle 06-00=3 or 6

The speed of final step will be held to run.

Auto Run Mode 06-00=3 or 6
 Frequency 05-01=15Hz, 06-01=30Hz, 06-02=50Hz, 06-07=20Hz
 Sequence Run Time 06-16=20s, 06-17=25s, 06-18=30s, 06-23=40s
 Direction 06-32=1(FWD), 06-33=1, 06-34=1, 06-39=1
 Unused Sequence Parameters 06-03~06-06=0Hz, 06-19~06-22=0s, 06-35~06-38=0

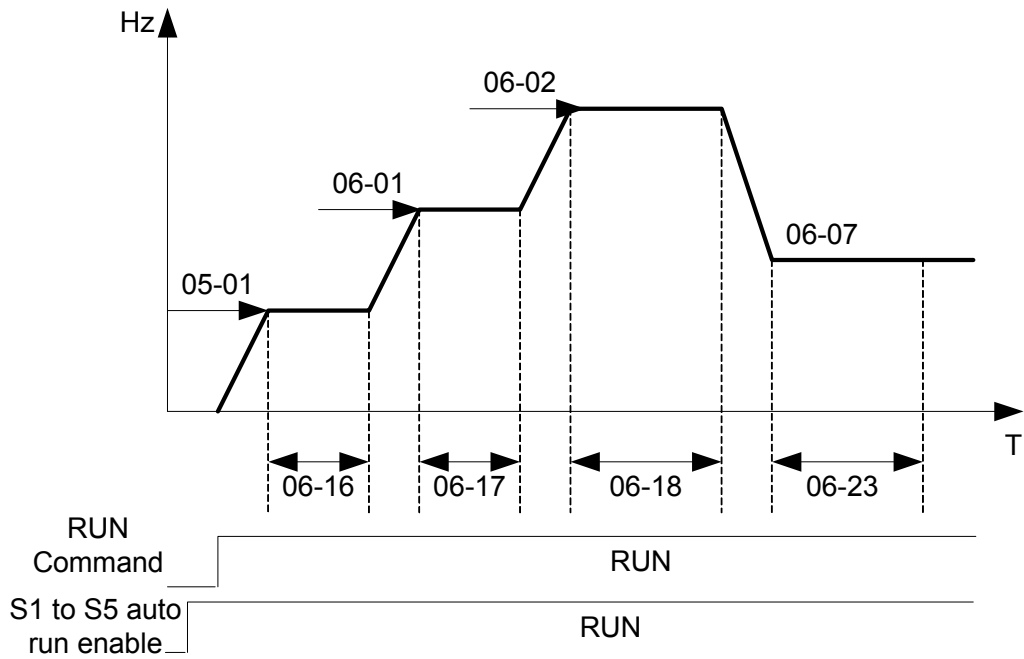

Example 4 & 5.

Auto Run Mode 06-00=1~3, after a restart continues to run from the unfinished step.

Auto Run Mode 06-00=4~6, after a restart, it will begin a new cycle.

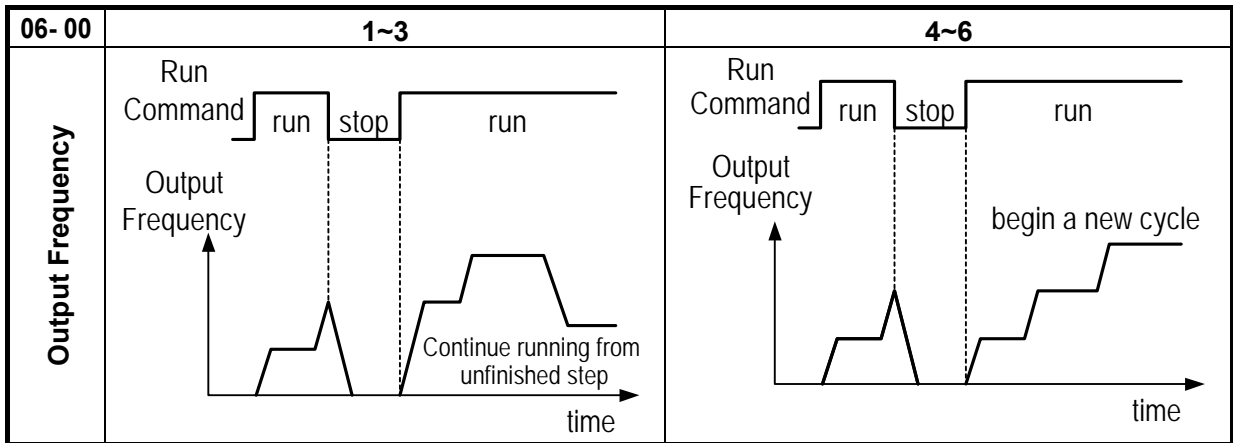

- ACC/DEC time in Auto run mode will be according to the setting of 00-14/00-15 or 00-16/00-17.
- For Auto sequence 0. The run frequency will be according to keypad frequency set by parameter 05-01. Parameters 06-16 and 06-32 are used to set the sequence Run time and Run direction.

07- Start/Stop command setup

07- 00	Momentary power loss and restart
Range	[0] :Momentary Power Loss and Restart disable [1] :Momentary power loss and restart enable

- If the input power supply due to sudden increase in supply demand by other equipment results in voltage drops below the under voltage level, the inverter will stop its output at once.
- When 07-00=0, on power loss, the inverter will not start.
- When 07-00=1, after a momentary power loss, inverter will restart with the same frequency before power loss, and there is no limitation on number of restarts.
- On power loss, as long as the inverter CPU power is not completely lost, the momentary power loss restart will be effective, restart will be according to setting of parameters 00-02 & 07-04 and status of External run switch.

Caution:

After any power loss if the Run mode is set to External by parameter 00-02=1 and if Direct start on power up is also selected by parameter 07-04=0, please note that the inverter will run on resumption of power.

To ensure safety of operators and to avoid any damages to the machinery, all necessary safety measure must be considered, including disconnection of power to the inverter.

07- 01	Auto Restart Delay Time
Range	[0.0~6000.0] Sec
07- 02	Number of Auto Restart Attempts
Range	[0~10]

- 07-02=0: The inverter will not auto restart after trips due to fault.
- 07-02>0, 07- 01=0, after a trip due to fault the inverter will run with the same frequency before power loss, and restarts after an internal delay of 0.5 seconds.
- 07-02>0, 07- 01>0, after a fault trip the inverter will run with the same frequency before power loss, and restart with a delay according the preset in parameter 07-01.
- The following faults can be auto restart: PDER, LV-C, OV-C, OC-S, OC-A, OC-d, OC-C and PF.
- **Note:**
Auto restart after a fault will not function while DC injection braking or decelerating to stop

07- 03	Reset Mode Setting
Range	[0] :Enable Reset Only when Run Command is Off [1] :Enable Reset when Run Command is On or Off

- 07-03=0 Once the inverter is detected a fault, please turn Run switch Off and then On again to perform reset, otherwise restarting will not be possible.

07- 04	Direct Running on Power Up
Range	[0] :Enable Direct running after power up [1] :Disable Direct running after power up

07-05	Delay-ON Timer (Seconds)
Range	[1.0~300.0] Sec

- When direct run on power up is selected by 07-04=0 and the inverter is set to external run by (00-02/00-03=1), if the run switch is ON as power is applied, the inverter will auto start. It is recommend that the power is turned off and the run switch is also off to avoid possibility of injury to operators and damage to machines as the power is reapplied.

Note: If this mode is required all safety measures must be considered including warning labels.

- When direct run on power up is disabled by 07-04=1 and if the inverter is set to external run by (00-02/00-03=1), if the run switch is ON as power is applied, the inverter will not auto start and the display will flash with STP1. It will be necessary to turn OFF the run switch and then ON again to start normally.

07-06	DC Injection Brake Start Frequency (Hz)
Range	[0.10 ~ 10.00] Hz

- When DC Injection braking is active DC voltage is applied to the motor, increasing the braking current and resulting in an increase in the strength of the magnetic field trying to lock the motor shaft.
- To enable DC injection braking during a stop operation set the DC injection braking current (07-07) and the DC injection braking time at stop (07-08) to a value greater than 0.

Notes:

- Increasing the DC braking time (07-08) can reduce the motor stop time
- Increasing the DC braking current (07-07) can reduce the motor stop time.
- During stop operation: If the DC braking start frequency < minimum output frequency (01-08), DC braking is activated when the output frequency reaches the minimum output frequency level.

07-07	DC Injection Brake Level (%)
Range	[0~ 20] %. based on the 20% of maximum output voltage

- In V/F mode, the value is equal to 0~20% of max output voltage(01-01)

07-08	DC Injection Brake Time (Sec)
Range	[0.0 ~ 25.5] Sec

- 07-08/07-06 set the DC injection brake duration and the brake start frequency as shown below.

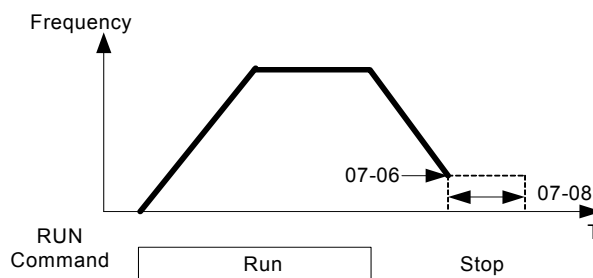

07-09	Stopping Method
Range	[0] :Deceleration to stop. [1] :Coast to stop.

- 07-09 = [0] : after receiving stop command, the motor will decelerate to stop according to setting of 00-15, deceleration time 1.
- 07-09 = [1] : after receiving stop command, the motor will free-run (Coast) to stop.

07- 10	DC Braking Level at Start
Range	【0~20】 % , based on the 20% of maximum output voltage

- In V/F mode, the value is equal to 0~20% of max output voltage(01-01)

07- 11	DC Braking Time at Start
Range	【0~25.5】 Sec

- When DC braking time reached, output frequency will be based on V/F curve.

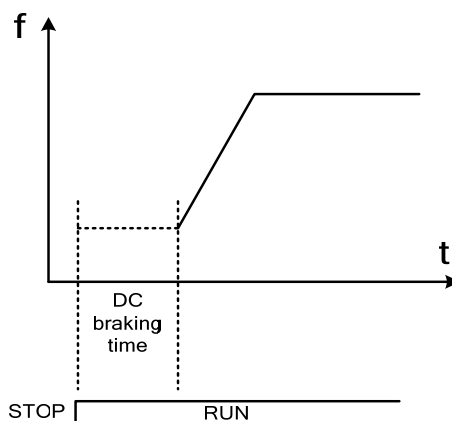

07- 12	Run Command Retention
Range	0: Run command retention during power loss 1: Run command not retained during power loss

- When 07-12=0, run command during inverter run is retained before power off. After power cecling, inverter start running automatically according to the frequency command which is retained before power off, no need to press “RUN” key again.
- When 07-12=1, run command during inverter run is not retained before power off. After power cecling, inverter start will not running to the frequency command which is retained before power off, need to press “RUN” key again.

08- Protection function group

08- 00	Trip Prevention Selection
Range	【xxxx0】 : Enable Trip Prevention During Acceleration 【xxxx1】 : Disable Trip Prevention During Acceleration 【xxx0x】 : Enable Trip Prevention During Deceleration 【xxx1x】 : Disable Trip Prevention During Deceleration 【xx0xx】 : Enable Trip Prevention in Run Mode 【xx1xx】 : Disable Trip Prevention in Run Mode 【x0xxx】 : Enable over voltage Prevention in Run Mode 【x1xxx】 : Disable over voltage Prevention in Run Mode

08- 01	Trip Prevention Level During Acceleration
Range	【 50 ~ 200 】 %

- Trip prevention adjustment level during acceleration to prevent over current (OC-A) trips.
- If trip prevention during acceleration is enabled and an over current occurs due to the load, then the acceleration is interrupted until the over current level is dropped below the setting in 08-01 then the acceleration is resumed.

08- 02	Trip Prevention Level During Deceleration
Range	【 50 ~ 200 】 %

- Trip prevention adjustment level during deceleration to prevent over Voltage (OV-C) trips.
- If trip prevention during deceleration is enabled and an over voltage occurs during stopping due to the load, then the deceleration is interrupted until the over voltage level is dropped below the setting in 08-02 then the deceleration is resumed.

08- 03	Trip Prevention Level during continuous Run Mode
Range	【 50 ~ 200 】 %

- Trip prevention adjustment level during continuous Run to prevent over current (OC-C) trips.
- If trip prevention during continuous Run is enabled and an over current occurs due the load such as a sudden transient load, then the output frequency is reduced by decelerating to a lower speed until the over current level is dropped below the preset in 08-03, then the output frequency accelerates back to the normal running frequency.

08- 04	Over voltage Prevention Level during Run Mode
Range	200: 【 350~390 】 VDC 400: 【 700~780 】 VDC

- Over voltage prevention level can be set by parameter 08-04 when necessary. When the DC bus voltage is higher than 08-04, inverter will keep running, the output frequency will be decreased once the DC bus voltage reduced. It's the over voltage prevention function, inverter will not appear any error message.
(If the DC bus voltage higher than OV protection level, inverter will appear "OV" message)

08- 05	Electronic Motor Overload Protection Operation Mode (OL1)
Range	xxxx0: Disable Electronic Motor Overload Protection xxxx1: Enable Electronic Motor Overload Protection xxx0x: Motor Overload Cold Start xxx1x: Motor Overload Hot Start xx0xx: Standard Motor xx1xx: Invertor Duty Motor (Force Vent)

Electronic Motor Overload Protection OL1 (08-05)

- When more than one motor is connected to the inverter set the Overload protection level parameter 02-01 to the total current of all motors and provide external overload relay protection for each motor.
- When using normal power supply switch, motor overload protection 08-05=xxx1x (hot start protection curve). Because whenever power is turned off, value of heat will return to default setting.
- 08-05 = xx0xx. (Standard motor Overload protection). For standard motors with integrated cooling fan when running at low speeds the heat dissipation is not very effective, consider Force vent cooling then set parameter 08-05=xx1xx for the correct overload protection.
- 08-05 = xxxx1: Enable electronic overload protection for motor according to Setting in parameter 02-01(motor rated current).
- Please refer to the curve in parameter 08-19, as an example for overload protection for a standard motor. (08-05=xx0xx)

08- 06	Operation After Overload Protection is Activated
Range	[0] : Coast-to-Stop After Overload Protection is Activated [1] : Drive Will Not Trip when Overload Protection is Activated (OL1)

- 08-06=0: On overload condition the inverter coast to stop as the thermal relay detects the overload and the display will flash OL1.To reset Press the 'Reset' key or use an external reset to continue to run.
- 08-06=1: On overload condition the inverter continues to run, display flash with OL1, until the current falls below the overload level.

08- 07	OH over heat Protection
Range	[0] :Auto (Depends on heat sink temp.) [1] :Operate while in RUN mode [2] :Always Run [3] :Disabled

- **08-07=0:** Cooling fan runs as the inverter detects temperature rise.
- **08-07=1:** Cooling fan runs while the inverter is running.
- **08-07=2:** Cooling fan runs continuously, about 10sec after the inverter is powered ON.
- **08-07=3:** Cooling fan is disabled.

08-08	AVR function
Range	【0】 : AVR function enable 【1】 : AVR function disable 【2】 : AVR function disable for stop 【3】 : AVR function disable for Deceleration 【4】 : AVR function disabled for stop & Deceleration from one speed to another speed. 【5】 : When VDC>(360V/740V), AVR function is disabled for stop and deceleration

- Automatic voltage regulator function provides a level of output voltage stability when there is input voltage instability. So when 08-08=0, Input voltage fluctuations will not affect the output voltage.
- 08-08=1, Input voltage fluctuations will cause fluctuations on output voltage.
- 08-08=2, AVR is disabled during stopping to avoid an increase in stopping time.
- 08-08=3, AVR is disabled only during deceleration from one speed to another speed. This will avoid longer than required deceleration time.
- 08-08=4, AVR function disabled for stop & Deceleration from one speed to another speed.
- 08-08=5, When VDC>360(200V series) or VDC>740V(400V series), AVR function is disabled for stop and deceleration

08-09	Input phase loss protection
Range	【0】 : Disabled 【1】 : Enabled

- When 08-09=1: On phase loss warning message PF is displayed.

08-10	PTC Motor Overheat Function
Range	【0】 : Disable 【1】 : Decelerate to stop 【2】 : Coast to stop 【3】 : Continue running, when warning level is reached. Coast to stop, when protection level is reached.
08-11	PTC Signal Smoothing Time
Range	【0.00 ~ 10.00】 Sec
08-12	PTC Detection Time Delay
Range	【1 ~ 300】 Sec
08-13	PTC Protection Level
Range	【0.1 ~ 10.0】 V
08-14	PTC Detection Level Reset
Range	【0.1 ~ 10.0】 V
08-15	PTC Warning Level
Range	【0.1 ~ 10.0】 V

➤ **Selection for motor overheat protection:**

PTC (Positive temperature coefficient) sensors are used in motor windings to provide additional motor protection from overheat.

PTC thermistor can be connected to terminals AVI and AGND.

A voltage divider resistor R is necessary to be connected as shown below in figure (b).

- 1) If 08-10 =1 or 2 (Decelerate or Cost to stop on over temperature detection). When over temperature is detected by signal at terminal AVI increasing above the warning detection limit

set in parameter 08-15 and the delay time set in parameter. 08-12 is reached, the display will show "OH4"(motor over heat detection), then output frequency will decelerate or coast to stop according to the selection 1 or 2.

- 2) If 08-10 = 3 Continue running when warning level is reached (08-15). Coast to stop when protection level is reached.(08-13).When over temperature is detected by signal at terminal AVI increasing above the Warning detection limit set in parameter 08-15, then the display will show "OH3"(motor over heat warning level) and the motor will continue to run. If temperature detected increases above the set limit in parameter 08-13 and for the delay time set in parameter 08-12 then the display will show "OH4" (motor over heat detection), and the motor will coast to stop.
- 3) Motor over heat detection "OH4" can be reset when the temperature detection level at terminal AVI becomes lower, then the set level in parameter 08-14.
- 4) External PTC thermistor characteristics

Diagram in figure (a) shows two curves for Class F and Class H temperatures.

Tr = 150°C in class F,

Tr = 180°C in class H.

Tr - 5°C: $R_{PTC} \leq 550\Omega$, put value of R_{PTC} into formula to calculate the value of V to be set in parameter 08-14.

Tr + 5°C: $R_{PTC} \geq 1330\Omega$, put value of R_{PTC} into formula to calculate, the value of V to be set in parameter 08-13.

- 5) For different specifications of PTC thermistor, set the values for parameters 08-13 and 08-14 by calculating from the formula shown below.

$$V = \frac{1}{2} \times 10 \times \frac{R_{PTC} // R_{in}}{R + (R_{PTC} // R_{in})}$$

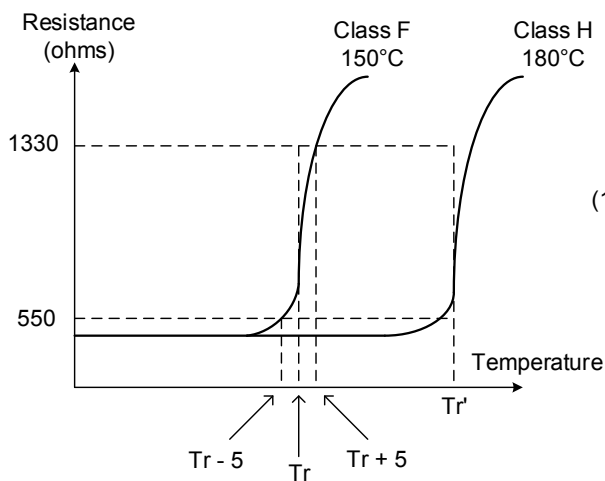

Tr : Temperature threshold value

(a) PTC Thermistor Characteristics

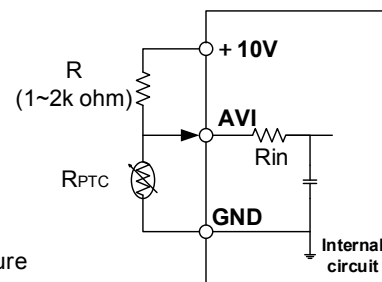

(b) PTC Thermistor Connections

Rin=164k ohm

08-16	Fan Control Temperature Level
Range	【10.0~50.0】 °C

- When 08-07=0 (Heat sink temperature detection control for cooling fan). Fan will run when temperature of heat sink is higher than 08-16; When temperature of heat sink decrease below "setting value of 08-16 minus 2°C", fan will stop.

08-17	Over current protection level
Range	【0.0~60.0】 A
08-18	Over current protection time
Range	【0.0~1500.0】 s

- When the output current exceeds the setting value of 08-17 and then keep running exceeds the setting value of 08-18, inverter will show "OL3" alarm and then stop running. (When the output current lower than the setting value of 08-17, 08-18 will be reset, over current protection function will be closed when 08-17 set to "0".)

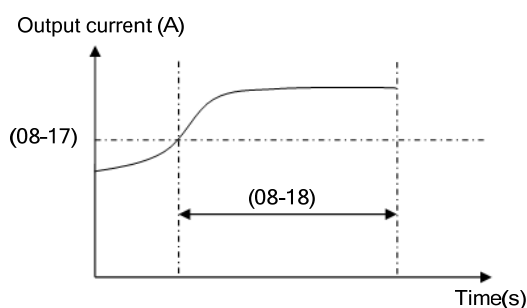

08-19	Motor Overload (OL1) Protection Level
Range	0 : Motor Overload Protection Level 0 1 : Motor Overload Protection Level 1 2 : Motor Overload Protection Level 2

Motor overload protection level (08-05)

- Set motor overload protection level according to current motor nameplate.
- Turn off the motor overload protection when using two or more motors connected to the inverter (set 08-05 = xx0b), and provide external overload protection for each motor (e.g. thermal overload switch).
- When 08-05=xx1xb (Hot start), the value of hot start will be reset once power-off.
- The motors without cooling fan (general standard motor), heat dissipation of lower speed is low, 08-05 can be set to x0xxb.
- The motors with cooling fan (special motor or V/F motor), heat dissipation is not related with output speed, 08-05 can be set to x1xxb.
- To use the built-in motor overload protection function parameter 02-01 (motor rated current) has to match the motor rated current on the motor nameplate.
- Refer to the following examples (08-05=x0xxb) and the overload curves will be based on parameter setting of 08-19.

When 08-19=0:

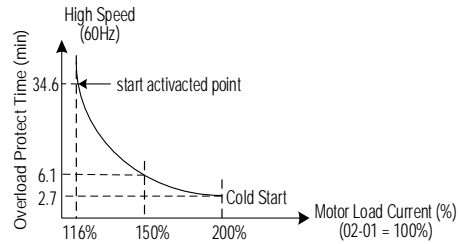
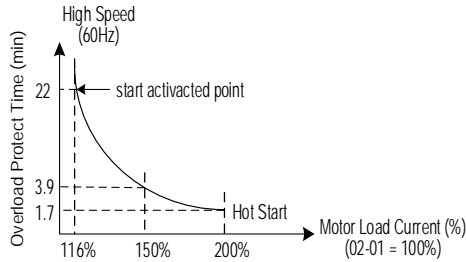
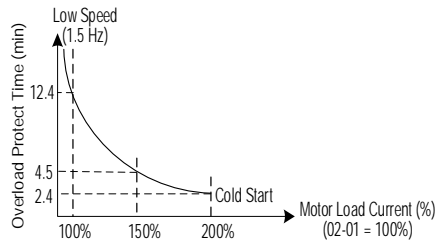
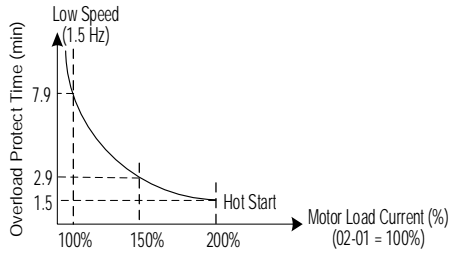

When 08-19=1:

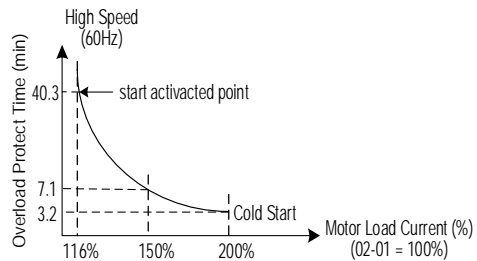
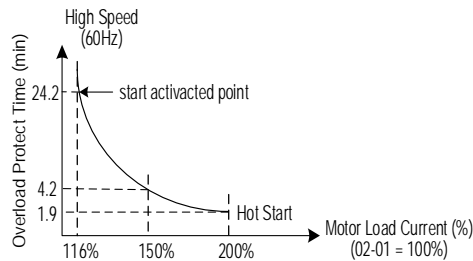
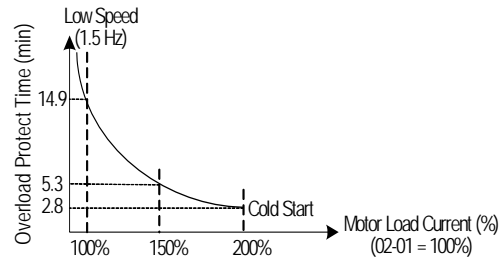
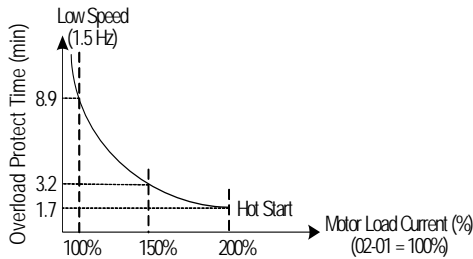

When 08-19=2:

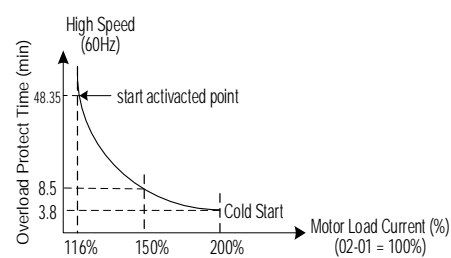
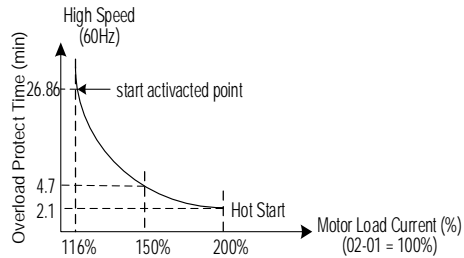
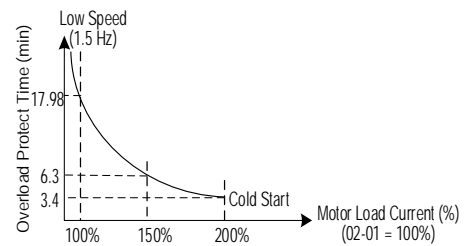
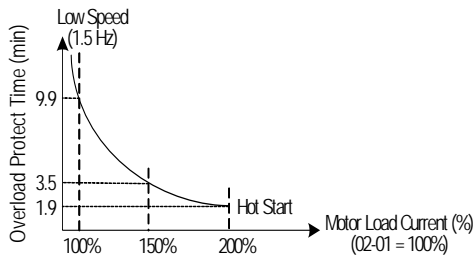

Motor overload curves (for general motor)

09- Communication function group

09- 00	Assigned Communication Station Number
Range	[1 ~ 32]

- 09-00 sets the communication station number when there are more than one unit on the communication network. Up to 32 Slave units can be controlled from one master controller such as a PLC.

09- 01	Communication Mode Select
Range	[0] : RTU [1] : ASCII
09- 02	Baud Rate Setting (bps)
Range	[0] : 4800 [1] : 9600 [2] : 19200 [3] : 38400

- When 09-02 is changed, please re-connect the input power again.

09- 03	Stop Bit Selection
Range	[0] :1 stop bit [1] :2 stop bit
09- 04	Parity Selection
Range	[0] :no parity [1] :even parity [2] :odd parity
09- 05	Data Format Selection
Range	[0] :8 bit data [1] :7 bit data
09- 06	Communication time-out detection time
Range	[0.0~25.5] Sec

- 09-06 is against communication test messages. When a test message is not responded within the time specified by 09-06, Inverter will be stopped according to the setting of 09-07, and then appear "COT" on keypad display. Once the 09-06=0, inverter will not appear "time-out".
- Time-out detection time: 00.0~25.5 seconds; setting 00.0 seconds: disables time-out function.

09- 07	Communication time-out operation selection
Range	[0] :Stop in deceleration time 1 and show COT after communication timeout [1] :Stop in free run mode and show COT after communication timeout [2] :Stop in deceleration time 2 and show COT after communication timeout [3] :Keep running and show COT after communication timeout

09- 08	Err6 fault tolerance times
Range	[0~20]

- 09-08 is against real communication messages. When a real message does not pass error check, that message is resent. The number of errors for the same message are counted and accumulated and if it reaches the setting of 09-08, L510s will show Err6 and stop according to the setting of 07-09.

09-09	Drive Transmit Wait Time
Range	[5~65] 2ms

- This parameter is used to set the converter to receive data from the sending date to the beginning of the time.

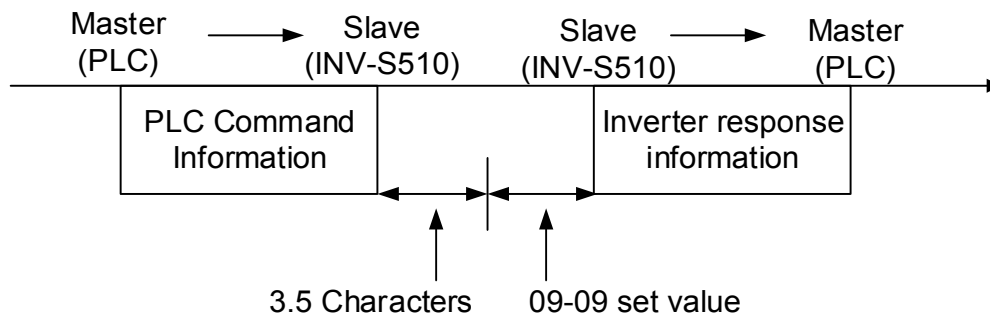

10-PID function Setup

PID block diagram

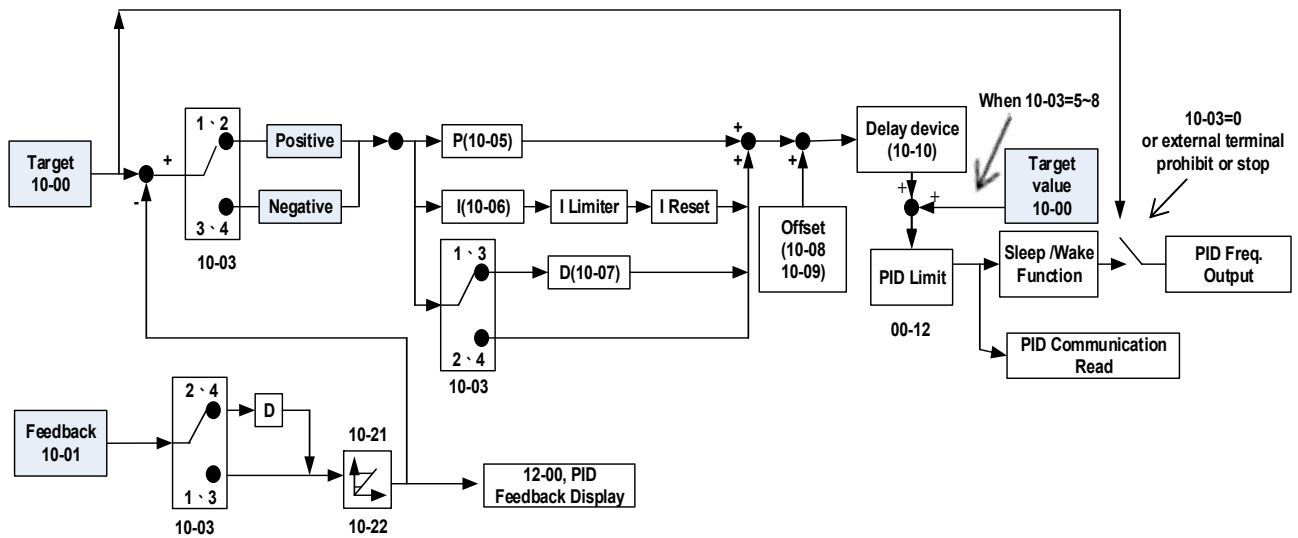

10- 00	PID target value selection
Range	<p>[0] : Reserved</p> <p>[1] : External AVI/ACI Analog Signal Input</p> <p>[2] : Reserved</p> <p>[3] : Target Frequency set by Communication method.</p> <p>[4] : Set from keypad by parameter 10-02.</p> <p>[5] : Set from preset frequency.</p>

- 10-00 selections are only effective when frequency source selection is set to PID by parameters 00 - 05 / 00 - 06= 6.
- When 10-00=5, PID target value is set according to Parameter Group 05 “preset frequency”.
Ex : When 00-05=6, 10-00=5, 10-03=1, 03-00=2, 03-01=3, 03-02=4, turn on S1~S3 sequentially (0 : OFF, 1 : ON), please check the output frequency on display is consistent with the 05-01 ~ 05-08.

	S1	S2	S3
	03-00=2	03-01=3	03-02=4
Preset frequency 0 (05-01)	0	0	0
Preset frequency 1(05-02)	1	0	0
Preset frequency 2(05-03)	0	1	0
Preset frequency 3(05-04)	1	1	0
Preset frequency 4(05-05)	0	0	1
Preset frequency 5(05-06)	1	0	1
Preset frequency 6(05-07)	0	1	1
Preset frequency 7(05-08)	1	1	1

10- 01	PID feedback value selection
Range	<p>[0] : Potentiometer on Keypad</p> <p>[1] : External AVI Analog Signal Input</p> <p>[2] : External ACI Analog Signal Input</p> <p>[3] : Communication setting Frequency</p>

- ! Note: 10-00 and 10-01 can not be set to the same value.

10- 02	PID keypad input
Range	【0.0~100.0】 %
10- 03	PID operation selection
Range	【0】 : PID Function disabled 【1】 : FWD Characteristic. (Deviation is D-controlled) 【2】 : FWD Characteristic. (Feedback is D-controlled) 【3】 : REV Characteristic. (Deviation is D-controlled) 【4】 : REV Characteristic. (Feedback is D-controlled) 【5】 : FWD Characteristic. (Frequency Command +Deviation D Control) 【6】 : FWD Characteristic. (Frequency Command + Feedback D Control) 【7】 : Reverse characteristic. (Frequency Command + Deviation D Control) 【8】 : Reverse characteristic. (Frequency Command + Feedback D Control)

➤ 10-03=1

Ddeviation (target - detected value) is derivative controlled in unit time set in parameter 10-07.

➤ 10-03=2

Feedback (detected value) is derivative controlled in unit time set in parameter 10- 07.

➤ 10-03=3

Ddeviation (target value - detected value) is derivative controlled in unit time set in parameter 10- 07. If the deviation is positive, the output frequency decreases, vice versa.

➤ 10-03=4

Feedback (detected value) is derivative controlled in unit time set in parameter 10- 07.

If the deviation is positive, the output frequency decreases, vice versa.

➤ 10-03=5~8

Output frequency=PID output frequency + frequency command (10-03=1~4).

10- 04	Feedback Gain coefficient
Range	【0.00 ~ 10.00】

➤ 10-04 is the calibration gain. Deviation = set point – (feedback signal×10-04)

10- 05	Proportional Gain
Range	【0.0 ~ 10.0】

➤ 10- 05: Proportion gain for P control.

10- 06	Integral Time
Range	【0.0 ~ 100.0】 s

➤ 10- 06: Integration time for I control

10- 07	Derivative Time
Range	【0.00 ~ 10.00】 s

➤ 10- 07: Differential time for D control

10- 08	PID Offset
Range	【0】 : Positive Direction 【1】 : Negative Direction

10- 09	PID Offset Adjust
Range	【0 ~ 109】 %

➤ 10-08/10-09: Calculated PID output is offset by 10-09 (the polarity of offset is according to10-08)

10-10	PID Output Lag Filter Time
Range	[0.0 ~ 2.5] s

- 10-10: Update time for output frequency.

10-11	Feedback Loss Detection Mode
Range	[0] : Disable [1] : Drive keeps running After Feedback Loss [2] : Drive Stops After Feedback Loss

- **10-11=1: On feedback loss** detection, continue running, and display 'PDER'.
- **10-11=2: On feedback loss** detection, stop, and display 'PDER'.

10-12	Feedback Loss Detection Level
Range	[0 ~ 100]

- 10-12 is the level for signal loss. Error = (Set point – Feedback value). When the error is larger than the loss level setting, the feedback signal is considered lost.

10-13	Feedback Loss Detection Delay Time
Range	[0.0 ~25.5] s

- 10-13: The minimum time delay before feedback signal loss is determined.

10-14	Integration Limit Value
Range	[0 ~ 109] %

- 10-14: The Limiter to prevent the PID from saturating.

10-15	Integration Value Resets to Zero when Feedback Signal Equals the target Value
Range	[0] : Disabled [1] : After 1 Sec [30] : After 30 Sec (Range:- 1 ~ 30 Sec)

- 10-15=0, as PID feedback value reaches the set point, the integral value will not be reset.
- 10-15=1~30, as PID feedback value reaches the set point, reset to 0 in 1~30 seconds and inverter stops. The inverter will run again when the feedback value differs from the set point value.

10-16	Allowable Integration Error Margin (Unit) (1 Unit = 1/8192)
Range	[0 ~ 100] %

- 10-16= 0~100% unit value: Restart the tolerance after the integrator reset to 0.

10-17	PID Sleep Frequency Level
Range	[0.00~599.00] Hz
10-18	PID Sleep Function Delay Time
Range	[0.0 ~25.5] s
10-19	PID Wake up frequency Level
Range	[0.00 ~ 599.00] Hz
10-20	PID Wake up function Delay Time
Range	[0.0 ~ 25.5] s

- When PID output frequency is less than the sleep threshold frequency and exceeds the time of sleep delay, the inverter will decelerate to 0 and enters PID sleep mode.
- When PID output frequency is larger than the Wake up threshold frequency inverter will enter the PID mode again as shown in the timing diagram below.

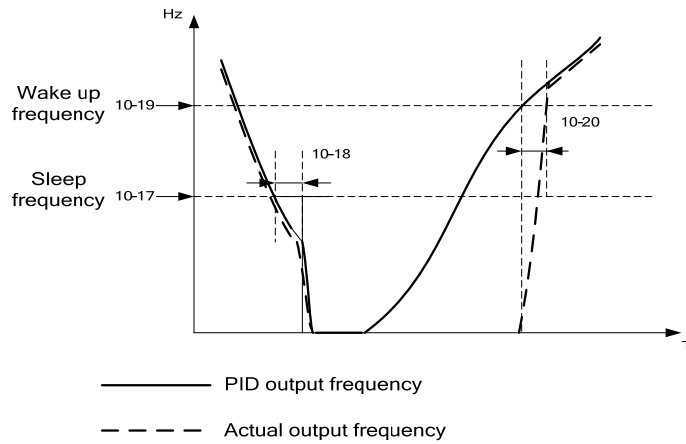

10-21	Max PID Feedback Level.
Range	[0 ~ 999]
10-22	Min PID Feedback Level.
Range	[0 ~ 999]

- Example: If 10-21=100 and 10-22=50 and the unit for the range from 0 to 999 will be defined with the parameters setting of 12-02 , actual feedback value variation range, will be scaled to 50 and 100 only for display, as Shown below.

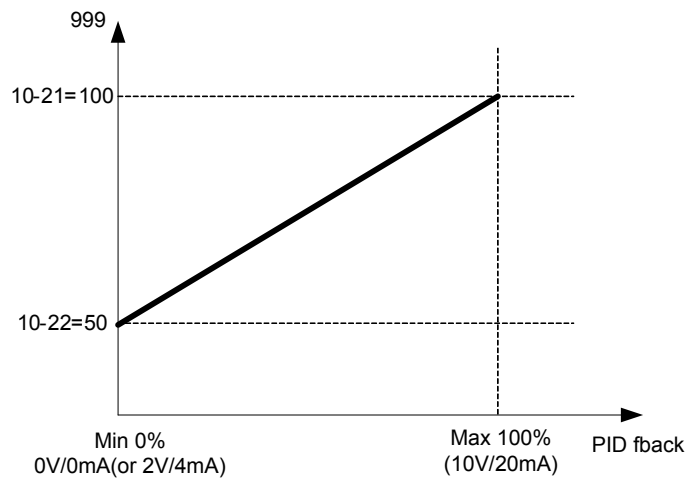

11 Performance control functions

11- 00	Prevention of Reverse operation
Range	[0] :Reverse command is valid [1] :Reverse command is invalid

- When 11-00=1, inverter did not accept reverse operation command.

11- 01	Carrier Frequency
Range	[1~16] KHz

- Setting range from 1 to 16 represents KHz.
- A low carrier frequency decreases RFI, EMI interference and motor leakage current.
- A low carrier frequency increases motor noise, but reduces motor losses and temperature.
- If cable length between the inverter and the motor is too long, the high-frequency leakage current will cause an increase in inverter output current, which might affect peripheral devices.

11- 02	Carrier mode selection
Range	[0] :Carrier mode0 3-phase PWM modulation [1] :Carrier mode1 2-phase PWM modulation [2] :Carrier mode2 Random PWM modulation

The function can be used for audible noise reduction from a motor. It can be used in cases where the 100% torque from motor is not critical but it is necessary to reduce the audible noise.

➤ **Mode 0 (3-phase PWM Modulation).**

Three Output transistors are ON at the same time (Full Duty). Carrier frequency is set according to Parameter 11-01

➤ **Mode 1 (2-phase PWM Modulation)**

Two output transistors are ON at the same time (2/3 Duty). This mode is suitable for variable torque applications such as Fan & pump. It reduces the output transistor switching losses. Carrier frequency will be according to parameter 11-01 with the exception noted below:

➤ **Mode 2 (Random PWM Modulation).**

This modulation method will use 3-phase PWM and 2-phase PWM modulation in a random combination. Carrier frequency will be according to parameter 11-01

PWM mode selection considerations:

Modes	Name	IGBT Duty	Heat Losses	Torque Performance	Waveform Distortion	Motor Noise
0	3-Phase PWM	100%	High	High	Low	Low
1	2-Phase PWM	66.6%	Low	Low	High	High
2	2-Phase Random PWM	66.6%	Low	Low	High	Mid

11- 03	Carrier Frequency auto reduction due to temperature rise
Range	[0] : Disable [1] : Enable

- If inverter (heat sink) temperature rises above 80°C the carrier frequency is reduced by 4K.
- If the temperature falls below less than 70°C, carrier frequency is restore to the value of **11-01**.
- Temperature can be displayed by setting parameter 12-00=04000.

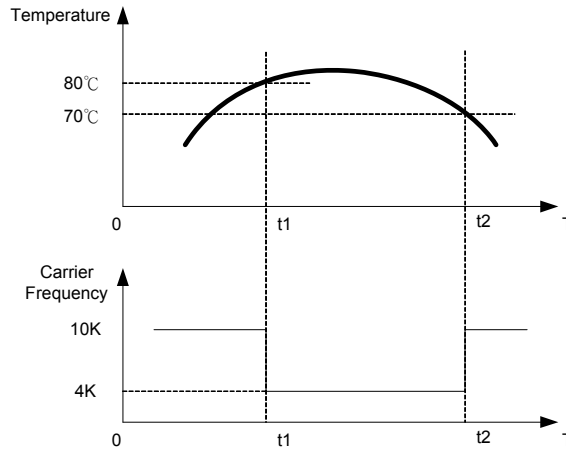

11-04	S-Curve Acc 1
11-05	S-Curve Acc 2
11-06	S-Curve Dec 3
11-07	S-Curve Dec 4
Range	【0.0 ~ 4.0】 s

- Use S Curve parameters where a smooth acceleration or deceleration action is required, this will prevent possible damage to driven machines by sudden acceleration/deceleration.

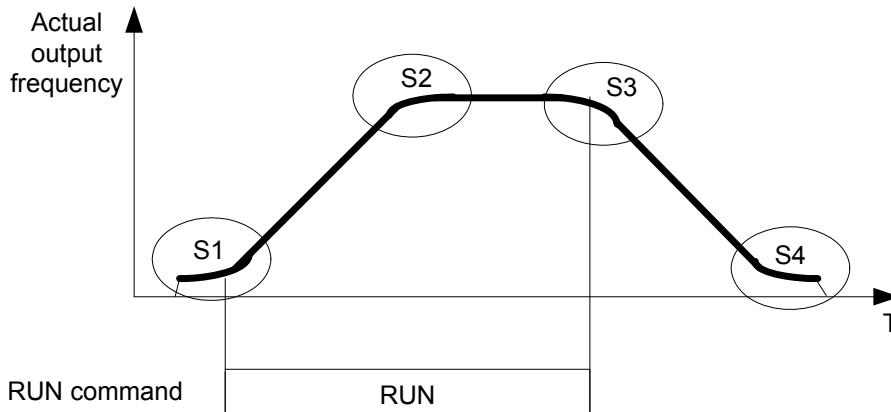

Note:

- Regardless of the stall prevention period, please refer as below.
 Actual acceleration time = preset acceleration time + ((11-04) + (11-05))/2.
 Actual deceleration time = preset deceleration time + ((11-06) + (11-07))/2.
- Please set the required individual S curve times in the parameters (11-04~11-07).
- When S curve time (11-04~11-07) is set as 0, the S curve function is disabled.

11-08	Skip frequency 1
11-09	Skip frequency 2
11-10	Skip frequency 3
Range	【0.00 ~ 599.00】 Hz
11-11	Skip frequency range. (± frequency band)
Range	【0.00 ~ 30.00】 Hz

Skip frequency parameters can be used to avoid mechanical resonance in certain applications.
 Example: 11-08=10.00(Hz); 11-09=20.00(Hz); 11-10=30.00(Hz); 11-11=2.00(Hz).

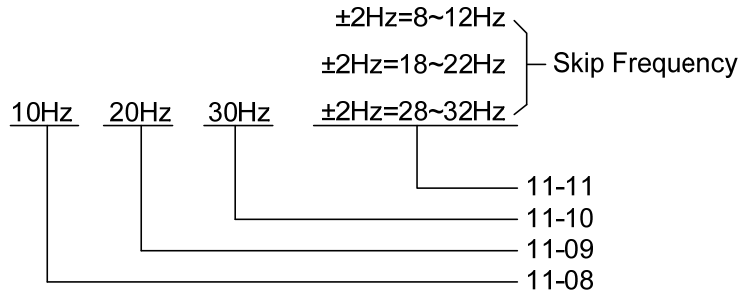

11-13	Regeneration Prevention Function
Range	【0】 : The function is disabled 【1】 : The function is enabled 【2】 : The function is enabled only during constant speed

➤ **Regeneration Prevention Function:**

During excessive energy regeneration, the Vpn (DC bus) voltage will increase and lead to OV (over voltage), to avoid over voltage due to regeneration the output frequency will be increased. Regeneration prevention function can be set according to the selections above.

Example: Regeneration prevention during acceleration.

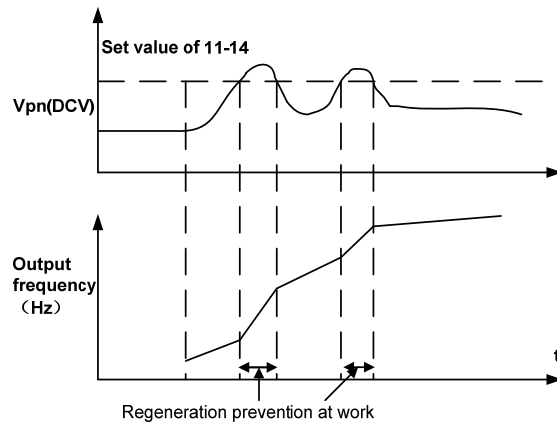

Example: Regeneration prevention during constant speed.

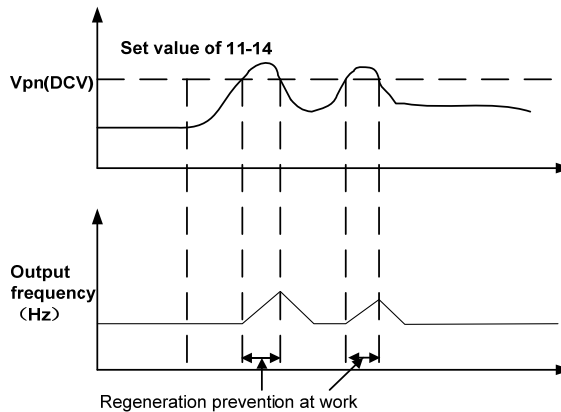

Example: Regeneration prevention during deceleration.

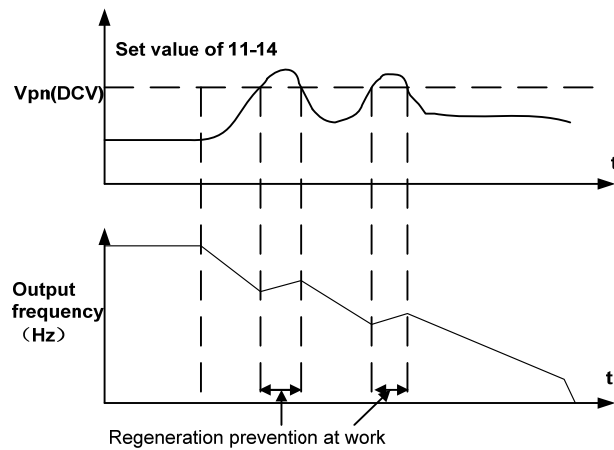

11-14	Regeneration Prevention Voltage Level
Range	200v: 300.0~400.0 V 400v: 600.0~800.0 V

- If the DC bus voltage level is set too low, then over-voltage protection will not be reached, but the actual deceleration time will be extended.

11-15	Regeneration Prevention Frequency Limit
Range	【0.00~15.00】 Hz

- Sets the regeneration prevention frequency limit.

11-16	Regeneration Prevention Voltage Gain
Range	【0~200】 %
11-17	Regeneration Prevention Frequency Gain
Range	【0~200】 %

- 11-16/11-17 represent the effect for regeneration prevention. It will enhance the response of DC bus voltage variation by enlarging the setting. However, it will lead to instability of output frequency.
- If setting 11-16 to be smaller still can't suppress the shake, please set 11-17 to be smaller.

11-21	Stop Key Selection
Range	【0】 : Enable Stop Key when Run Command not from Keypad 【1】 : Disable Stop Key when Run Command not from Keypad

- When run command comes from control terminal (00-02=1) or communication (00-02=2), this parameter can be enabled or disabled the stop key function of operator.

12 Monitor function group

12- 00	Display Mode
Range	<p style="text-align: center;">0 0 0 0 0</p> <p style="text-align: center;">MSD LSD</p> <p>00000~66666 Each digit can be set from 0 to 6 as listed below.</p> <p>[0] : Disable display</p> <p>[1] : Output Current</p> <p>[2] : Output Voltage</p> <p>[3] : DC voltage</p> <p>[4] : Heat Sink Temperature</p> <p>[5] : PID feedback</p> <p>[6] : AVI/ACI value</p>

- MSD= Most significant digit. LSD= Least significant digit.
- Note: MSD of parameter 12-00 sets the power on display, other digits set user selected displays. (refer to P4-4)

12- 01	PID Feedback Display Mode
Range	<p>[0] : Displayed in Integer (xxx)</p> <p>[1] : Displayed with One Decimal Place (xx.x)</p> <p>[2] : Displayed with Two Decimal Places (x.xx)</p>
12- 02	PID Feedback Display Unit Setting
Range	<p>[0] : -----</p> <p>[1] : xxxpb (pressure)</p> <p>[2] : xxxfl (flow)</p>
12- 03	Custom Units (Line Speed) Display Mode
Range	[0~65535] rpm

- Set motor rated RPM in this parameter if required then the display will show this value when inverter output frequency reaches the motor name plate frequency. 50Hz or 60 Hz as appropriate.
- The line speed display is linearly proportional to the output frequency 0 to 50Hz or 0-60 Hz as appropriate. Motor synchronous speed = 120 x Rated frequency/Number of poles.

12- 04	Custom Units (Line Speed) Display Mode
Range	<p>[0] : Drive Output Frequency is Displayed</p> <p>[1] : Line Speed is Displayed in Integer (xxxxx)</p> <p>[2] : Line Speed is Displayed with One Decimal Place (xxxx.x)</p> <p>[3] : Line Speed is Displayed with Two Decimal Places (xxx.xx)</p> <p>[4] : Line Speed is Displayed with Three Decimal Places (xx.xxx)</p>

- **12- 04≠0**, line speed is displayed while the inverter is running or stopped.

12- 05	Input and output terminal status display
Range	Read only (Panel read only)

- When any of S1~S4 is turned on, corresponding segments on the digital display will be on.
- When relay output RY1 is on, the corresponding digit will be on as shown below.
- When no Digital input and no relay output, they will show - - - - - .

Example 1: The following figure shows 12 - 05 display status,
 When S1, S3, S5 Inputs are ON and S2, S4 and RY1 are OFF.

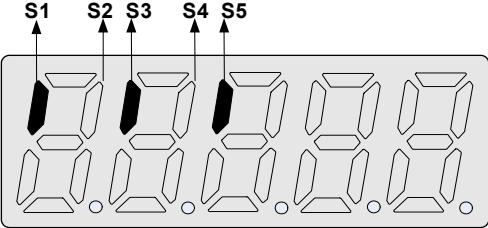

Example 2: The following figure shows 12 - 05 display status
 When S2, S3, S4 inputs are ON and S1, S5 are OFF but RY1 is ON.

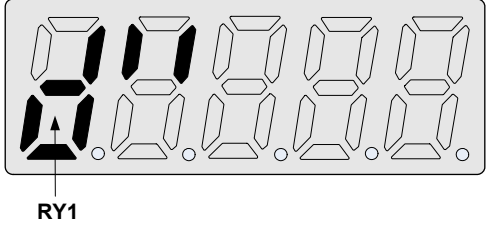

12- 06	Output Power
Range	----

➤ It needs to set motor rated power correctly (parameter 02-05)

12- 07	Motor Current Percentage
Range	----

➤ The ratio of drive output current and motor rated current, it needs to set motor rated current correctly (parameter 02-01)

13 Inspection & Maintenance functions

13- 00	Drive Horsepower Code
Range	----

Inverter Model:	13- 00 show	Inverter Model:	13- 00 show
S510-2P5-XXX	2P5	S510-401-XXX	401
S510-201-XXX	201	S510-402-XXX	402
S510-202-XXX	202	S510-403-XXX	403
S510-203-XXX	203	S510-405-XXX	405

13- 01	Software Version
Range	----
13- 02	Fault Log Display (Latest 3 faults)
Range	----

- Last three faults are stored in a stack and whenever there is a new fault the previous faults are pushed down the stack. So the fault stored in 2.xxx will be transferred to 3.xxx, and the one in 1.xxx to 2.xxx. The recent fault will be stored in the empty register 1.xxx.
- Use ▲ and ▼ keys to scroll between the fault registers.
- Pressing reset key when parameter 13-02 is displayed then all three fault registers will be cleared and the display for each register will change to 1. ---, 2. ---, 3. ---.
- E.g. fault log content is '1.OC-C'; this indicates the latest fault is OC-C, etc.

13- 03	Accumulated Inverter Operation Time 1
Range	[0~23] Hours
13- 04	Accumulated Inverter Operation Time 2
Range	[0~65535] Days
13- 05	Accumulated Inverter Operation Time Mode
Range	[0] :Power on time [1] :Operation time

- When the operation time recorded in accumulator 1(Parameter 13-03) reaches 24 hours
- The recorded value in accumulator 2 parameter 13-04 changes to 1 day and the value in accumulator 1 is reset to 0000.

13- 06	Parameter lock
Range	[0] : Enable all Functions [1] : Preset speeds 05- 01~05- 08 cannot be changed [2] : All Functions cannot be changed Except for preset speeds set in 05-01~05- 08 [3] : Disable All Function Except 13-06

- When the 13-07=00000, you can adjust the parameters 05-01~05-08 from 13-06.

13- 07	Parameter Lock Key Code
Range	[00000~65535]

- When parameter 13-07 is entered, all the parameters can not be modified. For any modification, the parameter lock key code has to unlock. Setting Parameter lock key number example:-

Step1:

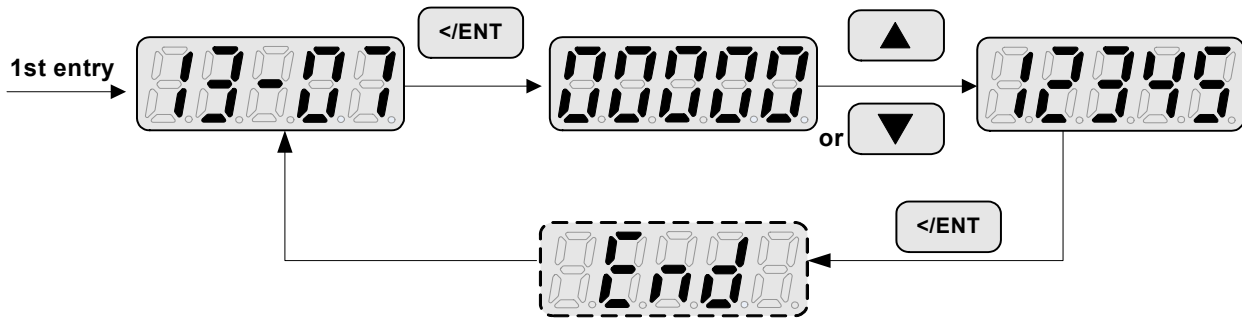

Step2:

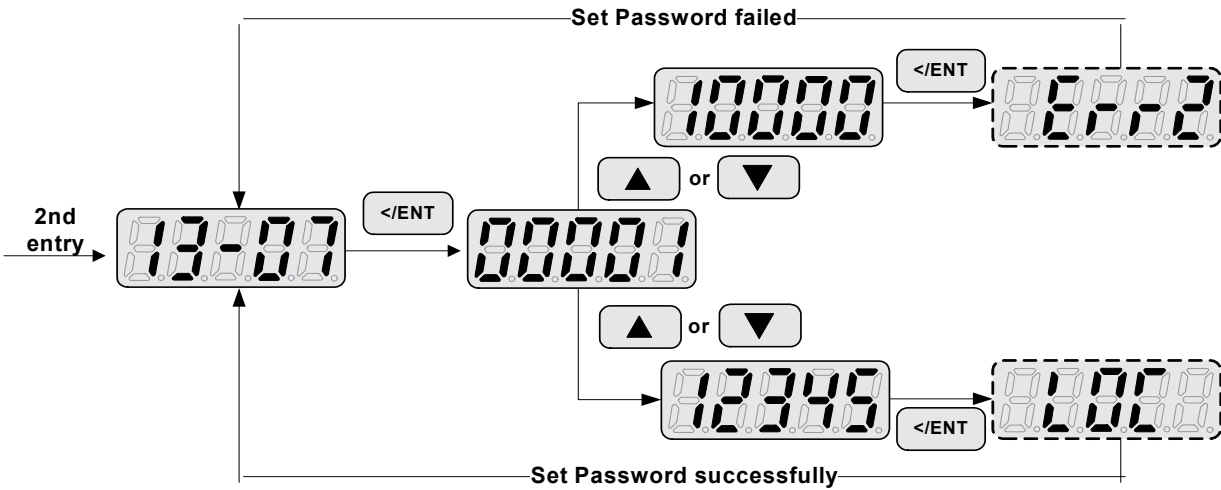

Key code (password) unlock

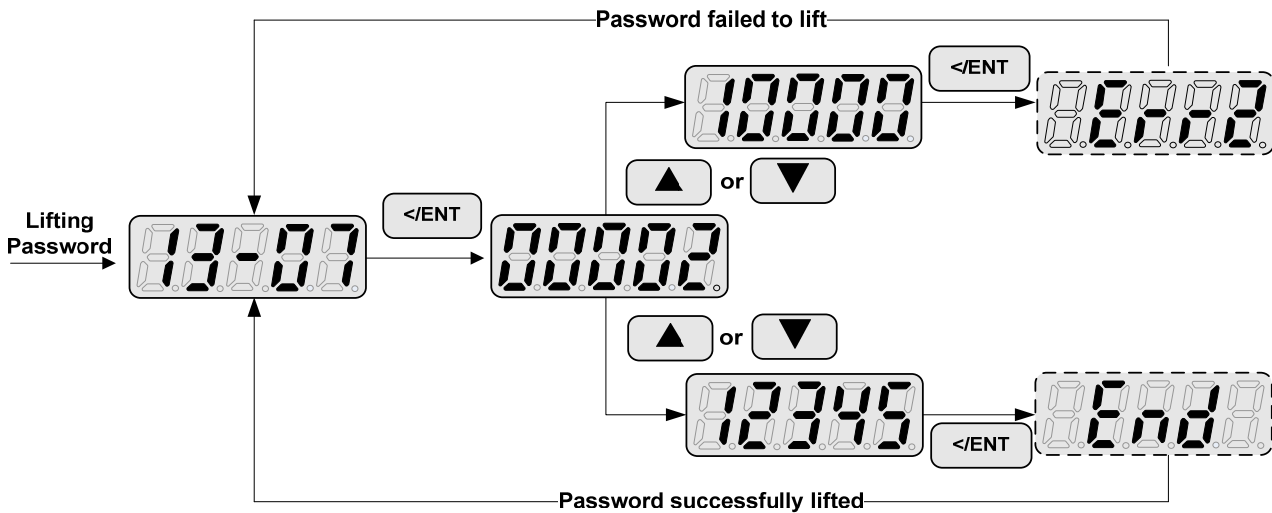

13- 08	Reset Drive to Factory Settings
Range	<p>【1150】 : Initialization (50Hz,220V/380V system)</p> <p>【1160】 : Initialization (60Hz,220V/380V system)</p> <p>【1250】 : Initialization (50Hz,230V/400V system)</p> <p>【1260】 : Initialization (60Hz,230V/460V system)</p> <p>【1350】 : Initialization (50Hz,220V/415V system)</p> <p>【1360】 : Initialization (60Hz,230V/400V system)</p>

- When a Parameter lock key number has been entered in parameter 13-07. This key number must be entered first before parameter 13-08 can be used.
- Reset 13-08 to default setting will reset parameter 02 group.
- For built-in EMC filter models, the default setting of 13-08 is “1250”.
For without built-in EMC filter models, the default setting of 13-08 is “1360”

13- 09	Parameters Function Display
Range	【0】 : Complete Parameters Group 【1】 : Simple Parameters Group

- Use 13-09 parameter to switch between complete parameter group (13-09=0) and simple parameters group (Default, 13-09=1).

Chapter 5 Troubleshooting and maintenance

5.1 Error display and corrective action

5.1.1 Manual Reset and Auto-Reset

Faults which cannot be recovered manually			
Display	Content	Cause	Corrective action
-OV- -OU-	Voltage too high when stopped	Detection circuit malfunction	Consult with the supplier
-LV- -LU-	Voltage too low when stopped	<ul style="list-style-type: none"> Power voltage too low Pre-charge resistor or fuse burnt out. Detection circuit malfunction 	<ul style="list-style-type: none"> Check if the power voltage is correct failed resistor or fuse Consult with the supplier
-OH- -OH-	The inverter is overheated when stopped	<ul style="list-style-type: none"> Detection circuit malfunction Ambient temperature too high or bad ventilation 	Improve the ventilation conditions, if no result then replace the inverter
OH-C OH-C	The inverter is overheated during running	<ul style="list-style-type: none"> IGBT temperature is too high or poor ventilation Temperature sensor error or circuit malfunctions 	<ul style="list-style-type: none"> Reduce carrier frequency Improve the ventilation conditions, if no result then replace the inverter
CtEr CtEr	Current Sensor detection error	Current sensor error or circuit malfunction	Consult with the supplier
HPErr HPErr	Inverter capacity setting error: Inverter capacity setting 13-00 does not match the rated voltage.	The inverter capacity setting (13-00) does not match the hardware voltage levels	Check the inverter capacity setting (13-00) to meet the hardware voltage levels.
Err4 Err4	CPU Unusual interruption	External noise interference	<ul style="list-style-type: none"> Remove the interference source then restart by switching power OFF/ON If not resolved then consult with the supplier
EPr EPr	EEPROM problem	Faulty EEPROM	Consult with the supplier
COt COt	Communication error	Communications disruption	Check the wiring

Faults which can be recovered manually and automatically			
Display	Content	Cause	Corrective action
OC-A OC-A	Over-current at acceleration	<ul style="list-style-type: none"> • Acceleration time too short • The capacity of the motor exceeds the capacity of the inverter • Short circuit between the motor coil and the case • Short circuit between motor wiring and ground • IGBT module damaged 	<ul style="list-style-type: none"> • Set a longer acceleration time • Replace inverter with one that has the same rating as that of the motor • Check the motor • Check the wiring • Consult with the supplier
OC-C OC-C			
OC-d OC-d	Over-current at deceleration	The preset deceleration time is too short.	Set a longer deceleration time
OC-S OC-S	Over current at start	<ul style="list-style-type: none"> • Short circuit between the motor coil and the case • Short circuit between motor coil and ground • IGBT module damaged 	<ul style="list-style-type: none"> • Inspect the motor • Inspect the wiring • Consult with the supplier
OV-C OV-C			
PF PF	Input phase Loss	Abnormal fluctuations in the main circuit voltage	<ul style="list-style-type: none"> • Check the main circuit power supply wiring. • Check the power supply voltage

Faults which can be recovered manually but not automatically			
Display	Content	Cause	Corrective action
OC OC	Over-current during stop	Detection circuit malfunction	Consult with the supplier
OL1 OL1	Motor overload	loading too large	Consider increasing the Motor capacity
OL2 OL2	Inverter overload	Excessive Load	Consider increasing the inverter capacity
CL CL	Inverter over current: Wait 1 minute to reset .If it occurs CL or OL2 up to 4 successive times then wait 5 mins to reset	inverter over current warning: inverter current reach the level of over current protection	Check load condition and running period time.
LV-C LV-C	Voltage too low during operation	1. Power voltage too low 2. Power voltage varies widely (fluctuates)	1. Improve power quality 2. Consider adding a reactor at the power input side
OVSP OVSP	motor rotation over speed	The actual rotation speed is different to the set speed.	1. Check for excessive load 2. Check weather frequency setting signal is right or not
OH4 OH4	motor over heat error	1. If temperature detected increases above the set limit in parameter 08-13 and for the delay time set in parameter 08-12 then the display will show "OH4" (motor over heat detection), and the motor will coast to stop. 2. Motor over heat detection "OH4" can be reset when the temperature detection level is lower than the set level in parameter 【08-14 PTC reset level】 .	1.To improve the ventilation condition 2. Adjust parameter 08-15

5.1.2 Keypad Operation Error Instruction

Display	content	Cause	Corrective action
LOC	1. Parameter already Locked 2. Motor direction locked 3. Parameter password (13-07) enabled	1. Attempt to modify frequency parameter while 13-06>0. 2. Attempt to reverse direction when 11-00=1. 3. Parameter (13-07) enabled, set the correct password will show LOC.	1.Adjust 13-06 2.Adjust 11-00
LOC			
Err1	Keypad operation error	1. 1.Press ▲ or ▼ while 00-05/00-06 > 0 or running at preset speed. 2. Attempt to modify the parameter can not be modified during operation (refer to the parameter list)	1. The ▲ or ▼ is available for modifying the parameter only when 00-05/00-06=0 2. Modify the parameter in STOP mode.
Err1			
Err2	Parameter setting error	1. 00-13 is within the range of (11-08 ±11-11) OR (11-09 ±11-11) OR (11-10 ±11-11) 2. 00-12 ≤ 00-13 3. 00-05/00-06 or 10-00/10-01 set the same value 4. Modifying parameters 01-01 to 01-09 when 01-00≠7. 5. If this parameter is parameterized for both functions (AVI/PTC) at the same time ; PTC function is enabled by setting 08-10≠0; 6. Parameter password (13-07) set incorrect	1. Modify 11-08~11-10 or 11-11 2. 00-12>00-13 3. Set 00-05 / 00-06 or 10-00 / 10-01 to be different value 4. Set 01-00=7 5. PTC function source can not be the same as frequency source or PID command via AVI. 6. Please set correct password
Err2			
Err5	Modification of parameter is not available in communication	1. Control command sent during communication. 2. Attempt to modify the function 09-02~ 09-05 during communication	1. Issue enable command before communication 2. Set parameters 09-02~ 09-05 function before communication
Err5			
Err6	Communication failed	1. Wiring error 2. Communication parameter setting error. 3. Incorrect communication protocol 4. Communication ground disconnected 5. External noise	1. Check hardware and wiring 2. Check Functions(09-00~09-05). 3. CON2 needs to connect to the earth. 4. Please increase the setting value of 09-08
Err6			
Err7	Parameter conflict	1. Attempt to modify the function 13-00/13-08. 2. Voltage and current detection circuit is abnormal.	If reset is not possible, please consult with the supplier.
Err7			

5.1.3 Special conditions

Display	Fault	Description
StP0 5LP0	Zero speed at stop	In V/f mode, STP0 comes out at less than 1.3Hz (50Hz set) or at less than 1.5Hz (60Hz set) In SLV mode, STP0 comes out at less than 1Hz
StP1 5LP1	Fail to start directly On power up.	1. If the inverter is set for external terminal control mode (00-02/00-03=1) and direct start is disabled (07-04=1) 2. The inverter cannot be started and will flash STP1. 3. The run input is active at power-up, refer to descriptions of (07-04).
StP2 5LP2	Keypad Stop Operated when inverter in external Control mode.	1. If the Stop key is pressed while the inverter is set to external control mode (00-02/00-03=1) then 'STP2' flashes after stop. 2. Release and re-activate the run contact to restart the inverter.
E.S. E.S.	External Rapid stop	When external rapid stop input is activated the inverter will decelerate to stop and the display will flash with E.S. message.
b.b. b.b.	External base block	When external base block input is activated the inverter stops immediately and then the display will flash with b.b. message.
PdEr PdEr	PID feedback loss	PID feedback loss is detected.
Alter ALtEr	auto tuning error	other errors show up in the process of auto tuning.
OH3 OH3	motor over heat warning	If 08-10 = 3. When over temperature is detected by signal at terminal AVI increasing above the warning detection limit set in parameter 08-15, then the display will show "OH3"(motor over heat warning level) and the motor will continue to run.

5.1.4 No Keypad Model Error Code Instruction

LED : ALM

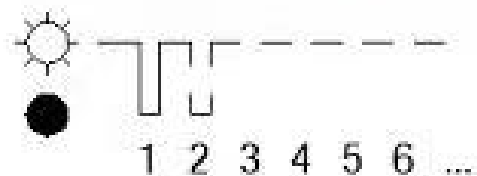

Alarm codes / Flash number:

- Flash 1 time: Over Voltage
- Flash 2 times: Low Voltage
- Flash 3 times: Over Current
- Flash 4 times: Motor Overload
- Flash 5 times: Inverter Overload
- Flash 6 times: Over Temperature
- Flash 7 times: Emergency Stop
- Flash 8 times: Communication Error

5.2 General troubleshooting

Status	Checking point	Remedy
Motor runs in wrong direction	Is the wiring for the output terminals correct?	Wiring must match U, V, and W terminals of the motor.
	Is the wiring for forward and reverse signals correct?	Check for correct wiring.
The motor speed can not be regulated.	Is the wiring for the analog frequency inputs correct?	Check for correct wiring.
	Is the setting of operation mode correct?	Check the Frequency Source set in parameters 00-05/00-06.
	Is the load too excessive?	Reduce the load.
Motor running speed too high or too low	Check the motor specifications (poles, voltage...) correct?	Confirm the motor specifications.
	Is the gear ratio correct?	Confirm the gear ratio.
	Is the setting of the highest output frequency correct?	Confirm the highest output frequency
Motor speed varies unusually	Is the load too excessive?	Reduce the load.
	Does the load vary excessively?	<ol style="list-style-type: none"> 1. Minimize the variation of the load. 2. Consider increasing the capacities of the inverter and the motor.
	Is the input power unstable or is there a phase loss ?	<ol style="list-style-type: none"> 1. Consider adding an AC reactor at the power input side if using single-phase power. 2. Check wiring if using three-phase power
Motor can not run	Is the power connected to the correct L1, L2, and L3 terminals? Is the charging indicator lit ?	<ol style="list-style-type: none"> 1. Is the power applied? 2. Turn the power OFF and then ON again. 3. Make sure the power voltage is correct. 4. Make sure screws are secured firmly.
	Is there voltage across the output terminals T1, T2, and T3?	Turn the power OFF and then ON again.
	Is overload causing the motor to stall?	Reduce the load so the motor will run.
	Are there any abnormalities in the inverter?	See error descriptions to check wiring and correct if necessary.
	Is there a forward or reverse run command ?	
	Has the analog frequency signal been input?	<ol style="list-style-type: none"> 1. Is analog frequency input signal wiring correct? 2. Is voltage of frequency input correct?
	Is the operation mode setting correct?	Operate through the digital keypad

5.3 Troubleshooting of the Inverter

5.3.1 Quick troubleshooting of the Inverter

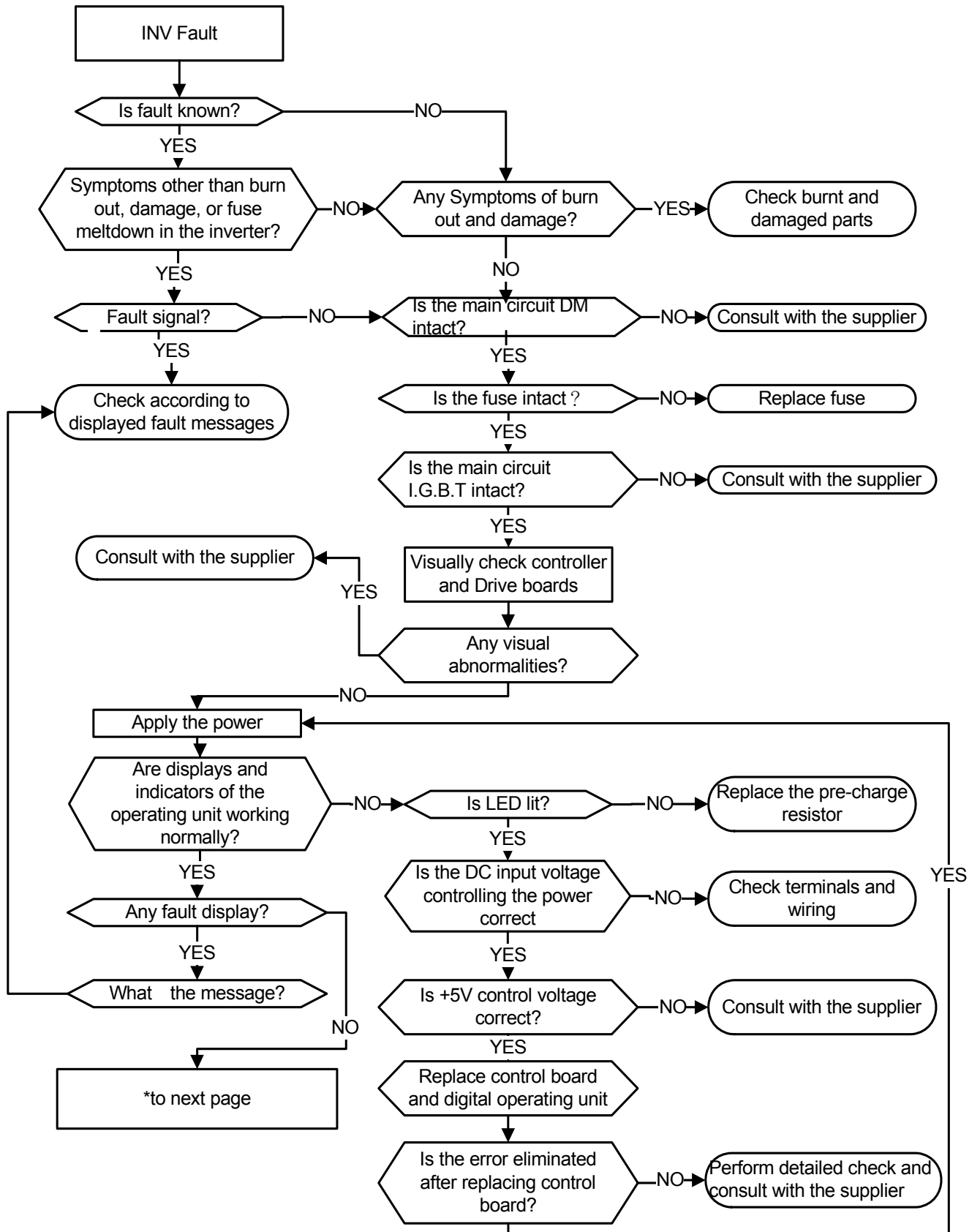

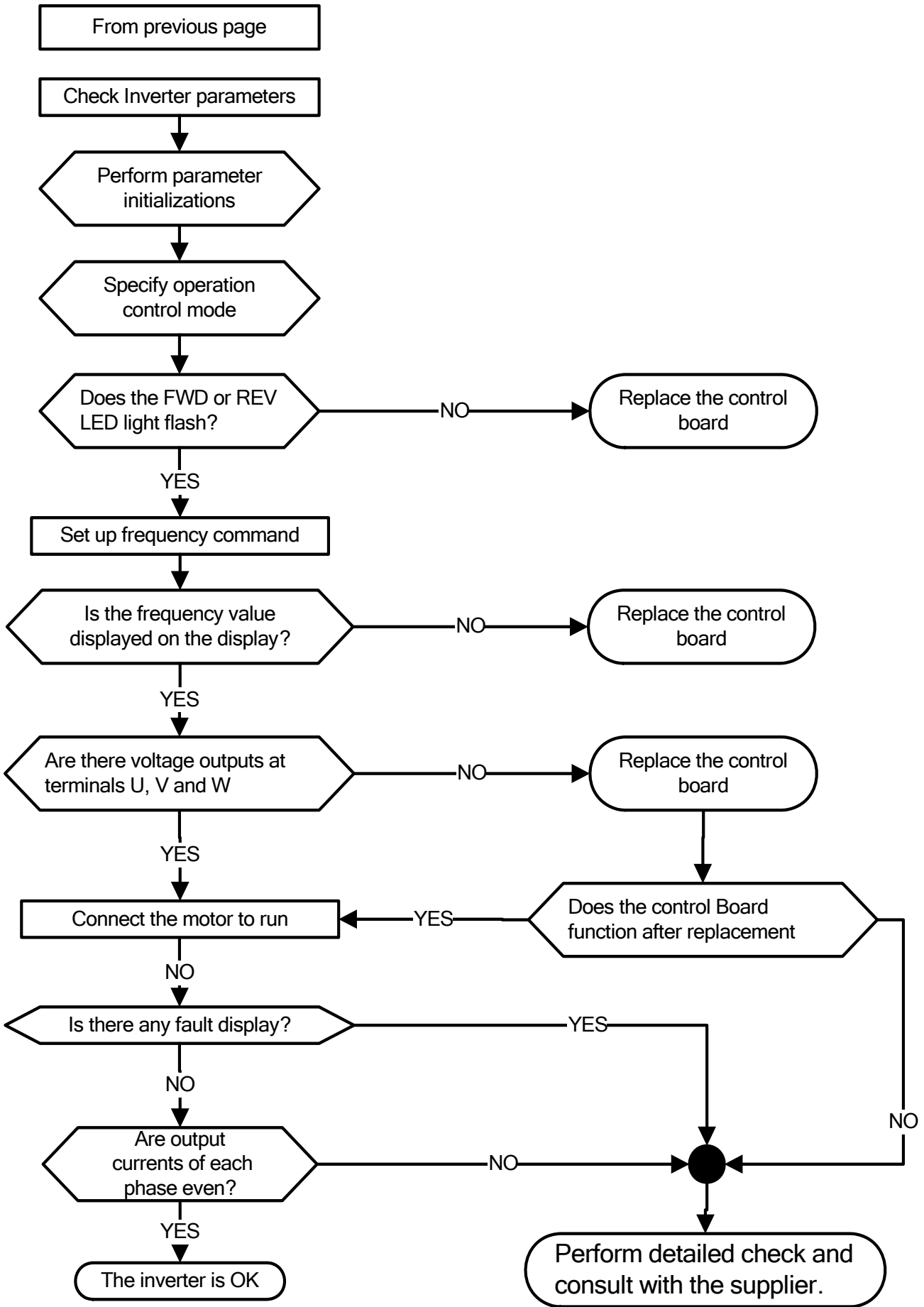

5.3.2 Troubleshooting for OC, OL error displays

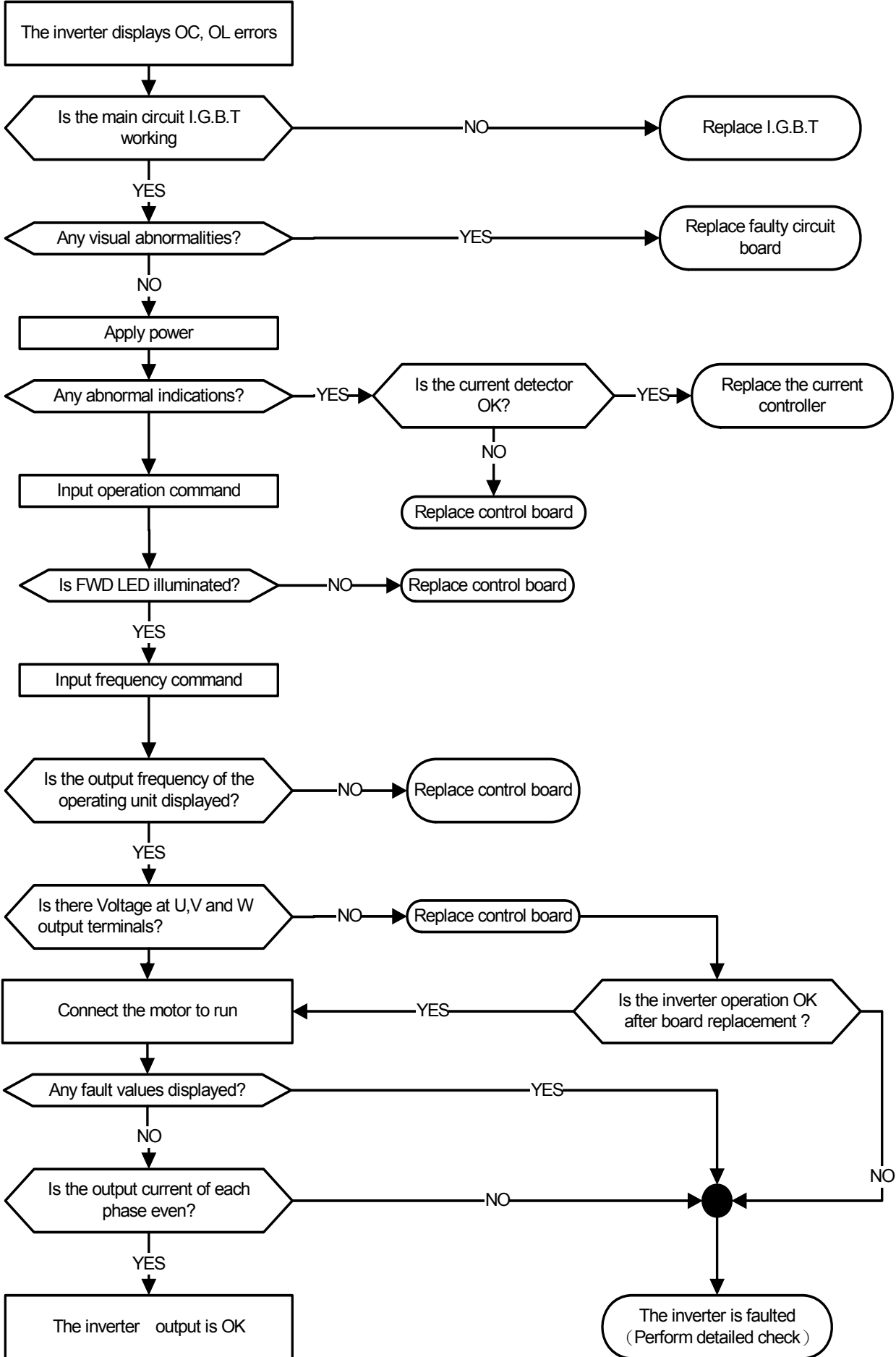

5.3.3 Troubleshooting for OV, LV error

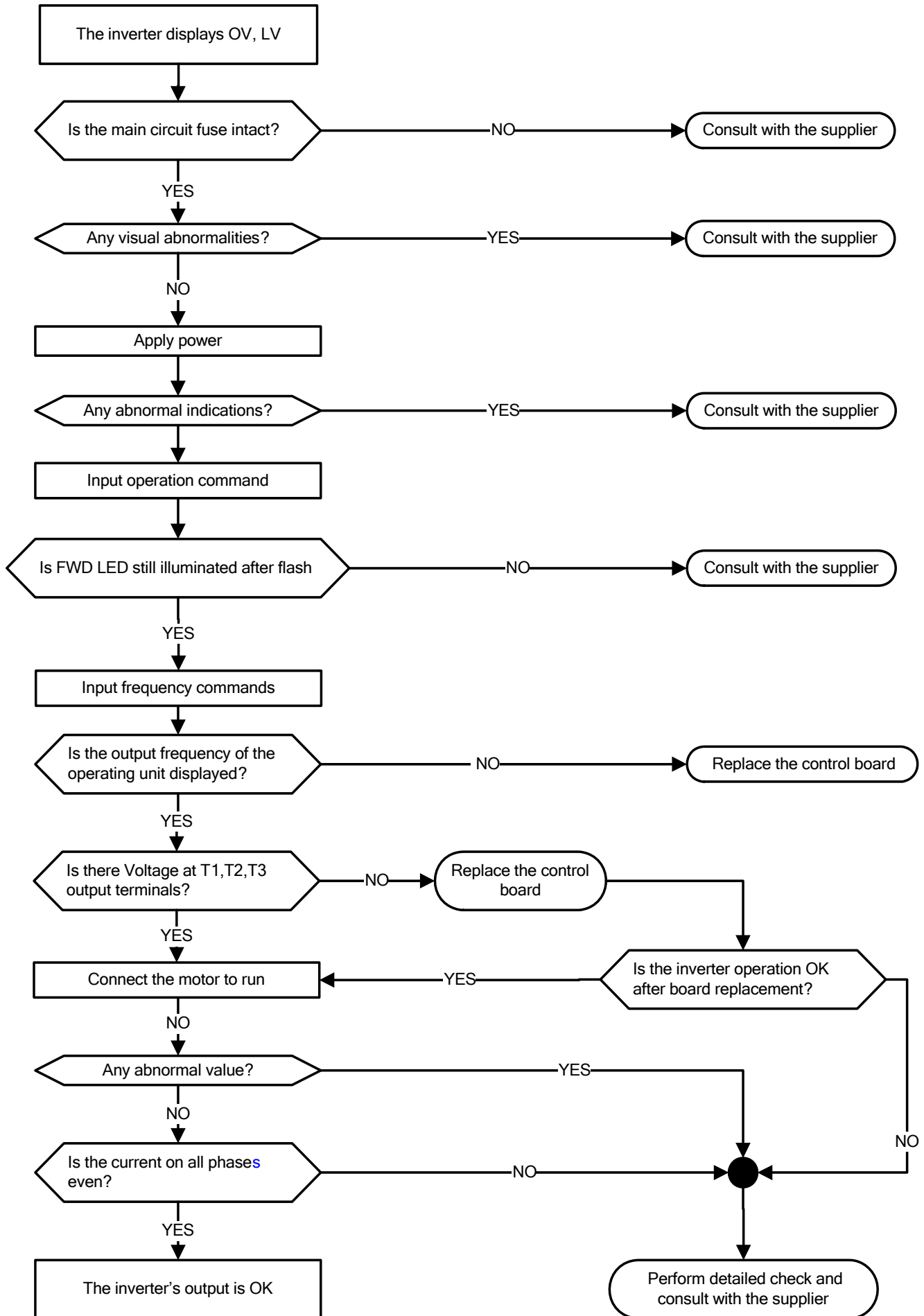

5.3.4 The motor can not run

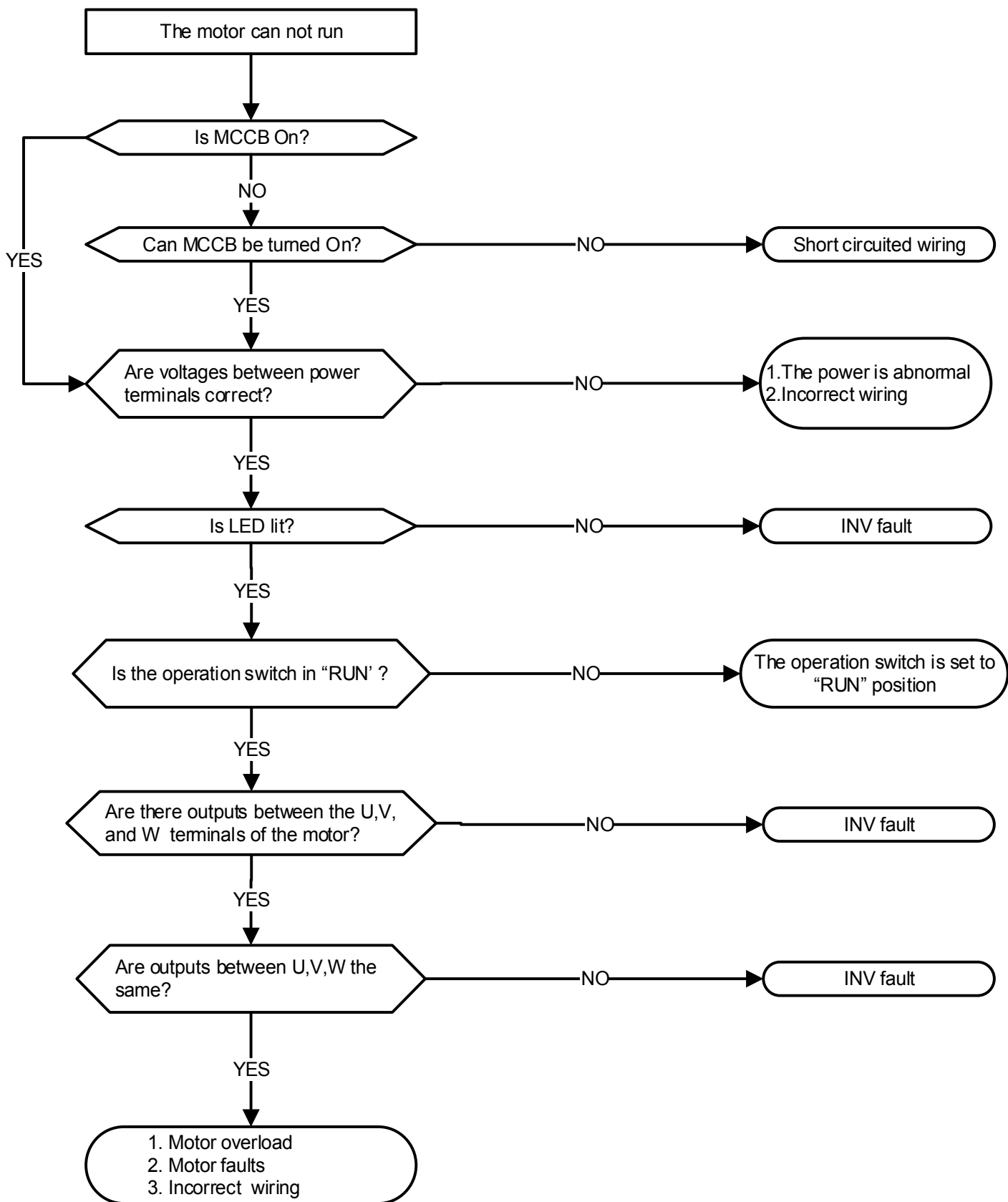

5.3.5 Motor Overheating

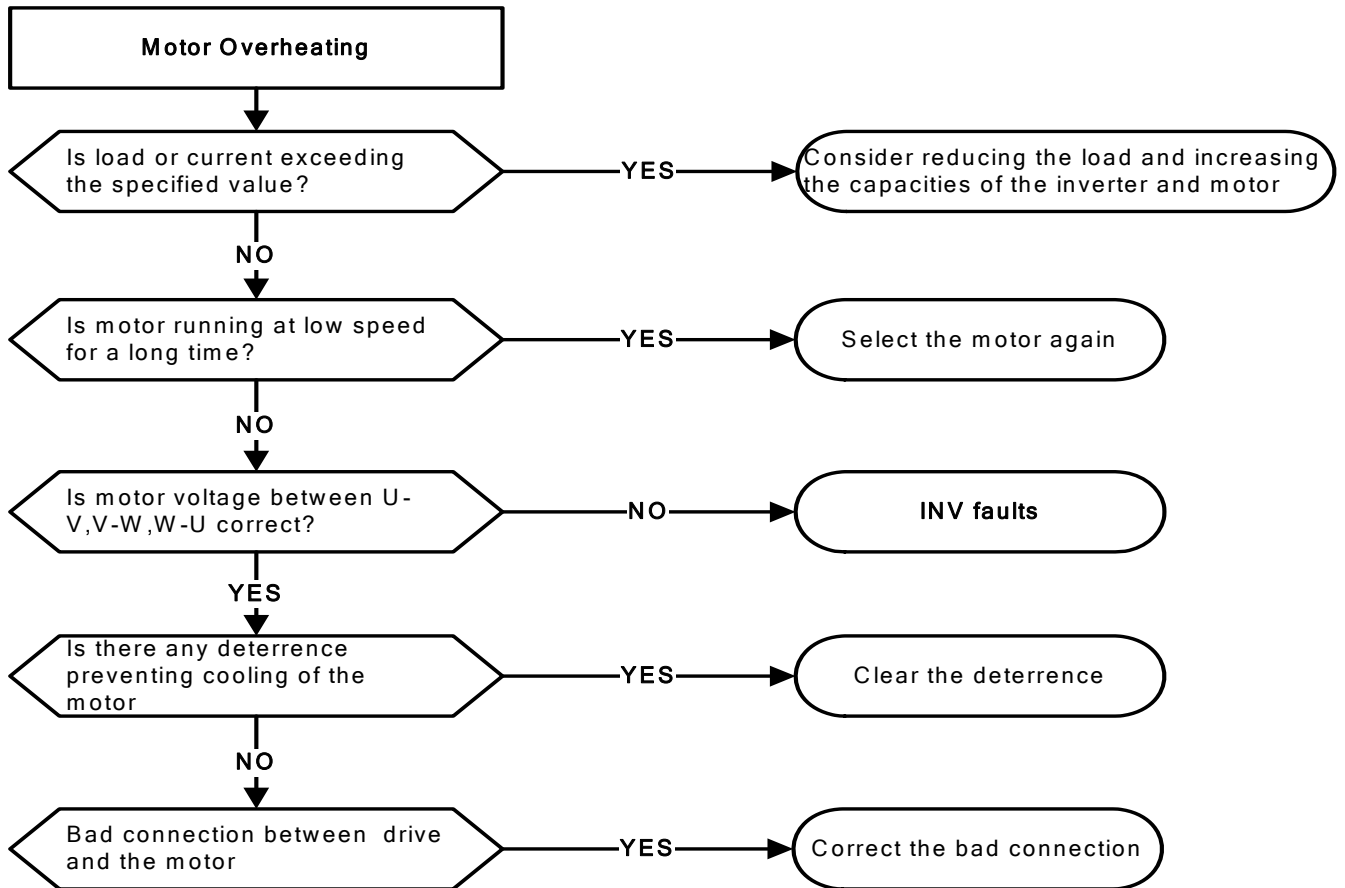

5.3.6 Motor runs unbalanced

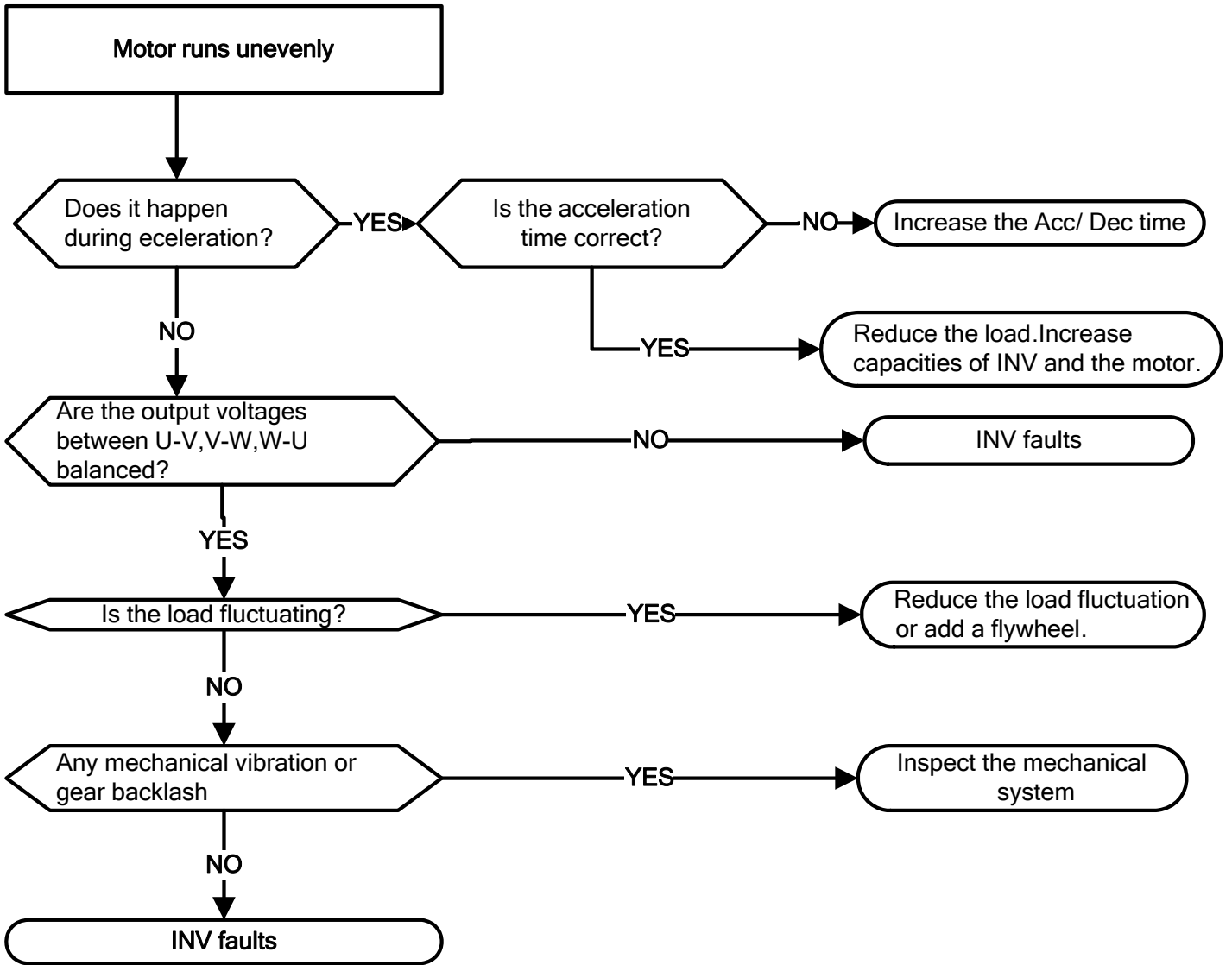

5.4 Routine and periodic inspection

To ensure stable and safe operations, check and maintain the inverter at regular intervals.

Use the checklist below to carry out inspection.

Disconnect power after approximately 5 minutes to make sure no voltage is present on the output terminals before any inspection or maintenance.

Items	Details	Checking period		Methods	Criteria	Remedies
		Daily	1Year			
Environment & Ground connection						
Ambient conditions at the installation	Confirm the temperature and humidity at the machine	◎		Measure with thermometer and hygrometer	Temperature: -10 ~40°C (14~120°F) Humidity: Below 95%RH	Improve the ambient or relocate the drive to a better area.
Installation Grounding	Is the grounding resistance correct?		◎	Measure the resistance with a multi-tester	200Vclass: below 100Ω	Improve the grounding if needed.
Terminals & Wiring						
Connection terminals	Any loose parts or terminals?		◎	Visual check Check with a screwdriver	Correct installation requirement	Secure terminals and remove rust
	Any damage to the base ?		◎			
	Any corroded Terminals?		◎			
Wiring	Any broken wires?		◎	Visual check	Correct wiring requirement	Rectify as necessary
	Any damage to the wire insulation?		◎			
voltage						
Input power voltage	Is the voltage of the main circuit correct?	◎		Measure the voltage with a multi-tester	Voltage must conform with the spec.	Improve input voltage if necessary.
Circuit boards and components						
Printed circuit board	Any contamination or damage to printed circuit board?		◎	Visual check	Correct component condition	Clean or replace the circuit board
Power component	Any dust or debris		◎			
		Check resistance between terminals		◎	Measure with a multi-tester	No short circuit or broken circuit in three phase output
Cooling System						
Cooling fan	Unusual vibration and noise?		◎	Visual and sound check	Correct cooling	Consult with the supplier
	Excessive dust or debris	◎		Visual check		Clean the fan
Heat sink	Excessive dust or debris	◎				Clean up debris or dust
Ventilation Path	Is the ventilation path blocked?	◎				

5.5 Maintenance

To ensure long-term reliability, follow the instructions below to perform regular inspection. Turn the power off and wait for a minimum of 5 minutes before inspection to avoid potential shock hazard from the charge stored in high-capacity capacitors.

Maintenance Check List.

- Ensure that temperature and humidity around the inverters is as required in the instruction manual, installed away from any sources of heat and the correct ventilation is provided..
- For replacement of a failed or damaged inverter consult with the local supplier.
- Ensure that the installation area is free from dust and any other contamination.
- Check and ensure that the ground connections are secure and correct.
- Terminal screws must be tight, especially on the power input and output of the inverter.
- Do not perform any insulation test on the control circuit.

Chapter 6 Peripherals Components

6.1 Reactor Specifications

Model: S510-□□□-XXX	Specification	
	Current (A)	Inductance (mH)(Note1)
2P5	7.2	3.05
201	11.0	2.00
202	15.5	1.42
203	21.0	1.05
401	4.2	5.25
402	5.6	3.94
403	7.3	3.02
405	12.0	1.84

Note1 : Calculated inductance based on 3% reactance

6.2 Electromagnetic Contactor and No fuse circuit breaker

Model: S510-□□□-XXX	Molded-case circuit breaker made by TECO	Magnetic contactor (MC) made by TECO
2P5	TO-50E 15A	CN-11
201/202	TO-50E 20A	
203	TO-50E 30A	
401/402/403/405	TO-50EC 15A	

6.3 Fuse Specification

Model: S510-□□□-XXX	HP	KW	Rating
2P5/201	0.5/1	0.4/0.75	15A, 300VAC
202/203	2/3	1.5/2.2	30A, 300VAC
401	1	0.75	5A, 600VAC
402	2	1.5	15A, 600VAC
403/405	3/5	2.2/3.7	20A, 600VAC

6.4 Fuse Specification(UL Model Recommended)

Model	Manufacture	Type	Rating
S510-2P5-X1(F)	Bussmann	FWC-16A10F	600V 16A
S510-201-X1(F)	Bussmann	FWC-20A10F	600V/20A
S510-202-X1(F)	Bussmann	35FE	700V 35A
S510-203-X1(F)	Bussmann	50FE	700V 50A
S510-401-X3(F)	Bussmann	FWC-10A10F	600V 10A
S510-402-X3(F)	Bussmann	FWC-16A10F	600V 16A
S510-403-X3(F)	Bussmann	FWC-20A10F	600V 20A
S510-405-X3(F)	Bussmann	25ET	690V 25A

6.5 Braking Resistor

Inverter			Catalog Number of Braking Resistor		Specification		Dimension of Braking Resistor		Braking Torque	Minimum value of Resistor	
V	HP	KW	Number of Braking Resistor	Qty	(W)	(Ω)	(LxWxH)mm	Qty	10% ED	(Ω)	(W)
220V	2	1.5	JNBR-150W100	1	150	100	251x28x60	1	119	70	210
	1Ph	3	2.2	JNBR-200W80	1	200	80	274x40x78	1	108	70
400V	1	0.75	JNBR-150W750	1	150	750	251x28x60	1	126	120	600
	2	1.5	JNBR-150W400	1	150	400	251x28x60	1	119	120	600
	3Ph	3	2.2	JNBR-260W250	1	260	250	274x40x78	1	126	100
	5	4	JNBR-400W150	1	400	150	395x40x78	1	126	60	1200

※**Note:** Braking resistor : $W = (V_{pnb} * V_{pnb}) * ED\% / R_{min}$

1. W: The power consumption of braking action
2. Vpnb: The voltage of braking action (220V=380VDC, 440V=780VDC)
3. ED%: The effective period of braking action
4. Rmin: braking resistor minimum value (ohms)

6.6 Copy Unit(JN5-CU)

The copy unit is used to copy an inverter parameter setup to another inverter. The copy unit saves time in applications with multiple inverters requiring the same parameter setup

Copy Unit (JN5-CU) dimensions

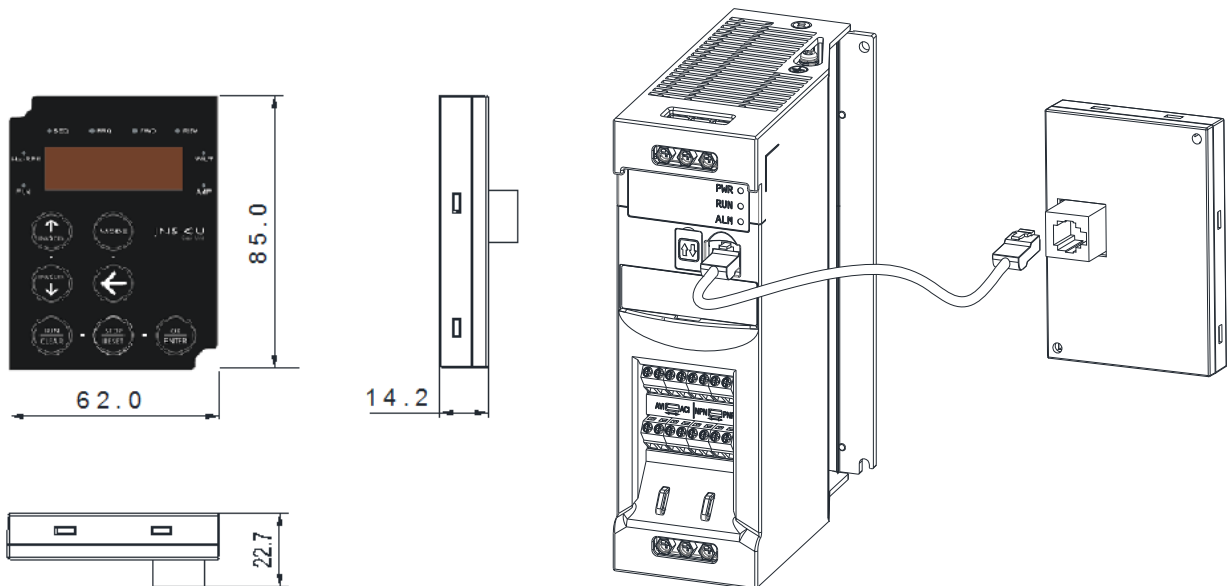

➤ Applicable Conditions of JN5-CU

Inverter	Parameter Setting of Keypad Display	Parameters of Motor	Notes
Same series Same horsepower	Can be copied	Can be copied	Parameters can be copied from old version to new version.
Same series Different horsepower	Can be copied	Can't be copied	Parameters can be copied from old version to new version.
Different series	Can't be copied	Can't be copied	-

6.7 Communication options

(a) PROFIBUS communication interface module (JN5-CM-PDP)

For wiring example and communication setup refer to JN5-CM-PDP communication option manual.

(b) DEVICENET communication interface module (JN5-CM-DNET)

For wiring example and communication setup refer to JN5-CM-DNET communication option manual.

(c) CANopen communication interface module (JN5-CM-CAN)

For wiring example and communication setup refer to JN5-CM-VAN communication option manual.

(d) TCP-IP communication interface module (JN5-CM-TCPIP)

For wiring example and communication setup refer to JN5-CM-TCPIP communication option manual.

(e) EtherNet/IP communication interface module (JN5-CM-EIP)

For wiring example and communication setup refer to JN5-CM-TCPIP communication option manual.

6.8 RJ45 to USB connecting Cable (1.8m)

JN5-CM-USB has the function of converting USB communication format to RS485 to achieve the inverter communication control being similar with PC or other control equipment with USB port.

Exterior:

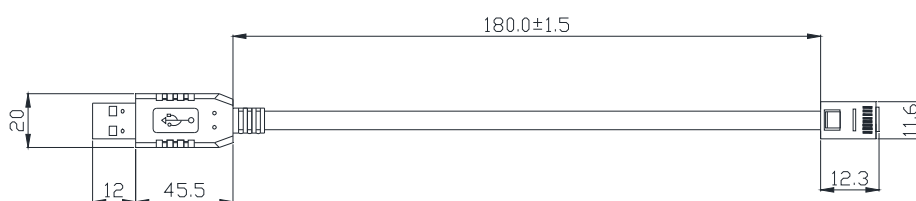

Connecting:

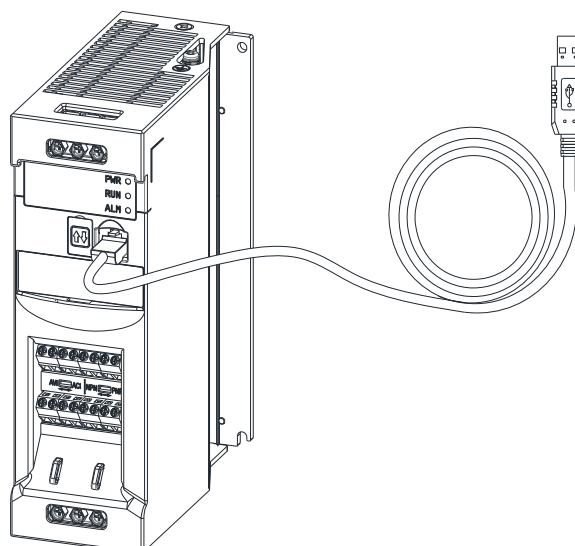

Appendix 1 S510 parameters setting list

Customer					Inverter Model		
Using Site					Contact Phone		
Address							
Parameter Code	Setting Content	Parameter Code	Setting Content	Parameter Code	Setting Content	Parameter Code	Setting Content
00-00		02-00		03-00		04-00	
00-01		02-01		03-01		04-01	
00-02		02-02		03-02		04-02	
00-03		02-03		03-03		04-03	
00-04		02-04				04-04	
00-05		02-05				04-05	
00-06		02-06		03-06			
00-07				03-07			
00-08				03-08			
00-09				03-09			
00-10							
00-11				03-11		04-11	
00-12						04-12	
00-13				03-13		04-13	
00-14				03-14		04-14	
00-15		02-15		03-15		04-15	
00-16				03-16			
00-17				03-17			
00-18				03-18			
00-19				03-19			
00-20				03-20			
01-00				03-21			
01-01							
01-02							
01-03							
01-04							
01-05							
01-06							
01-07							
01-08							
01-09							
01-10							
01-11							
01-12							
01-13							
01-14							
01-15							
01-16							
01-17							
01-18							

Parameter Code	Setting Content	Parameter Code	Setting Content	Parameter Code	Setting Content	Parameter Code	Setting Content
05-00		06-00		07-00		08-00	
05-01		06-01		07-01		08-01	
05-02		06-02		07-02		08-02	
05-03		06-03		07-03		08-03	
05-04		06-04		07-04		08-04	
05-05		06-05		07-05		08-05	
05-06		06-06		07-06		08-06	
05-07		06-07		07-07		08-07	
05-08		06-16		07-08		08-08	
05-17		06-17		07-09		08-09	
05-18		06-18		07-10		08-10	
05-19		06-19		07-11		08-11	
05-20		06-20		07-12		08-12	
05-21		06-21				08-13	
05-22		06-22				08-14	
05-23		06-23				08-15	
05-24		06-32				08-16	
05-25		06-33				08-17	
05-26		06-34				08-18	
05-27		06-35					
05-28		06-36					
05-29		06-37					
05-30		06-38					
05-31		06-39					
05-32							

Parameter Code	Setting Content	Parameter Code	Setting Content	Parameter Code	Setting Content	Parameter Code	Setting Content
09-00		10-00		11-00		12-00	
09-01		10-01		11-01		12-01	
09-02		10-02		11-02		12-02	
09-03		10-03		11-03		12-03	
09-04		10-04		11-04		12-04	
09-05		10-05		11-05		12-05	
09-06		10-06		11-06			
09-07		10-07		11-07			
09-08		10-08		11-08			
09-09		10-09		11-09			
		10-10		11-10			
		10-11		11-11			
		10-12		11-13		13-00	
		10-13		11-14		13-01	
		10-14		11-15		13-02	
		10-15		11-16		13-03	
		10-16		11-17		13-04	
		10-17				13-05	
		10-18				13-06	
		10-19				13-07	
		10-20		11-21		13-08	
		10-21				13-09	
		10-22					

Appendix-2 Instructions for UL

◆ Safety Precautions

DANGER

Electrical Shock Hazard

Do not connect or disconnect wiring while the power is on.

Failure to comply will result in death or serious injury.

WARNING

Electrical Shock Hazard

Do not operate equipment with covers removed.

Failure to comply could result in death or serious injury.

The diagrams in this section may show drives without covers or safety shields to show details. Be sure to reinstall covers or shields before operating the drives and run the drives according to the instructions described in this manual.

Always ground the motor-side grounding terminal.

Improper equipment grounding could result in death or serious injury by contacting the motor case.

Do not touch any terminals before the capacitors have fully discharged.

Failure to comply could result in death or serious injury.

Before wiring terminals, disconnect all power to the equipment. The internal capacitor remains charged even after the power supply is turned off. After shutting off the power, wait for at least the amount of time specified on the drive before touching any components.

Do not allow unqualified personnel to perform work on the drive.

Failure to comply could result in death or serious injury.

Installation, maintenance, inspection, and servicing must be performed only by authorized personnel familiar with installation, adjustment, and maintenance of AC drives.

Do not perform work on the drive while wearing loose clothing, jewelry, or lack of eye protection.

Failure to comply could result in death or serious injury.

Remove all metal objects such as watches and rings, secure loose clothing, and wear eye protection before beginning work on the drive.

Do not remove covers or touch circuit boards while the power is on.

Failure to comply could result in death or serious injury.

Fire Hazard

Tighten all terminal screws to the specified tightening torque.

Loose electrical connections could result in death or serious injury by fire due to overheating of electrical connections.

Do not use an improper voltage source.

Failure to comply could result in death or serious injury by fire.

Verify that the rated voltage of the drive matches the voltage of the incoming power supply before applying power.

Do not use improper combustible materials.

Failure to comply could result in death or serious injury by fire.

Attach the drive to metal or other noncombustible material.

NOTICE

Observe proper electrostatic discharge procedures (ESD) when handling the drive and circuit boards.

Failure to comply may result in ESD damage to the drive circuitry.

Never connect or disconnect the motor from the drive while the drive is outputting voltage.

Improper equipment sequencing could result in damage to the drive.

Do not use unshielded cable for control wiring.

Failure to comply may cause electrical interference resulting in poor system performance. Use shielded twisted-pair wires and ground the shield to the ground terminal of the drive.

NOTICE

Do not modify the drive circuitry.

Failure to comply could result in damage to the drive and will void warranty.

Teco is not responsible for any modification of the product made by the user. This product must not be modified.

Check all the wiring to ensure that all connections are correct after installing the drive and connecting any other devices.

Failure to comply could result in damage to the drive.

◆ UL Standards

The UL/cUL mark applies to products in the United States and Canada and it means that UL has performed product testing and evaluation and determined that their stringent standards for product safety have been met. For a product to receive UL certification, all components inside that product must also receive UL certification.



◆ UL Standards Compliance

This drive is tested in accordance with UL standard UL61800-5-1 and complies with UL requirements. To ensure continued compliance when using this drive in combination with other equipment, meet the following conditions:

■ **Installation Area**

Installation Environment Driver are intended for use in a pollution degree 2 environment.

■ **Main Circuit Terminal Wiring**

UL approval requires crimp terminals when wiring the drive's main circuit terminals. Use crimping tools as specified by the crimp terminal manufacturer. Teco recommends crimp terminals made by NICHIFU for the insulation cap.

The table below matches drives models with crimp terminals and insulation caps. Orders can be placed with a Teco representative or directly with the Teco sales department.

Closed-Loop Crimp Terminal Size

Drive Model	Wire Gauge		Terminal	Crimp Terminal	Tool	Insulation Cap
	mm ² , (AWG)					
S510	R/L1, S/L2, T/L3	U/T1, V/T2, W/T3	Screws	Model No.	Machine No.	Model No.
2P5	4~6(12~10)		M3.5	R2-3.5	Nichifu NH 1 / 9	TIC 2
201	4~6(12~10)				Nichifu NH 1 / 9	TIC 2
202	10		M4	R3.5-4	Nichifu NH 1 / 9	TIC 3.5
203	10		M4	R5.5-4	Nichifu NH 1 / 9	TIC 3.5
401	4~6(12~10)		M4	R3.5-4	Nichifu NH 1 / 9	TIC 2
402	4~6(12~10)				Nichifu NH 1 / 9	TIC 2
403	4~6(12~10)				Nichifu NH 1 / 9	TIC 2
405	4~6(12~10)		M4	R2-3.5	Nichifu NH 1 / 9	TIC 2

◆ Type 1

During installation, all conduit hole plugs shall be removed, and all conduit holes shall be used.

■ **Field Wiring Terminals**

All input and output field wiring terminals not located within the motor circuit shall be marked to indicate the proper connections that are to be made to each terminal and indicate that copper conductors, 75 ° C cooper wire are to be used.

■ **Drive Short-Circuit Rating**

This drive has undergone the UL short-circuit test, which certifies that during a short circuit in the power supply the current flow will not rise above value. Please see electrical ratings for maximum voltage and table below for current.

- Branch circuit protection was provided by semiconductor fuse (JFHR2/8) refer to below table for details, the drive controller and overcurrent protection device must be integrated within the same overall assembly.

Recommended Input Fuse Selection

Drive Model S510	Fuse Type	
	Manufacturer: Bussmann	
	Model	Fuse Ampere Rating (A)
200 V Class Single-Phase Drives		
2P5	Bussmann FWC-16A10F	600V 16A
201	Bussmann FWC-20A10F	600V 20A
202	Bussmann 35FE	700V 35A
203	Bussmann 50FE	700V 50A

Drive Model S510	Fuse Type	
	Manufacturer: Bussmann	
	Model	Fuse Ampere Rating (A)
400 V Class Three-Phase Drives		
401	Bussmann FWC-10A10F	600V 10A
402	Bussmann FWC-16A10F	600V 16A
403	Bussmann FWC-20A10F	600V 20A
405	Bussmann FWC-25A10F	600V 25A

- Suitable for use on a circuit capable of delivering not more than (A) RMS symmetrical amperes for (Hp) Hp in 240 / 480 V class drives motor .

Horse Power (Hp)	Current (A)	Voltage (V)
0- 50	5,000	240 / 480

◆ **Drive Motor Overload Protection**

Set parameter 02-01 (motor rated current) to the appropriate value to enable motor overload protection. The internal motor overload protection is UL listed and in accordance with the NEC and CEC.

■ **02-01 Motor Rated Current**

Setting Range: Model Dependent
 Factory Default: Model Dependent

Set 02-01 to the full load amps (FLA) stamped on the nameplate of the motor.

■ **08-05 Motor Overload Protection Selection**

The drive has an electronic overload protection function (OL1) based on time, output current, and output frequency, which protects the motor from overheating. The electronic thermal overload function is UL-recognized, so it does not require an external thermal overload relay for single motor operation.

This parameter selects the motor overload curve used according to the type of motor applied.

Overload Protection Settings

Setting	Description
XXXX0	Disabled
XXXX1	Enabled

Sets the motor overload protection function in 08-05 according to the applicable motor.

Setting 08-05 = XXXX0. Disables the motor overload protection function when two or more motors are connected to a single inverter. Use an alternative method to provide separate overload protection for each motor such as connecting a thermal overload relay to the power line of each motor.

- Motor overload protection action level is 116% of the rated current of the motor.

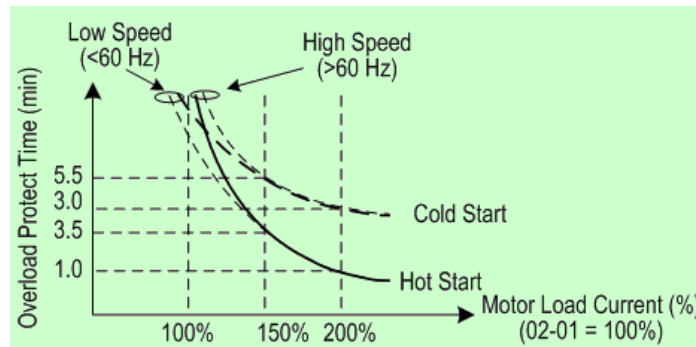

Motor Overload Protection Time

■ **08-06 Motor Overload Operation Selection**

Setting	Description
0	Free Run to Stop (default setting)
1	Alarm Only

Appendix 3 S510 Communication protocol

Modbus communication protocol

1. Communication Data Frame

S510 series inverter can be controlled by a PC or other controller with the Communication protocol, Modbus ASCII Mode & Mode RTU, RS485 or RS232. Frame length maximum 80 bytes.

1.1 Hardware installation

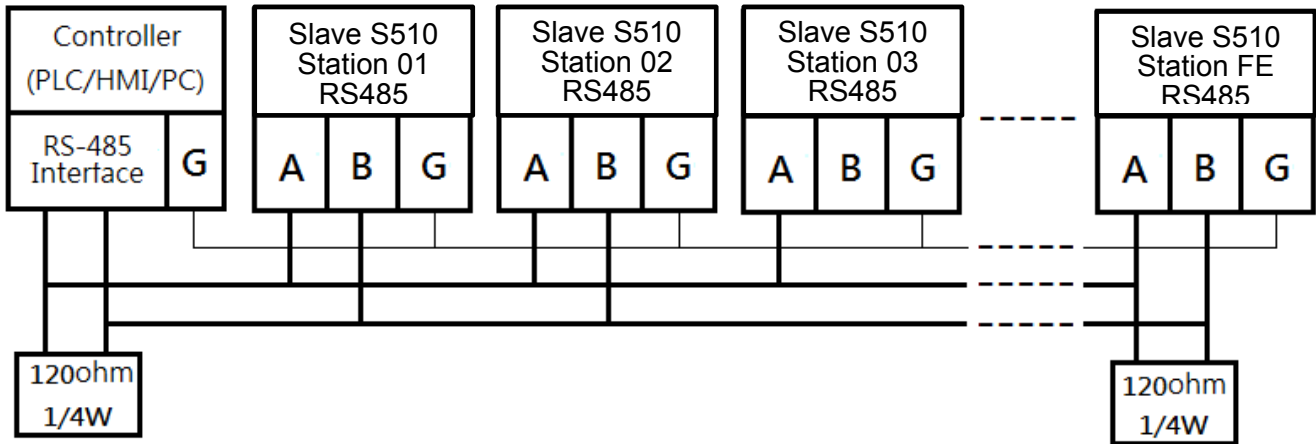

** The network is terminated at each end with an external terminating resistor (120Ω, 1/4w)**

1.2 Data format ASCII MODE

STX(3AH)	Start bit = 3AH
Address Hi	Communication Address(Station): 2-digit ASCII Code
Address Lo	
Function Hi	Function Code (command): 2-digit ASCII Code
Function Lo	
Command Start Address	Command Start byte: 4-digit ASCII Code
Command Start Address	
Command Start Address	
Command Start Address	
Data length	The length of the command: 4-digit ASCII Code
Data length	
Data length	
Data length	
LRC Check Hi	LRC Check Code: 2-digit ASCII Code
LRC Check Lo	
END Hi	End Byte : END Hi = CR(0DH) , END Lo= LF(0AH)
END L	

1.3 Data format (RTU Mode)

MASTER(PLC etc.) send request to SLAVE, whereas response to MASTER.

The signal receiving is illustrated here.

The data length is varied with the command (Function).

SLAVE Address
Function Code
DATA
CRC CHECK
Signal Interval

** The interval should be maintained at 10ms between command signal and request.

1.4 SLAVE(Address)

00H : Broadcast to all the drivers

01H : to the No.01 Drivers

0FH : to the No.15 Drivers

10H : to the No.16 Drivers

and so on....., Max to 32(20H)

1.5 Function Code

03H : Read the register contents

06H : write a WORD to register

08H : Loop test

10H : write several data to register(complex number register write)

2. CMS (Checksum and time-out definition)

2.1 LRC CHECK

```
Ex: ADDRESS          01H
     FUNCTION         03H
     COMMAND          01H
                          00H
     DATA LENGTH     0AH
```

```
Checksum = 0FH-----true complement
CS(H)    = 46H (ASCII)
CS(L)    = 31H (ASCII)
```

2.2 CRC CHECK

CRC Check Code is calculated from SLAVE Address to end of the data. The calculation method is illustrated as follow:

- (1). Load a 16-bit register with FFFF hex (all's1). Call this the CRC register.
- (2). Exclusive OR the first 8-bit byte of the message with the low-order byte of the 16-bit CRC register, putting the result in the CRC register.
- (3). Shift the CRC register one bit to the right (toward the LSB), Zero-filling the MSB, Extract and examines the LSB.
- (4). (If the LSB was 0): Repeat Steps (3) (another shift). (If the LSB was 1): Exclusive OR the CRC register with the polynomial value A001 hex (1010 0000 0000 0001), putting the result in the CRC register.
- (5). Repeat Steps (3) and (4) until 8 shifts been performed. When this is done, a complete 8-bit byte will be processed.
- (6). Repeat Steps (2) through (5) for next 8-bit byte of the message, Continue doing this until all bytes have been processed. The final content of the CRC register is the CRC value. Placing the CRC into the message: When the 16-bit CRC (2 8-bit bytes) is transmitted in the message, the Low-order byte will be transmitted first, followed by the high-order byte, For example, if the CRC value is 1241 hex, the CRC-16 Upper put the 41h, the CRC-16 Lower put the 12h.

- **CRC calculation application program**

```
UWORD ch_sum (UBYTE long, UBYTE *rxdbuff)
```

```
{
    BYTE i = 0;
    UWORD wkg = 0xFFFF;
    while ( long-- )
    {
        wkg ^= rxdbuff++;
        for ( i = 0 ; i < 8; i++ )
        {
            if ( wkg & 0x0001 )
            {
                wkg = ( wkg >> 1 ) ^ 0xa001;
            }
            else
            {
                wkg = wkg >> 1;
            }
        }
    }
    return( wkg );
}
```

3. Error code

ASCII Mode

STX	‘.’
Address	‘0’
	‘1’
Function	‘8’
	‘6’
Exception code	‘5’
	‘1’
LRC Check	‘2’
	‘8’
END	‘CR’
	‘LF’

RTU Mode

SLAVE Address		02H
Function		83H
Exception code		52H
CRC-16	High	C0H
	Low	CDH

Under communication linking, the driver responses the Exception Code and send Function Code AND 80H to main system if there is error happened.

Error Code	Description
51	Function Code Error
52	Address Error
53	Data Amount Error
54	DATA Over Range
55	Writing Mode Error

4. Inverter Control

4.1 Command Data (Readable and Writable)

Register No.	Bit	Content
2500H	Reserved	
2501H		Operation Signal
	0	Operation Command 1 : Run 0 : Stop
	1	Reverse Command 1 : Reverse 0 : Forward
	2	Abnormal 1 : EFO (Note)
	3	Fault Reset 1 : Reset
	4	Jog Forward Command 1 : Jog Forward
	5	Jog Reverse Command 1 : Jog Reverse
	6	Multi-function CommandS1 1 : "ON" 0 : "OFF"
	7	Multi-function CommandS2 1 : "ON" 0 : "OFF"
	8	Multi-function CommandS3 1 : "ON" 0 : "OFF"
	9	Multi-function CommandS4 1 : "ON" 0 : "OFF"
	A	Reserved
	B	Reserved
	C	Relay R1 1 : "ON" 0 : "OFF"
	D	Reserved
E~F	Reserved	
2502H	Frequency Command	
2503~251FH	Reserved	

*** Write in zero for Not used BIT, do not write in data for the reserved register.

Note : Bit 2 of 2501H is not for fault indication. EFO is for "external abnormality."

When there is external abnormality, controller may changes the bit value from 0 to 1 through, inverter will stop according to the setting in 07-09, inverter appears "EFO".

4.2 Monitor Data (Only for reading)

Register No.	Bit	Content
2520H	0	Operation state 1 : Run 0 : Stop
	1	Direction state 1 : Reverse 0 : Forward
	2	Inverter operation prepare state 1:ready 0 : unready
	3	Abnormal 1 : Abnormal
	4	DATA setting error 1 : Error
	5-F	Reserved

Register No.	Contents			
2521H	abnormity			
	00	The inverter is normal	25	Inverter over heat during running(OH-C)
	01	Inverter over heat(OH)	26	Stop at 0 speed(STP0)
	02	Over current at stop(OC)	27	Direct start malfunction(STP1)
	03	Under voltage(LV)	28	Control panel emergency stop(STP2)
	04	Over voltage(OV)	29	Keypad operation error)(Err1)
	05	Reserved	30	Parameter setting error(Err2)
	06	External BB(bb)	31	Analog transferred error(Err4)
	07	CPU error by external signal(CTE)	32	Parameter changed during Communication (Err5)
	08	PID feedback signal lost(PDER)	33	Communication failure(Err6) (Note)
	09	EEPROM abnormal(EPR)	34	Parameter setting error(Err7)
	10	Parameters auto measure error(ATER)	35	Restore factory setting error(Err8)
	11	Over Torque(OL3)	36	Reserved
	12	Inverter over load(OL2)	37	Reserved
	13	Motor over load(OL1)	38	Parameters copy error via copy unit (EPR1)
	14	External communication error(EFO)	39	Parameters copy incorrect via copy unit (EPR2)
	15	External stop(E.S)	40	Inverter over speed(OVSP)
	16	Parameters locked(LOC)	41	Input phase lost(PF)
	17	Reserved	42	Horsepower setting error(HPERR)
	18	Over current at constant speed (OC-C)	43	Reserved
	19	Over current during accelerating (OC-A)	44	Motor temperature overheat error(OH4)
	20	Over current during decelerating (OC-D)	45	Motor temperature overheat alarm(OH3)
	21	Over current at starting to run (OC-S)	46	Output current reaches current limit level(CL)
	22	Reserved	47	Reserved
23	Under voltage during running(LV-C)	48	Reserved	
24	Over voltage during decelerating(OV-C)	49	Reserved	

2522H	Sequence input status			
	0	Terminal S1	1 :“ON”	0:“OFF”
	1	Terminal S2	1 :“ON”	0:“OFF”
	2	Terminal S3	1 :“ON”	0:“OFF”
	3	Terminal S4	1 :“ON”	0:“OFF”
	4	Reserved		
	5	Reserved		
	Contact output			
	6	Relay R1	1 :“ON”	0:“OFF”
	7	Relay R2	1 :“ON”	0:“OFF”
9~F	Reserved			

(Note) Err6 error: Inverter gets communication error with external devices.

When inverter gets communication error:

If the controller writes “1” to “2501H bit 2”, inverter appears “EFO” on display.

If the controller does not write “1” to “2501H bit 2”, inverter appears “Err6” on display

Register No.	Content
2523H	Frequency command(100/1Hz)
2524H	Output frequency (100/1Hz)
2525H	Output voltage command (10/1V)
2526H	DC voltage command (1/1V)
2527H	Output current (10/1A)
2528H	Reserved
2529H	Output power (10/1 kW)
252AH	PID feedback (100% / fmax , 10/1%)
252BH	PID input (100% / fmax, 10/1%)
252CH	TM2 AVI input value (1000 / 10V) *1
252DH	TM2 ACI input value (1000 / 10V) *1
252EH	Reserved
252FH	A510s / L510s / E510s / S510 identification S510 standard type: 0x0110
2530H	Reserved
2531H	Inverter temperature(10/°C)(temperature of heat sink or IGBT)
2532H	The ratio of inverter and motor rated current (%)

4.3 Read the data in the holding register [03H]

Master unit reads the contents of the holding register with the continuous number for the specified quantity.

- Note:1. Limit number of read data, RTU: 37, ASCII:17.
 2. Can only Continuous read the address of the same Group
 3. Read data Quantity≥1.

(Example) Read the SLAVE station No: 01, S510 drive's frequency command.

ASCII Mode

Instruction Message		
3AH	STX	
30H	SLAVE	
31H	Address	
30H	Function	
33H	Code	
32H	Start	
35H		Address
32H		
33H		
32H	Quantity	
35H		
30H		
31H		
?		
?	LRC CHECK	
0DH	END	
0AH		

Response Message (Normal)		
3AH	STX	
30H	SLAVE	
31H	Address	
30H	Function Code	
33H		
30H	DATA Number	
32H		
31H	First holding register	
37H		
37H		
30H		
?	LRC CHECK	
?		
0DH	END	
0AH		

Response (Fault)	
3AH	STX
30H	SLAVE
31H	Address
38H	Function Code
33H	
35H	Error Code
32H	
?	LRC CHECK
?	
0DH	END
0AH	

RTU Mode

Instruction Message		
SLAVE Address		01H
Function Code		03H
Start Address	High	25H
	Low	23H
Quantity	High	00H
	Low	01H
CRC-16	High	7EH
	Low	CCH

Response Message (Normal)		
SLAVE Address		01H
Function Code		03H
DATA Number		02H
First holding register	High	07H
	Low	D0H
CRC-16	High	BBH
	Low	E8H

Response (Fault)		
SLAVE Address		01H
Function Code		83H
Error Code		52H
CRC-16	High	C0H
	Low	CDH

4.4 LOOP BACK testing [08H]

The function code checks communication between MASTER and SLAVE, the Instruction message is returned as a response message without being changed, any values can be used for test codes or data.

ASCII Mode

3AH	STX
30H	SLAVE
31H	Address
30H	Function
38H	Code
30H	Test Code
30H	
30H	
30H	
41H	DATA
35H	
33H	
37H	
31H	LRC CHECK
42H	
0DH	END
0AH	

3AH	STX
30H	SLAVE
31H	Address
30H	Function Code
38H	
30H	Test Code
30H	
30H	
30H	
41H	DATA
35H	
33H	
37H	
31H	LRC CHECK
42H	
0DH	END
0AH	

3AH	STX
30H	SLAVE
31H	Address
38H	Function
38H	Code
32H	Error Code
30H	
37H	LRC CHEC
35H	
0DH	END
0AH	

RTU Mode

SLAVE Address	01H	
Function Code	08H	
Test Code	High	00H
	Low	00H
DATA	High	A5H
	Low	37H
CRC-16	High	DAH
	Low	8DH

SLAVE Address	01H	
Function Code	08H	
Test Code	High	00H
	Low	00H
DATA	High	A5H
	Low	37H
CRC-16	High	DAH
	Low	8DH

SLAVE Address	01H	
Function Code	88H	
Error Code	20H	
CRC-16	High	47H
	Low	D8H

4.5 Write holding register [06H]

Specified data are written into the several specified holding registers from the Specified respectively.

(Example) Set SLAVE station No: 01, write S510 drive frequency reference 60.0HZ.

ASCII Mode

Instruction Message

3AH	STX
30H	SLAVE
31H	Address
30H	Function
36H	Code
32H	Start Address
35H	
30H	
32H	
31H	DATA
37H	
37H	
30H	
?	LRC CHECK
?	
0DH	END
0AH	

Response Message (Normal)

3AH	STX
30H	SLAVE
31H	Address
30H	Function Code
36H	
32H	Start Address
35H	
30H	
32H	
31H	DATA
37H	
37H	
30H	
?	LRC CHECK
?	
0DH	END
0AH	

Response (Fault)

3AH	STX
30H	SLAVE
31H	Address
38H	Function
36H	Code
35H	Error Code
32H	
?	LRC CHECK
?	
0DH	END
0AH	

RTU Mode

Instruction Message

SLAVE Address	01H	
Function Code	06H	
Start Address	High	25H
	Low	02H
DATA	High	17H
	Low	70H
CRC-16	High	2DH
	Low	12H

Response Message (Normal)

SLAVE Address	01H	
Function Code	06H	
Start Address	High	25H
	Low	02H
DATA	High	17H
	Low	70H
CRC-16	High	2DH
	Low	12H

Response (Fault)

SLAVE Address	01H	
Function Code	86H	
Error Code	52H	
CRC-16	High	C3H
	Low	9DH

4.6 Write in several holding registers [10H]

Specified data are written into the several specified holding registers from the Specified number respectively.

Note:1. Limit number of read data, RTU: 35, ASCII:15.

2. Can only Continuous read the address of the same Group.

3. Read data Quantity≥1.

(Example)Set SLAVE station No:01, S510 drive as forward run at frequency reference 60.0HZ.

ASCII Mode

Instruction Message

3AH	STX
30H	SLAVE Address
31H	
31H	Function Code
30H	
32H	Start Address
35H	
30H	
31H	
30H	Quantity
30H	
30H	
32H	
30H	
34H	DATA Number *
30H	First DATA
30H	
30H	
31H	
31H	Next DATA
37H	
37H	
30H	
?	LRC CHECK
?	
0DH	END
0AH	

Response Message (Normal)

3AH	STX
30H	SLAVE Address
31H	
31H	Function Code
30H	
32H	Start Address
35H	
30H	
31H	
30H	Quantity
30H	
30H	
32H	
?	
?	LRC CHECK
0DH	END
0AH	

Response (Fault)

3AH	STX
30H	SLAVE Address
31H	
39H	Function Code
30H	
35H	Error Code
32H	
?	LRC CHECK
?	
0DH	END
0AH	

RTU Mode

Instruction Message

SLAVE Address		01H
Function Code		10H
Start Address	High	25H
	Low	01H
Quantity	High	00H
	Low	02H
DATA Number *		04H
First DATA	High	00H
	Low	01H
Next DATA	High	17H
	Low	70H
CRC-16	High	CBH
	Low	26H

Response Message (Normal)

SLAVE Address		01H
Function Code		10H
Start Address	High	25H
	Low	01H
Quantity	High	00H
	Low	02H
CRC-16	High	1BH
	Low	04H

Response (Fault)

SLAVE Address		01H
Function Code		90H
Error Code		52H
CRC-16	High	CDH
	Low	FDH

* DATA Numbers are the actual number X 2

5. Comparison list between parameter and register

Note:

Parameter register No.: GGnnH, “GG” means Group number, “nn” means Parameter number
for example: the address of Pr 08-03 is 0803H. the address of Pr 10-11 is 0A0BH

Register No.	Function	Register No.	Function	Register No.	Function
Group00		Group01		Group02	
0000H	00-00	0100H	01-00	0200H	02-00
0001H	00-01	0101H	01-01	0201H	02-01
0002H	00-02	0102H	01-02	0202H	02-02
0003H	00-03	0103H	01-03	0203H	02-03
0004H	00-04	0104H	01-04	0204H	02-04
0005H	00-05	0105H	01-05	0205H	02-05
0006H	00-06	0106H	01-06	0206H	02-06
0007H	00-07	0107H	01-07	0207H	02-07
0008H	00-08	0108H	01-08	0208H	02-08
0009H	00-09	0109H	01-09	0209H	02-09
000AH	00-10	010AH	01-10	020AH	02-10
000BH	00-11	010BH	01-11	020BH	02-11
000CH	00-12	010CH	01-12	020CH	02-12
000DH	00-13	010DH	01-13	020DH	02-13
000EH	00-14	010EH	01-14	020EH	02-14
000FH	00-15	010FH	01-15	020FH	02-15
0010H	00-16	0110H	01-16	0210H	02-16
0011H	00-17	0111H	01-17	0211H	02-17
0012H	00-18	0112H	01-18	0212H	02-18
0013H	00-19			0213H	02-19
0014H	00-20				

Register No.	Function	Register No.	Function	Register No.	Function
Group03		Group04		Group05	
0300H	03-00	0400H	04-00	0500H	05-00
0301H	03-01	0401H	04-01	0501H	05-01
0302H	03-02	0402H	04-02	0502H	05-02
0303H	03-03	0403H	04-03	0503H	05-03
0304H	03-04	0404H	04-04	0504H	05-04
0305H	03-05	0405H	04-05	0505H	05-05
0306H	03-06	0406H	04-06	0506H	05-06
0307H	03-07	0407H	04-07	0507H	05-07
0308H	03-08	0408H	04-08	0508H	05-08
0309H	03-09	0409H	04-09	0509H	05-09
030AH	03-10	040AH	04-10	050AH	05-10
030BH	03-11	040BH	04-11	050BH	05-11
030CH	03-12	040CH	04-12	050CH	05-12
030DH	03-13	040DH	04-13	050DH	05-13
030EH	03-14	040EH	04-14	050EH	05-14
030FH	03-15	040FH	04-15	050FH	05-15
0310H	03-16			0510H	05-16
0311H	03-17			0511H	05-17
0312H	03-18			0512H	05-18
0313H	03-19			0513H	05-19
0314H	03-20			0514H	05-20
0315H	03-21			0515H	05-21
				0516H	05-22
				0517H	05-23
				0518H	05-24
				0519H	05-25
				051AH	05-26
				051BH	05-27
				051CH	05-28
				051DH	05-29
				051EH	05-30
				051FH	05-31
				0520H	05-32

Register No.	Function	Register No.	Function	Register No.	Function
Group06		Group07		Group08	
0600H	06-00	0700H	07-00	0800H	08-00
0601H	06-01	0701H	07-01	0801H	08-01
0602H	06-02	0702H	07-02	0802H	08-02
0603H	06-03	0703H	07-03	0803H	08-03
0604H	06-04	0704H	07-04	0804H	08-04
0605H	06-05	0705H	07-05	0805H	08-05
0606H	06-06	0706H	07-06	0806H	08-06
0607H	06-07	0707H	07-07	0807H	08-07
0608H	06-08	0708H	07-08	0808H	08-08
0609H	06-09	0709H	07-09	0809H	08-09
060AH	06-10			080AH	08-10
060BH	06-11			080BH	08-11
060CH	06-12			080CH	08-12
060DH	06-13			080DH	08-13
060EH	06-14			080EH	08-14
060FH	06-15			080FH	08-15
0610H	06-16			0810H	08-16
0611H	06-17				
0612H	06-18				
0613H	06-19				
0614H	06-20				
0615H	06-21				
0616H	06-22				
0617H	06-23				
0618H	06-24				
0619H	06-25				
061AH	06-26				
061BH	06-27				
061CH	06-28				
061DH	06-29				
061EH	06-30				
061FH	06-31				
0620H	06-32				
0621H	06-33				
0622H	06-34				
0623H	06-35				
0624H	06-36				
0625H	06-37				
0626H	06-38				
0627H	06-39				

Register No.	Function	Register No.	Function	Register No.	Function
Group09		Group10		Group11	
0900H	09-00	0A00H	10-00	0B00H	11-00
0901H	09-01	0A01H	10-01	0B01H	11-01
0902H	09-02	0A02H	10-02	0B02H	11-02
0903H	09-03	0A03H	10-03	0B03H	11-03
0904H	09-04	0A04H	10-04	0B04H	11-04
0905H	09-05	0A05H	10-05	0B05H	11-05
0906H	09-06	0A06H	10-06	0B06H	11-06
0907H	09-07	0A07H	10-07	0B07H	11-07
0908H	09-08	0A08H	10-08	0B08H	11-08
0909H	09-09	0A09H	10-09	0B09H	11-09
090AH	09-10	0A0AH	10-10	0B0AH	11-10
		0A0BH	10-11	0B0BH	11-11
		0A0CH	10-12	0B0CH	11-12
		0A0DH	10-13	0B0DH	11-13
		0A0EH	10-14	0B0EH	11-14
		0A0FH	10-15	0B0FH	11-15
		0A10H	10-16	0B10H	11-16
		0A11H	10-17	0B11H	11-17
		0A12H	10-18	0B12H	11-18
		0A13H	10-19	0B13H	11-19
		0A14H	10-20	0B14H	11-20
		0A15H	10-21		
		0A16H	10-22		

Appendix 4: JN5-CM-USB instruction manual

1. Model number and specification

1.1 Model number and function instruction

JN5-CM-USB is a RS232 USB type to RS485 converter. It is used for communication between PC and inverter.

1.2 Dimensions of JN5-CM-USB

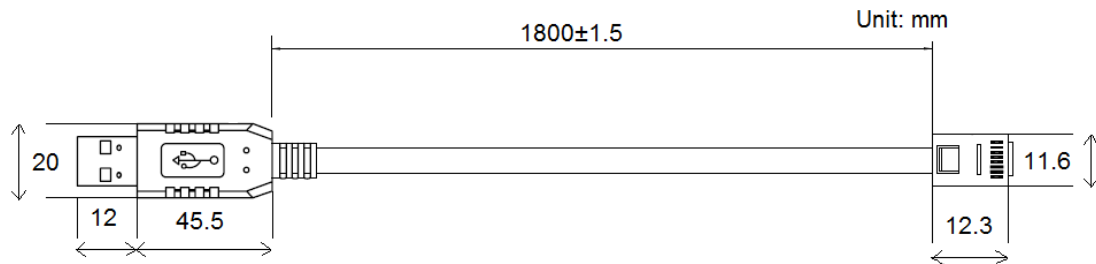

1.3 Connection between inverter and computer.

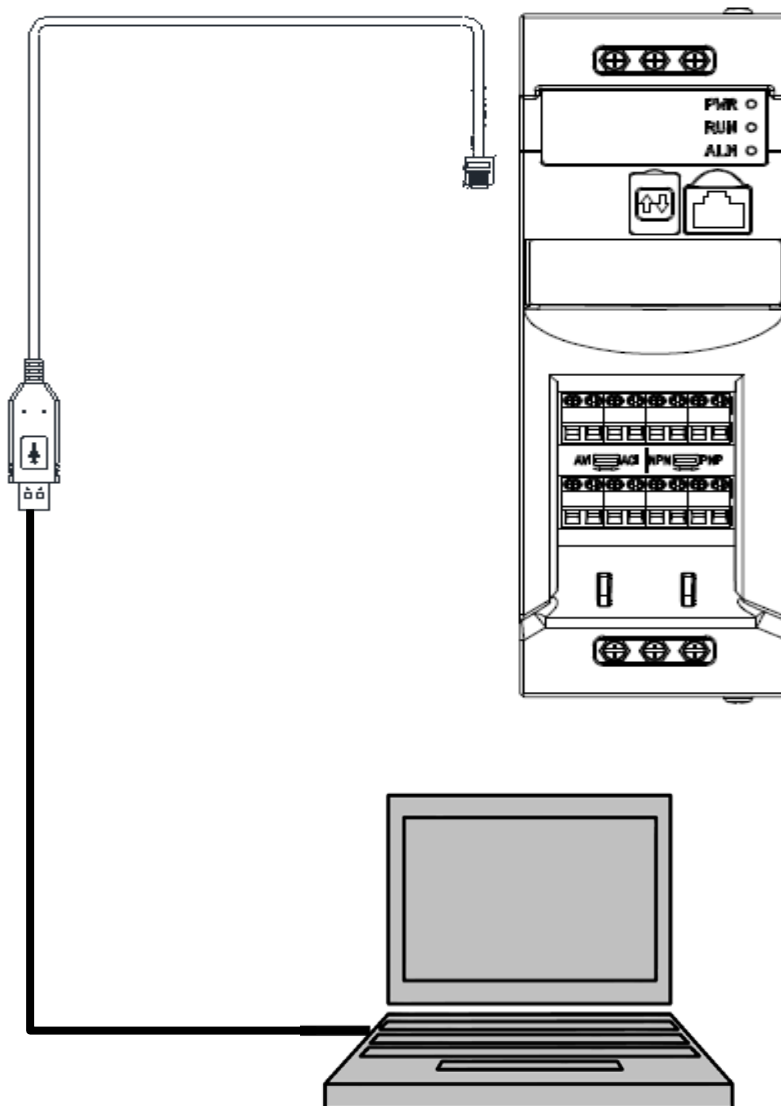

2. USB Interface Cable Pin Definition

2.1 RS232/USB at PC side.

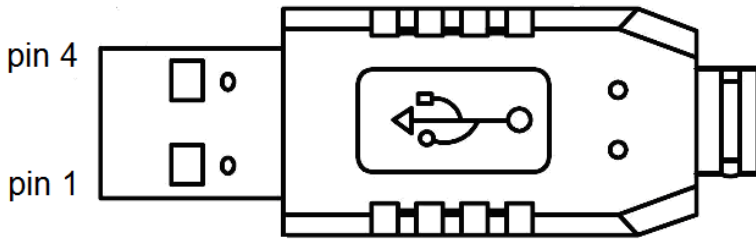

RS485/RJ45 connector at inverter side.

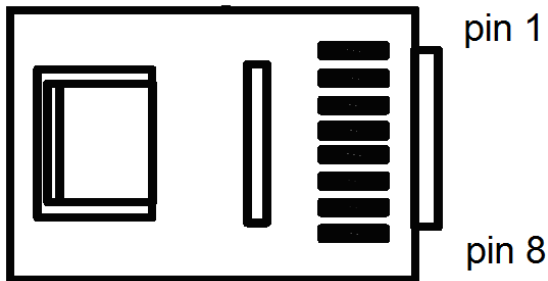

2.2 RS485/RJ45 Pin Definition.

Pin No.	Pin 1	Pin 2	Pin 3	Pin 4	Pin 5	Pin 6	Pin 7	Pin 8
Define	A	B	NC	NC	NC	NC	VCC	GND

Note:

1. A/B phase signal (Pin1&Pin2) is differential mode data signal of RS485.
2. VCC&GND is the +5Vdc power supply provided by inverter internal power source.

3. Notice

- 3-1. Please turn off the power before you connect the cable..
- 3-2. Once inverter is powered off during communication. PC software will show "communication error".
- 3-3. If there is any error during communication, please check the wiring connection and restart the pc software.

Appendix 5: S510 accessories

Accessories	Model	Function
510 Keypad extension cable (1M)	JN5-CB-01M	Keypad extension cable for 510 series
510 Keypad extension cable (2M)	JN5-CB-02M	
510 Keypad extension cable (3M)	JN5-CB-03M	
510 Keypad extension cable (5M)	JN5-CB-05M	
510 series copy module	JN5-CU	Duplicating parameters setting from one inverter to another inverter
Profibus DP communication module	JN5-CM-PDP	For connection of Profibus-DP communication protocol
TCP-IP communication module	JN5-CM-TCPIP	For connection of TCP-IP communication protocol
DeviceNet communication module	JN5-CM-DNET	For connection of DeviceNet communication protocol
CANopen communication module	JN5-CM-CAN	For connection of CANopen communication protocol
EtherNet/IP communication module	JN5-CM-EIP	For connection of EtherNet/IP communication protocol
RJ45 to USB connection cable (1.8M)	JN5-CM-USB	Using the TECO exclusive PC-software cable
Din rail (Frame 1 & 2)	JN5-DIN-S01	mounting rails to support the drive
Remote keypad	JN5-OP-S01	External LED keypad (For S510 only)



Manufacturer's Statement for S510 series

S510 efficiency according to IEC/EN 61800-9-2

Drive models: S510 series, please refer to the table below for the model list

Efficiency class: IE2

Nominal voltage: Please refer to the tabel below

Nominal frequency: 50Hz

Nominal power: Please refer to the tabel below

Motor control: V/f

Nominal current: Please refer to the table below

Nominal apparent power: Please refer to the table below

Maximum operating temperature: 40°C

CDM losses and efficiency (calculated with default settings) point: As the picture right

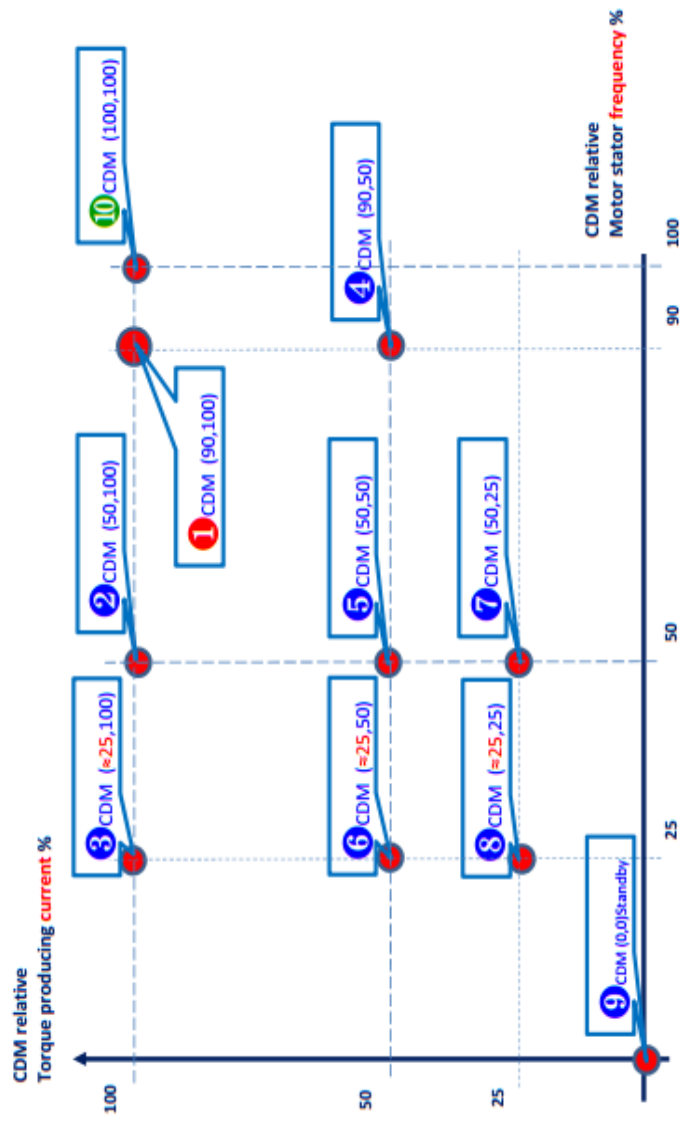

Manufacturer: TECO Electric & Machinery CO., LTD. — 10F, No.3-1, Park St., Nan-Kang, Taipei, 115603, Taiwan

EU contact: MOTOVARIO S.p.A — Via Quattro Passi 1/3 — 41043 — Formigine (MO) — ITALY. MOTOVARIO EORI number: IT02569681204

CDM losses and efficiency table

Frame	Model Name	Nominal voltage (V)	Nominal current (A)	Nominal power (kW)	Nominal apparent power (KVA)
220V Class					
1	S510-2P5-H1F	220	2.6	0.4	1
1	S510-201-H1F	220	4.3	0.75	1.65
2	S510-202-H1F	220	7.5	1.5	2.9
2	S510-203-H1F	220	10.5	2.2	4
380V Class					
1	S510-401-H3F	380	2.3	0.75	1.7
1	S510-402-H3F	380	3.8	1.5	2.9
2	S510-403-H3F	380	5.2	2.2	4
2	S510-405-H3F	380	8.8	3.7	7.01

9	8		6		6		7		5		2		4		1		10		
	p Loss(W)	η(%)	p Loss(W)	η(%)	CDM(25;50) or (*12Hz,50)	p Loss(W)	η(%)	p Loss(W)	η(%)	CDM(50,50)	p Loss(W)	η(%)	p Loss(W)	η(%)	CDM(90,50)	p Loss(W)	η(%)	CDM(100,100)	
	8	17.08	78.90	17.49	84.89	20.30	89.53	17.54	88.36	18.19	91.83	21.69	94.34	19.73	94.92	24.79	96.33	25.76	96.56
	8	19.99	81.26	23.40	87.75	31.47	90.80	20.56	89.78	24.59	93.42	34.11	94.99	27.19	95.85	40.13	96.67	42.02	96.86
	11	34.23	81.54	40.78	87.75	56.34	90.58	35.26	89.93	42.97	93.41	61.22	94.86	47.80	95.82	72.54	96.55	76.10	96.74
	11	40.10	84.07	48.50	89.40	68.55	91.71	41.70	91.36	51.94	94.26	76.35	95.39	59.80	96.25	95.05	96.77	100.99	96.90
	14	21.72	78.66	23.72	86.71	28.18	91.06	22.01	88.34	24.30	92.99	29.31	95.33	25.29	95.83	31.28	97.18	31.82	97.41
	14	27.98	82.54	31.64	88.99	39.90	92.24	28.48	90.63	32.64	94.23	41.87	95.93	34.39	96.54	45.44	97.51	46.43	97.70
	14	32.95	84.60	37.90	90.23	49.06	92.97	33.65	91.81	39.30	94.88	51.86	96.31	41.80	96.91	57.02	97.71	58.47	97.88
	17	50.08	85.95	58.70	90.98	78.17	93.35	51.33	92.56	61.21	95.27	83.23	96.49	65.80	97.12	92.92	97.79	95.70	97.95



TECO Electric & Machinery Co., Ltd.

10F., No.3-1, Yuancyu St., Nangang District,

Taipei City 115, Taiwan

Tel :+886-2-6615-9111

Fax :+886-2-6615-0933

<http://industrialproducts.teco.com.tw/>



Distributor

4KA72X776T01 Ver:01 2021.05

This manual may be modified when necessary because of improvement of the product, modification, or changes in specifications, This manual is subject to change without notice.